



Macintosh 21 Color Display





Basics

Macintosh 21-inch Color Display





Monitor Distortion

Overview

All large-screen monitors are susceptible to distortions caused by environmental conditions. These distortions are often not visible on monitors with small screens.

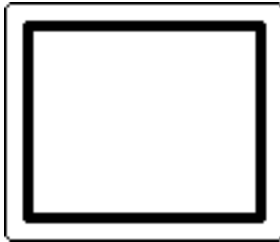

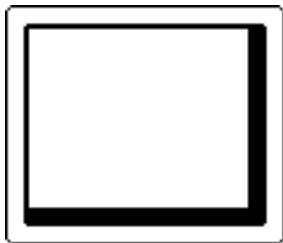

Raster Shifted Up
and Left

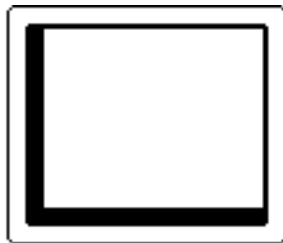

Raster Shifted Up
and Right

Important: Even monitors set to factory specifications may appear distorted when set up in a new environment.

Common environmentally caused distortions are shown on this and the following pages. Always check first for environmental causes before attempting to repair or adjust a monitor with a distorted raster.





Environmental Influences

The following environmental conditions may distort the raster of a 21-inch Color Display:

- Proximity to metal objects, such as metal desks, file cabinets, and bookshelves. Metal objects affect the earth's magnetic field. Earth magnetism usually distorts only the edges of the screen.



Right Edge Not Straight



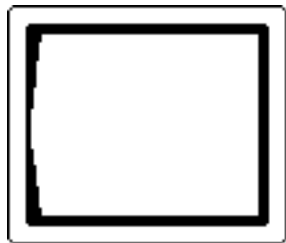

Left Side Bowed Out



Right Side Bowed In

- Fluorescent lights, other monitors, or electronic appliances such as coffee makers and copy machines. These objects cause dynamic raster distortion; that is, movement or jitter of the image.





Troubleshooting

Important: Module swapping cannot fix a monitor with environmental distortion problems, and adjusting a monitor with such problems alters the factory settings.

Note: If the monitor has shifted up/down or right/left only, adjust it using the centering controls. If you then move the monitor you may need to readjust the centering controls.

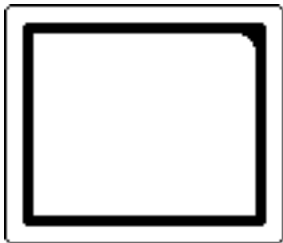

Upper-Right Corner Rounded



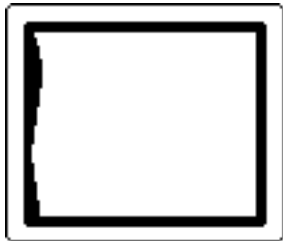

Left Edge S-Shaped



Raster Tilted Right

Before adjusting a monitor with a distorted raster,

- Swivel or move the monitor, or
- Remove the monitor from the building and recheck it in another location.

If the display changes (for better or worse) when you move it, relocate your monitor or remove the distortion-causing object.

If the display does not change, continue troubleshooting the problem.





Troubleshooting LEDs

If you encounter a “no raster” condition, check the LEDs located on the main board and the power supply board and refer to the Troubleshooting chapter for information. The flowcharts in the Troubleshooting chapter interpret LED on/off conditions and indicate which module you should replace to correct the condition.

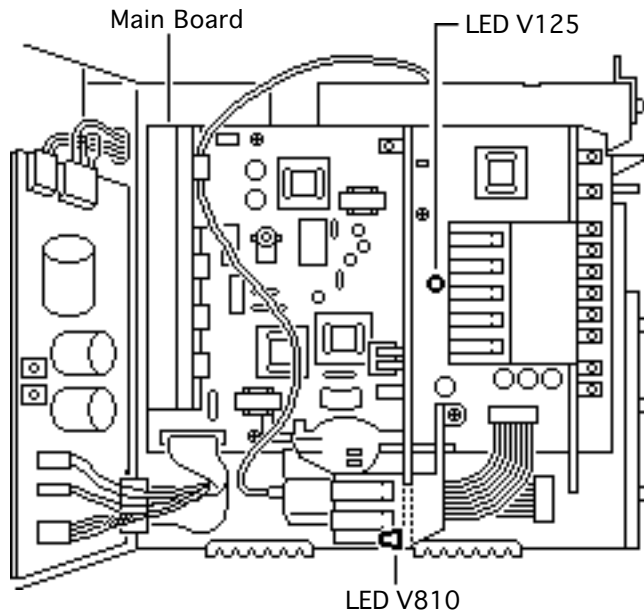



Main Board LEDs

LED V125 monitors the presence of horizontal and vertical sweeps. LED V810 monitors the presence of high voltage. The normal state of each LED is on.

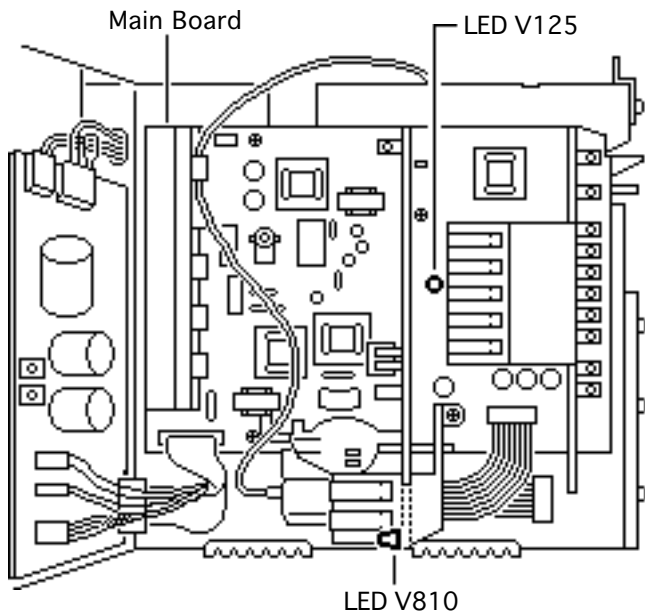



Power Supply Board LEDs

LED V683 and LED V699 monitor the power supply board. The normal state of each LED is on.

LEDs V684 and V685 monitor several conditions. The normal state of each is on (constant, not flashing).

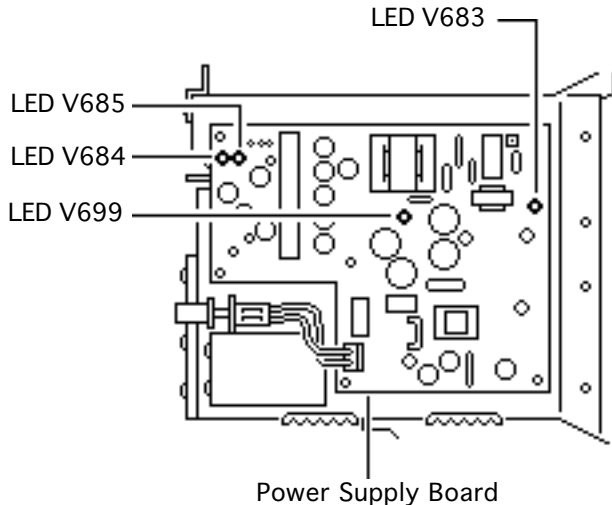



Specifications

Macintosh 21-inch Color Display





Introduction

Specifications information for this product can be found in this chapter and also in the Spec Database, which you can access in one of three ways:

- Launch it directly by double-clicking the Apple Spec Database runtime alias at the top level of the Main Service Source CD.
- Select “Apple Spec Database” from the Service Source drop-down main menu.
- Click the Acrobat toolbar icon for the database, which is near the right end of the toolbar with the letters “SP.”





Characteristics

Picture Tube

21-in. diagonal, 20-in. viewable screen
90° deflection angle; black matrix-type dot screen
Phosphor type P22 (aluminized)
Flat, square, gray filter glass (50% nominal light transmission);
anti-static coating

Screen Resolution

1152x870; 79 dpi
0.26-mm by 0.29-mm dot pitch
Displays up to 256 colors with Macintosh Display Card 8•24 or
8•24GC

Scan Rates

Vertical refresh rate: 75 Hz
Horizontal scan rate: 68.7 kHz
Rise and fall time: 5 ns maximum





**Active Video
Display Area**

14.6 in. by 11.0 in.
(371 mm by 280 mm)

Input Signals

Video: red, green, and blue analog signals; RS-343 standard





Controls and Ports

User Controls

Front panel: brightness and contrast controls

Back panel: power switch and manual degauss switch

I/O Ports

Three Apple Desktop Bus (ADB) connectors





Physical and Electrical

Power Supply

Universal power supply

Voltage: 85–135 and 170–270 VAC, self-configuring

Frequency: 47–63 Hz

Power: 165 W maximum

Size and Weight

Height: 18.5 in. (470 mm)

Width: 19.6 in. (498 mm)

Depth: 20.9 in. (530 mm)

Weight: 79.6 lb. (36.2 kg)

Monitor Stand

Built-in, tilt-and-swivel stand; automatic degaussing whenever the stand is tilted or swiveled

Three ADB ports (two ADB ports are in the front of the stand and one ADB port is at the rear of the stand)





Operating Environment

Temperature

50°F–95°F (10°C–35°C)

Humidity

95% maximum, noncondensing

Altitude

10,000 ft. (3,048 m)





Troubleshooting

Macintosh 21-inch Color Display





General

The Symptom Charts included in this chapter will help you diagnose specific symptoms related to your product. Because cures are listed on the charts in the order of most likely solution, try the first cure first. Verify whether or not the product continues to exhibit the symptom. If the symptom persists, try the next cure. (Note: If you have replaced a module, reinstall the original module before you proceed to the next cure.)

If the monitor has a “no raster” condition, refer to the “Troubleshooting LEDs” flowchart at the end of this chapter.

For additional assistance, contact Apple Technical Support.





Symptom Charts

No Raster

No raster, LED off

- 1 Check power cord connection.
- 2 Replace power cord.
- 3 Check all internal power connectors.
- 4 Troubleshoot LEDs on power supply board and main board.
Refer to “Troubleshooting LEDs” in this chapter.

No raster, LED on

- 1 Adjust contrast and brightness knobs
- 2 Verify that video card in computer is working properly.
- 3 Check connectors on main board and power supply board
- 4 Troubleshoot LEDs on power supply board and main board.
Refer to “Troubleshooting LEDs” in this chapter.





Geometry

Raster too short, tall,
narrow, or wide

- 1 Adjust V-SIZE or H-SIZE controls. See “Geometric Alignment” in this chapter.
- 2 Replace main board.

Raster not centered

- 1 Check that distortion is not due to environmental conditions. Move monitor.
- 2 Adjust H-DC SHIFT or V-SHIFT controls.
- 3 Replace main board.
- 4 Replace magnetometer degauss board.

Horizontal linearity
bad (size of text
differs at sides of
screen)

- 1 Adjust H-LIN control.
- 2 Replace main board.





Geometry (Continued)

- | | | |
|--|---|--|
| Vertical linearity bad
(size of text differs at
top vs. bottom of
screen) | 1 | Adjust V-LIN control. |
| | 2 | Replace main board. |
| Raster tilted | 1 | Check that distortion is not due to environmental conditions.
Move monitor. |
| | 2 | Perform appropriate geometry adjustments. |
| | 3 | Replace magnetometer degauss board. |
| | 4 | Replace position sensor board. |





Geometry (Continued)

Abnormal or distorted raster (corners not square, sides tilted or barrel-shaped, top of display stretched or compressed)

- 1 Check that distortion is not due to environmental conditions. Move monitor.
- 2 Check all cable connections.
- 3 Troubleshoot LEDs on power supply board and main board. Refer to “Troubleshooting LEDs” in this chapter.
- 4 Perform appropriate geometry adjustments.
- 5 Replace main board.
- 6 Replace magnetometer degauss board.





Synchronization

Picture breaks into diagonal lines

- 1 Connect a known-good monitor to computer to verify video signal.
- 2 Replace main board.

Picture rolls vertically

- 1 Verify that video card in computer is working properly.
- 2 Replace main board.
- 3 Replace video assembly.

Picture breaks and rolls horizontally

- 1 Verify that video card in computer is working properly.
- 2 Adjust H-HOLD control.
- 3 Replace main board.
- 4 Replace video assembly.

Single vertical or horizontal line on screen

- 1 Verify that CRT video board is tight on yoke connector.
- 2 Replace main board.





Geometric Alignment

Raster too tall or too short	Adjust V-SIZE (R52) control until height is 280 mm (± 3 mm).
Raster too wide or too narrow	Adjust H-SIZE (R93) control until width is 371 mm (± 3 mm).
Raster shifted left or right	Adjust H-PHASE (R262) and H-DC SHIFT (R117) controls.
Raster shifted up or down	Adjust V-SHIFT (R75) control.
Rectangles at left smaller/larger than rectangles at right	Adjust H-LIN (R101) control.





Geometric Alignment (Continued)

Rectangles at top
smaller/larger than
rectangles at bottom

Adjust V-LIN (R26) control.

Raster not straight at
top or bottom

Adjust N/S PHASE (R262) and N/S TRAP (R69) controls, and
adjust N/S (R34) and N/S BAL (R28) controls.

Center line not
horizontal

Adjust N/S TILT (R74) control.

Center line not
straight

Adjust N/S BAL (R28) control.

Raster not straight at
left or right

Adjust E/W AMP (R89) control.





Geometric Alignment (Continued)

Raster not vertical at
left or right

Adjust E/W TRAP (R80) control.





Convergence Alignment

Red and blue visible in vertical lines	Adjust H-STATIC control on magnetometer degauss board.
Red and blue visible in horizontal lines	Adjust V-STATIC control on magnetometer degauss board.
Red and blue visible in top 2 inches (50 mm) of vertical lines	Adjust VR3 yoke control.
Red and blue visible in top 1/4 inch (5 mm) of vertical lines	Adjust VR2 yoke control.





Convergence Alignment (Continued)

Red and blue visible
in top 4 inches (100
mm) of vertical lines

Adjust VR5 yoke control.

Red and blue visible
in top 2 inches (50
mm) of leftmost and
rightmost vertical
lines

1 Adjust AMP-T yoke control.

Note: If AMP-T doesn't correct problem, you may need to use TILT-T and AMP-T controls interactively.

2 Adjust TILT-T yoke control.

Note: TILT-T affects lines at top-left side of screen more than lines at top-right side of screen.

Red and blue visible
in bottom 2 inches
(50 mm) of vertical
lines

Adjust VR4 yoke control.





Convergence Alignment (Continued)

Red and blue visible
in bottom 4 inches
(100 mm) of vertical
lines

Adjust VR6 yoke control.

Red and blue visible
in bottom 2 inches
(50 mm) of leftmost
and rightmost
vertical lines

1 Adjust AMP-B yoke control.

Note: If AMP-B doesn't correct problem, you may need to use TILT-B and AMP-B controls interactively.

2 Adjust TILT-B yoke control.

Note: TILT-B affects lines at bottom-left side of screen more than lines at bottom-right side of screen.





Convergence Alignment (Continued)

Red and blue visible
in vertical lines at
left and right edges of
screen

1 Adjust H-RIGHT yoke control.

Note: If H-RIGHT doesn't correct problem, you may need to use H-LEFT1 and H-RIGHT controls interactively.

2 Adjust H-LEFT1 yoke control.

Note: H-LEFT1 affects vertical lines at left edge of screen more than vertical lines at right edge of screen.

Red and blue visible
in vertical lines 3-5
inches (75-125
mm) from left and
right edges of screen

Adjust H-LEFT2 yoke control.





Convergence Alignment (Continued)

Red and blue visible
in vertical lines on
left third of screen

Adjust 1/2W yoke control.

Red and blue visible
in horizontal lines at
top and bottom edges
of screen

1 Adjust V-NS yoke control.

Note: If V-NS doesn't correct problem, you may need to use V-NS and V-N controls interactively.

2 Adjust V-N yoke control.

Red and blue are
visible in centermost
horizontal lines at
left and right edges of
screen

Adjust V-EW yoke control.





Convergence Alignment (Continued)

Red and blue visible at
left edge of center
horizontal line

Adjust V-W yoke control.





Video

Predominant red, blue, or green tint

- 1 Verify that video card in computer is working properly.
- 2 Perform video adjustments.
- 3 Replace video assembly.
- 4 Replace video filter boards.
- 5 International only: Replace CRT. Domestic only: Call Apple Technical Support to confirm a CRT failure.

Picture too dark or too bright

- 1 Adjust contrast and brightness knobs.
- 2 Verify that video card in computer is working properly.
- 3 Perform video adjustments.
- 4 Replace power supply board.
- 5 Replace video assembly.
- 6 Replace video filter boards.
- 7 International only: Replace CRT. Domestic only: Call Apple Technical Support to confirm a CRT failure.





Video (Continued)

Out of focus

- 1 Adjust focus controls.
- 2 Replace flyback transformer assembly.
- 3 Replace main board.
- 4 International only: Replace CRT. Domestic only: Call Apple Technical Support to confirm a CRT failure.

Out of convergence (color bleeding out from text or lines)

- 1 Verify that video card in computer is working properly.
- 2 Check Convergence Alignment symptom chart and perform appropriate adjustment.
- 3 Perform convergence adjustments.
- 4 International only: Replace CRT. Domestic only: Call Apple Technical Support to confirm a CRT failure.





Miscellaneous

Intermittently shuts down	<ol style="list-style-type: none">1 Replace flyback transformer assembly.2 Replace main board.
Picture jitters or flashes	<ol style="list-style-type: none">1 Check all ground cable connections.2 Verify that adjacent computer equipment is properly grounded.3 Move electrical devices away from monitor and shut off fluorescent lights.4 Replace main board.
At a resolution of 1152x870, jitter or a wavy image appears on right side, left side, or entire screen	<p>Note: This symptom occurs with Power Macintosh 9600 computers using an Apple/IMS video card with any display set at 1152x870 screen resolution. The computer and the display are working properly. However, video cards with serial numbers lower than Fx705xxx should be replaced. Apple's service stock has been inspected and upgraded, so replacement video boards should not exhibit this symptom.</p> <p>Check the serial number on the video card. If it is lower than Fx705xxx, replace the video card with a new one (Apple service part number 661-1409).</p>
Screen has black spots (burnt phosphors)	International only: Replace CRT. Domestic only: Call Apple Technical Support to confirm a CRT failure.
Monitor emits high-pitched noise	Replace flyback transformer assembly.
Does not degauss	<ol style="list-style-type: none">1 Replace magnetometer degauss board.2 Replace position sensor board.
No communication or erratic communication with ADB device	<ol style="list-style-type: none">1 Replace keyboard, mouse, or other ADB device.2 Replace ADB cable in monitor stand.





Troubleshooting LEDs

Use this flowchart only if the monitor has a "no raster" condition.

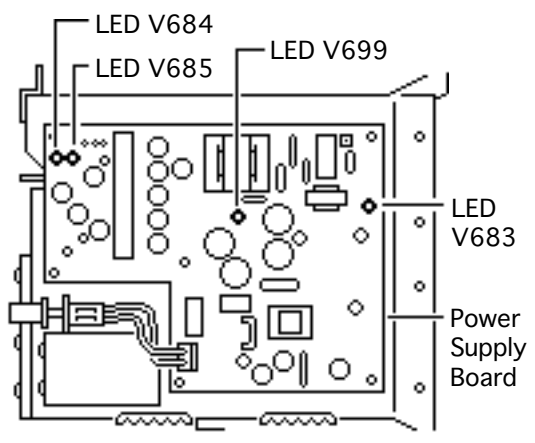
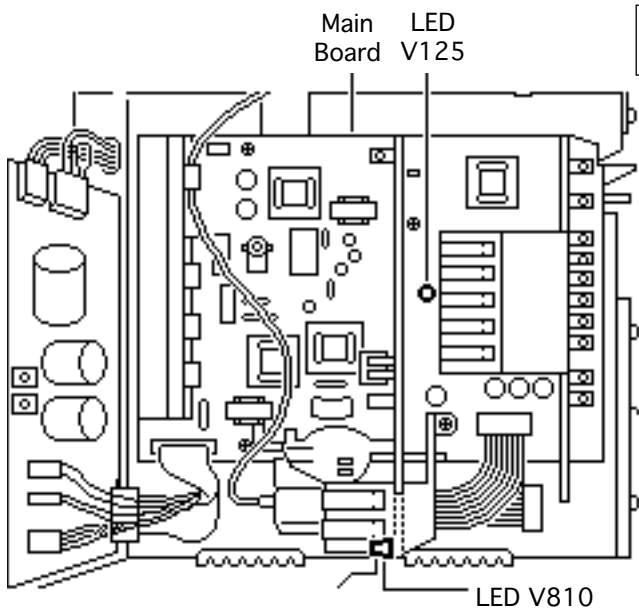
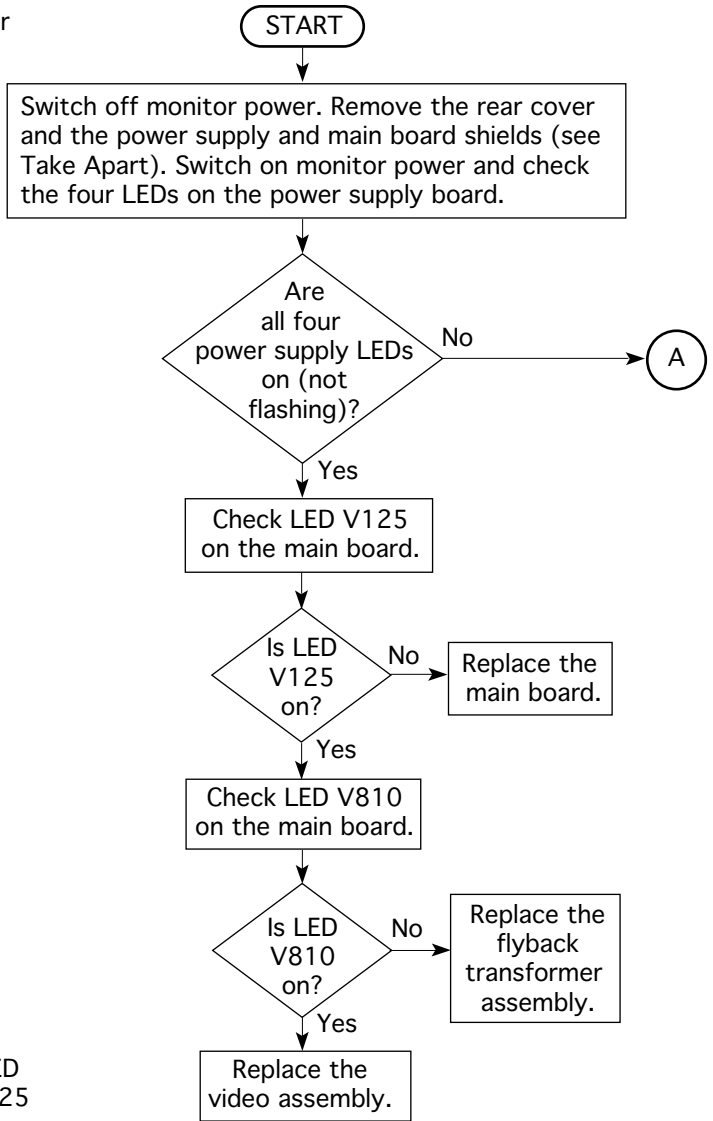

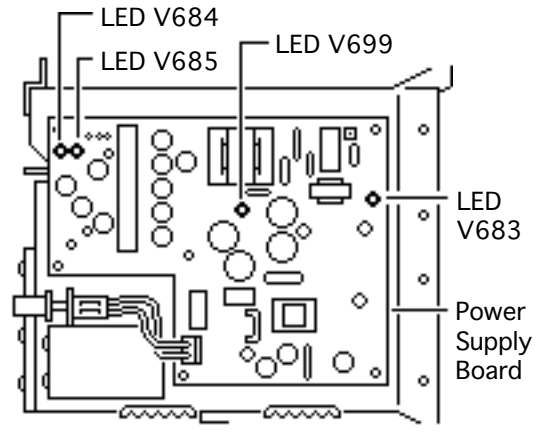
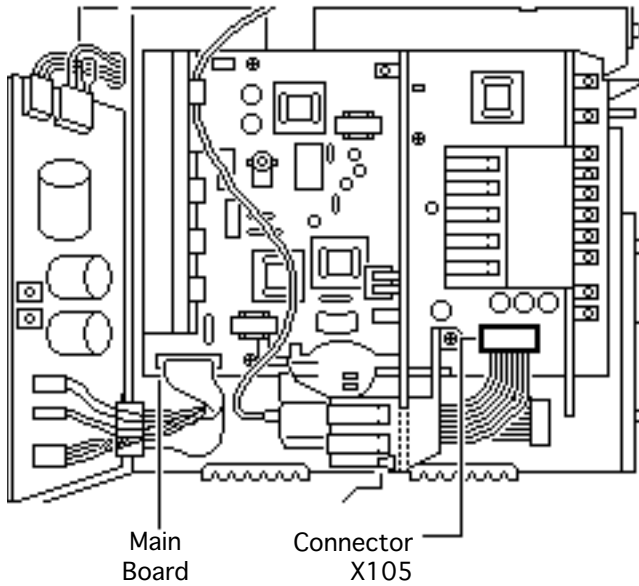
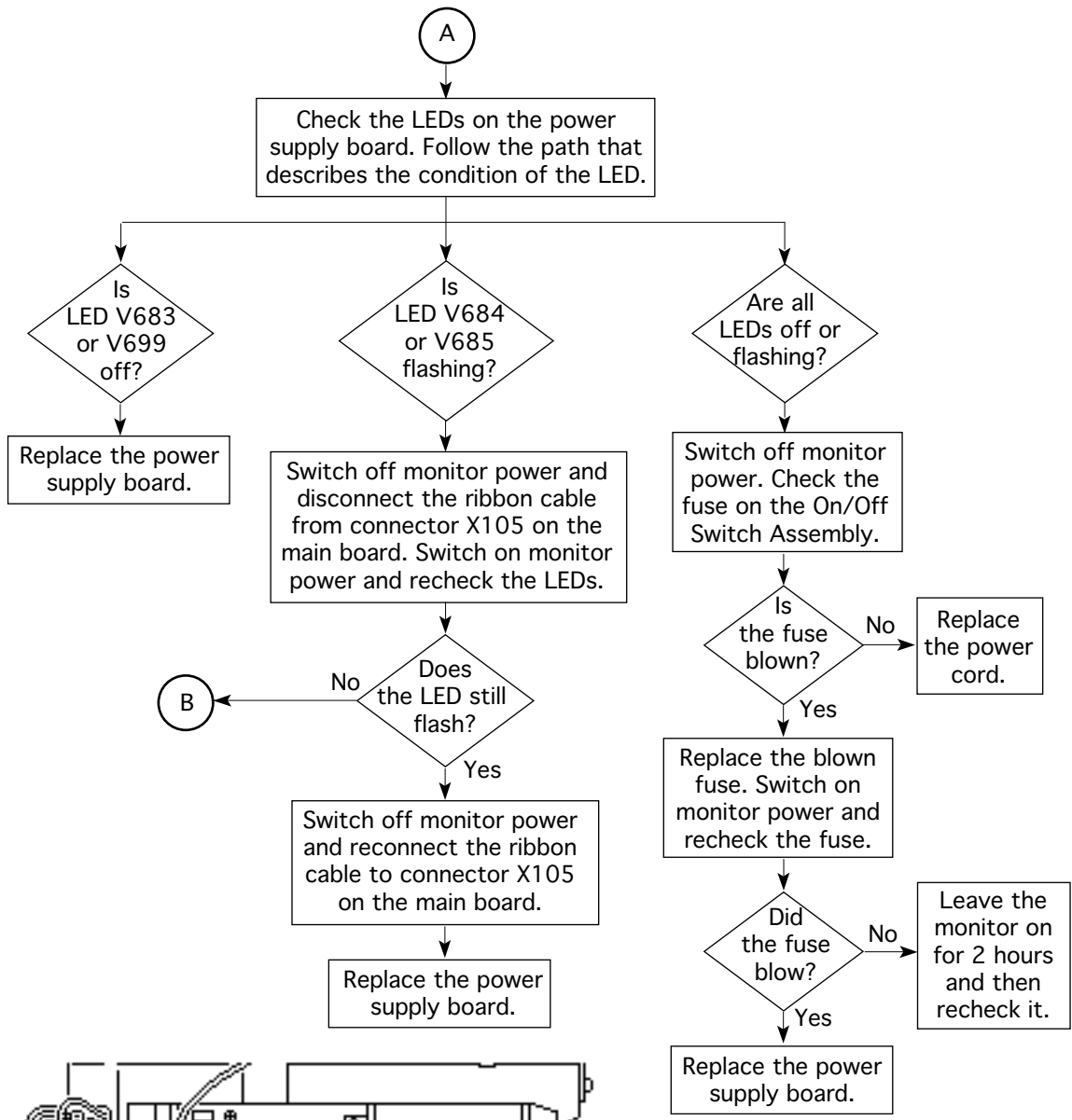

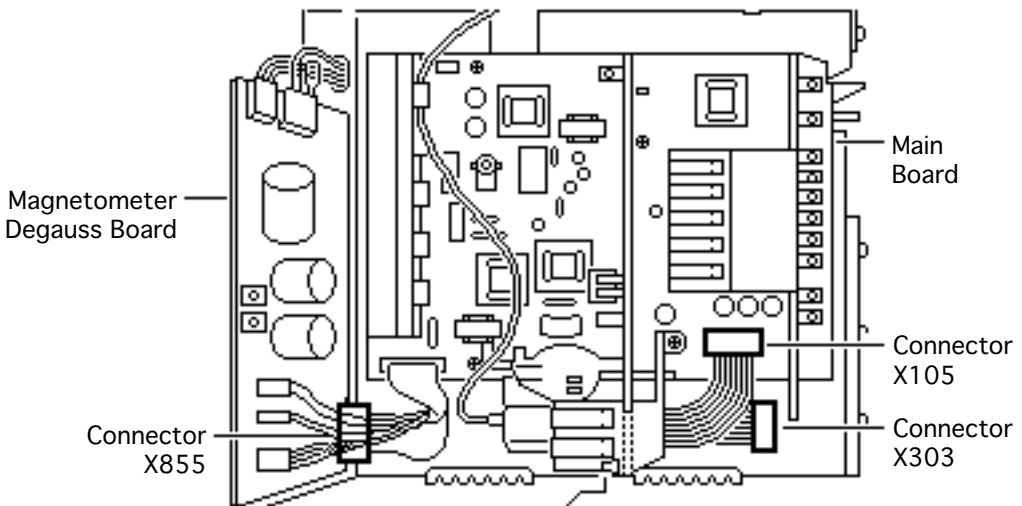
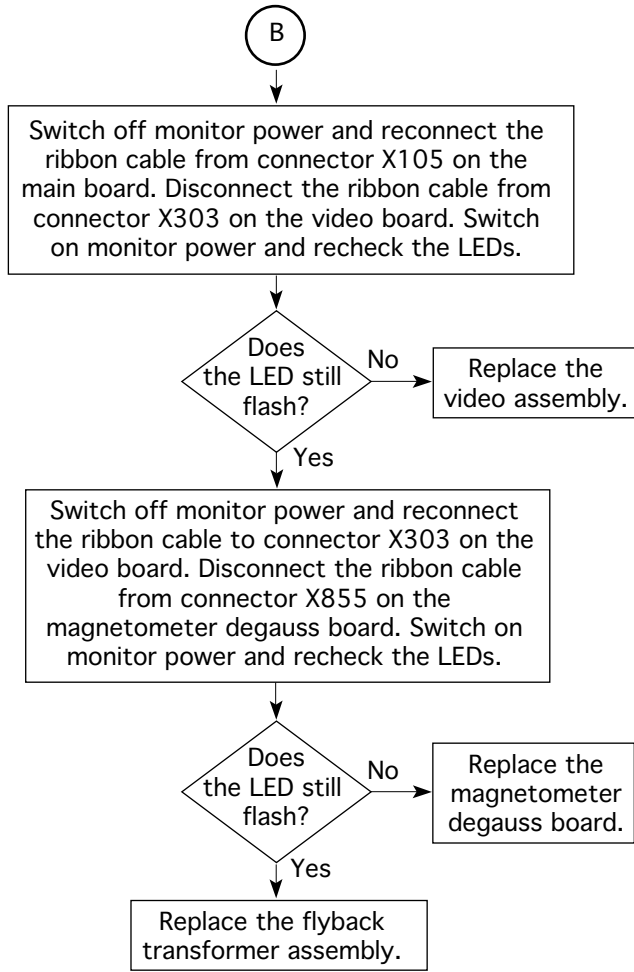



Take Apart

Macintosh 21-inch Color Display



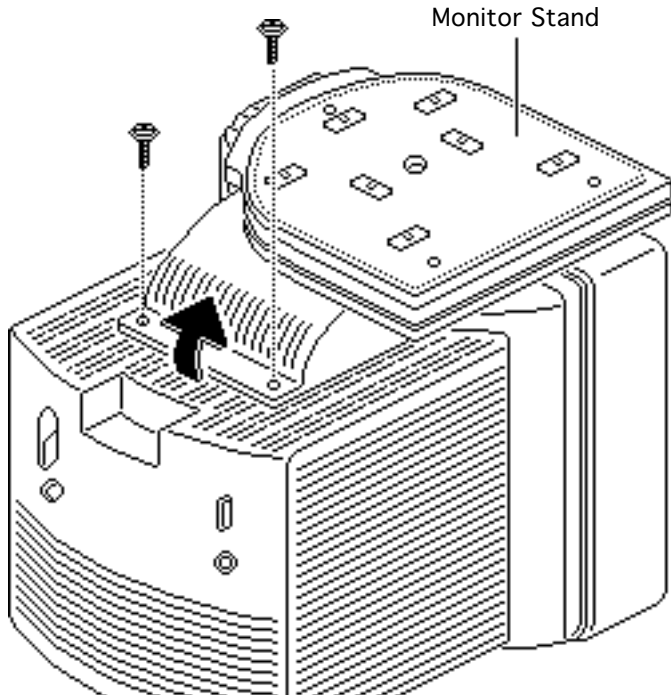

Monitor Stand

Before you begin,

- Turn off the monitor power
- Disconnect cables from the monitor

- 1 With the monitor upside down on a protective pad, swivel the base of the stand aside and remove the two mounting screws.
- 2 Lift the rear of the stand and remove it from the bezel.



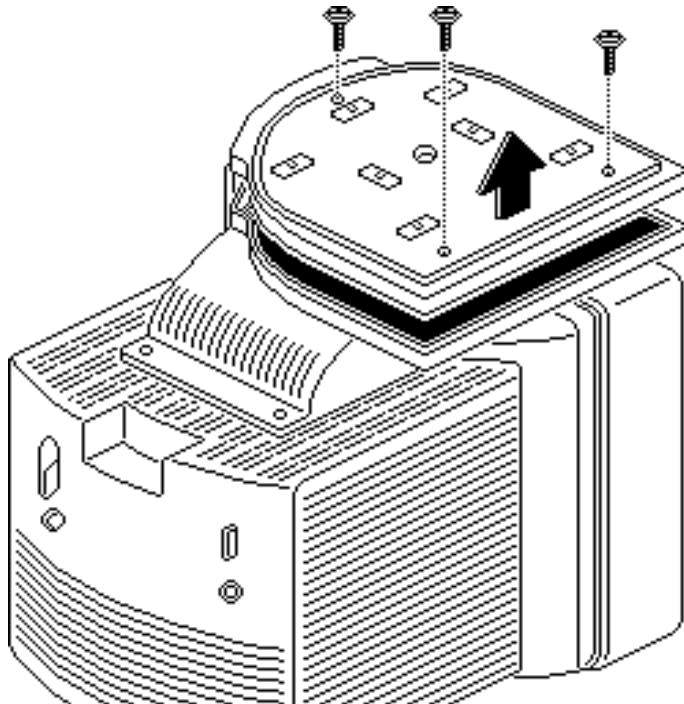

Internal ADB Cable

Before you begin,

- Turn off the monitor power
- Disconnect cables from the monitor

- 1 With the monitor upside down on a protective pad, remove the three screws that secure the cover to the base of the monitor stand.
- 2 Separate the cover from the base.



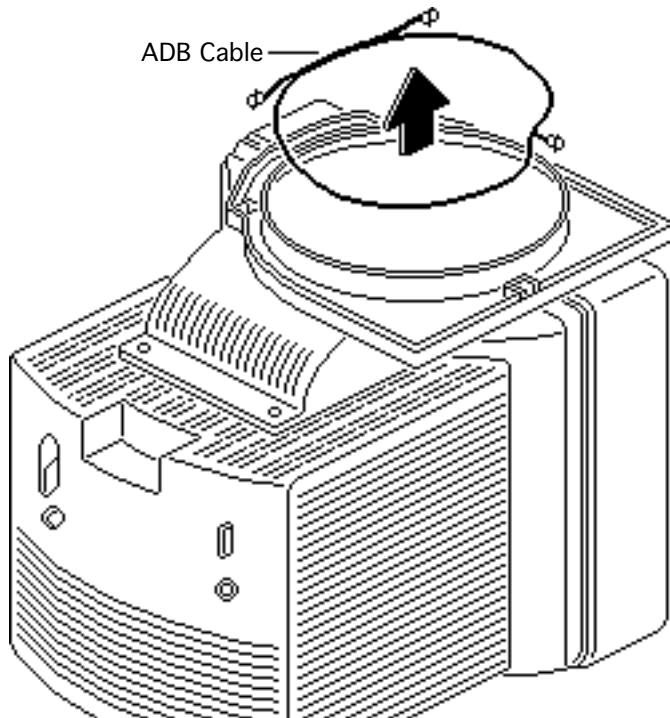

- 3 Remove the three ADB cable connectors from the base of the monitor stand.

Note: If necessary, use an art knife to cut the sealant on the connectors.



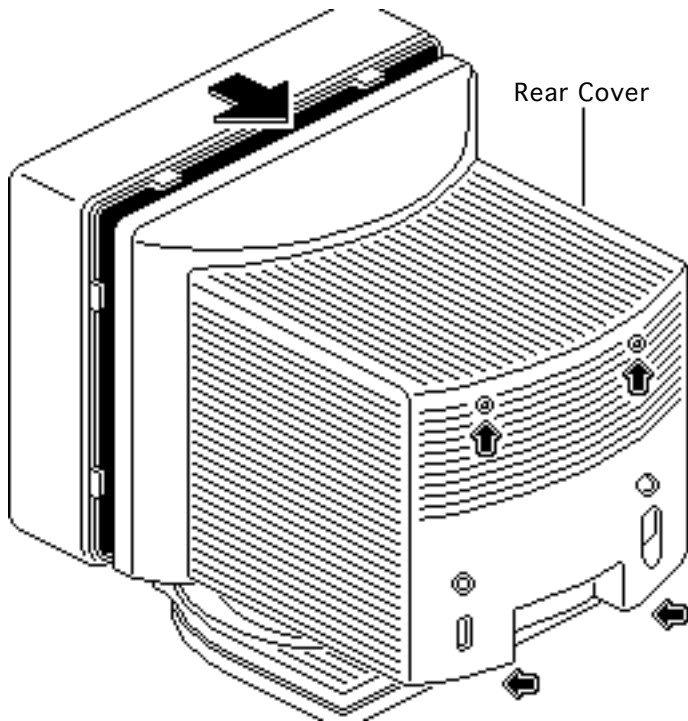

Rear Cover

Before you begin,

- Turn off the monitor power
- Disconnect cables from the monitor

⚠ Warning: This product contains high voltage and a high-vacuum picture tube. To prevent serious injury, review CRT safety in Bulletins/Safety.

Loosen the four captive case screws and pull the rear cover off the bezel.



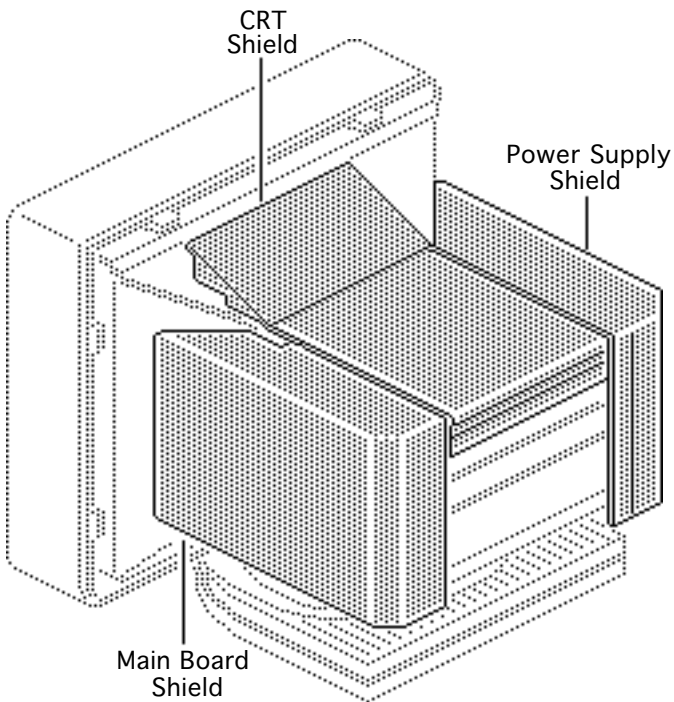

EMI Shields

Before you begin, remove the rear cover.

⚠ Warning: This product contains high voltage and a high-vacuum picture tube. To prevent serious injury, review CRT safety in Bulletins/Safety.

Note: The Macintosh 21 Inch Color Display contains three EMI shields. You will need to remove one or more of the shields to access the replaceable modules.





Main Board Shield

- 1 Loosen (but don't remove) the five screws that secure the main board shield to the chassis.
- 2 Swing the shield open and lift it off the chassis.

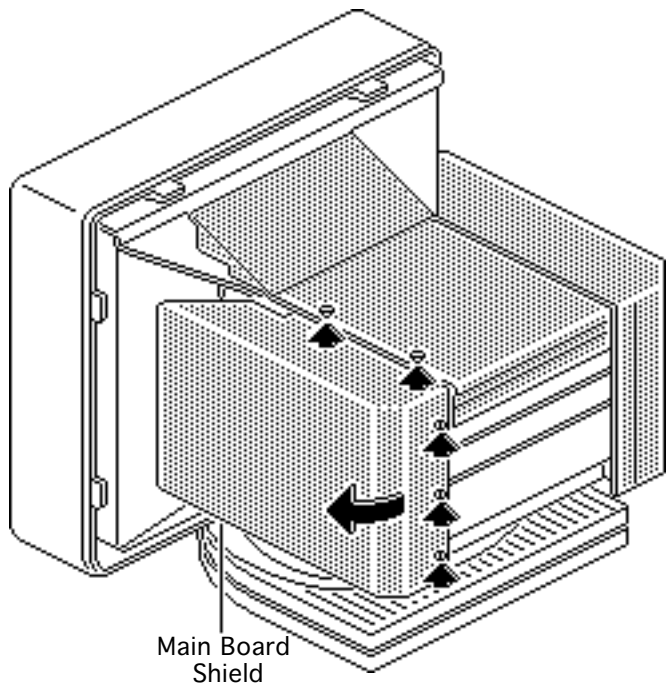

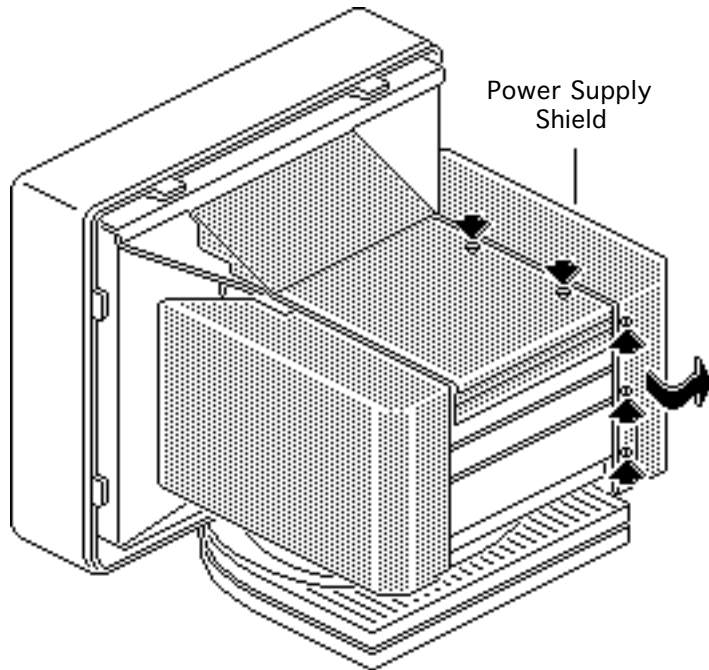

Power Supply Shield

- 1 Loosen (but don't remove) the five screws that secure the power supply shield to the chassis.
- 2 Swing the shield open and lift it off the chassis.





CRT Shield

- 1 Loosen (but don't remove) the five screws that secure the CRT shield to the chassis.
- 2 Pull back the shield and lift it off the chassis.

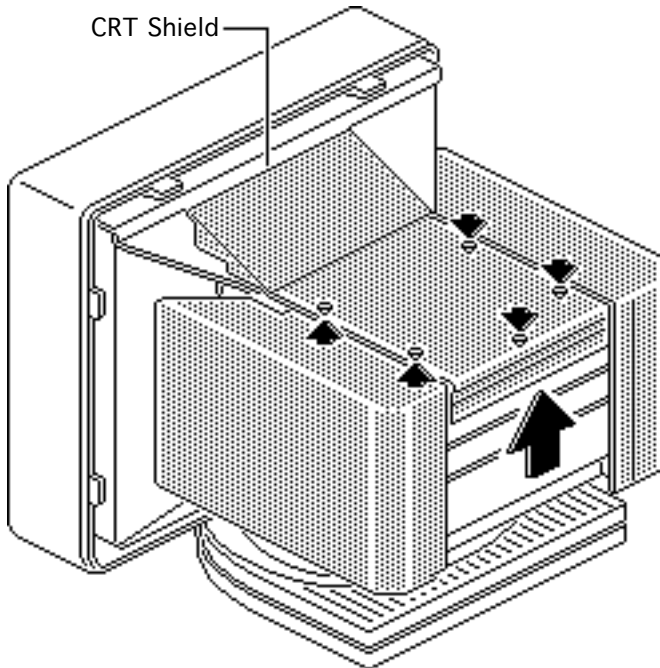

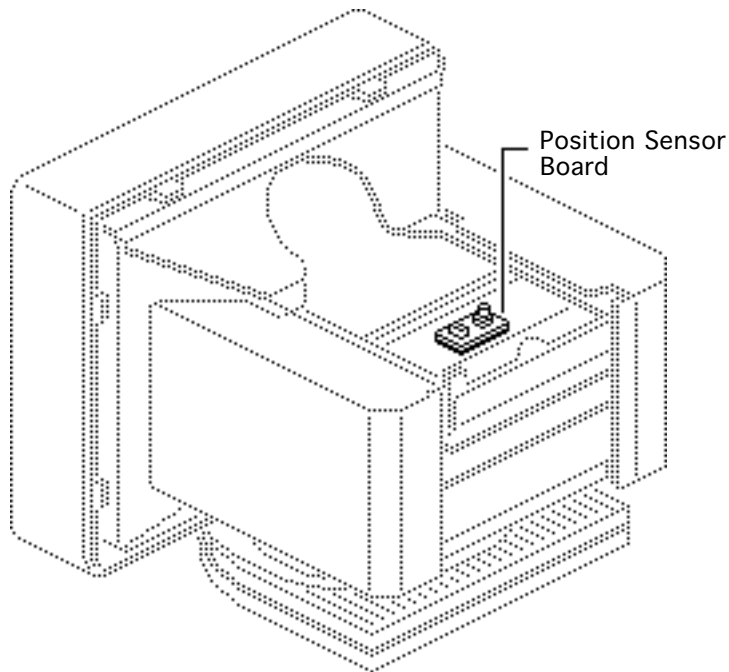

Position Sensor Board

Before you begin,

- Remove the rear cover
- Remove the CRT shield
- Discharge the CRT

⚠ Warning: This product contains high voltage and a high-vacuum picture tube. To prevent serious injury, review CRT safety in Bulletins/Safety.

⚠ Warning: Never use a grounding wriststrap until after discharging the CRT.



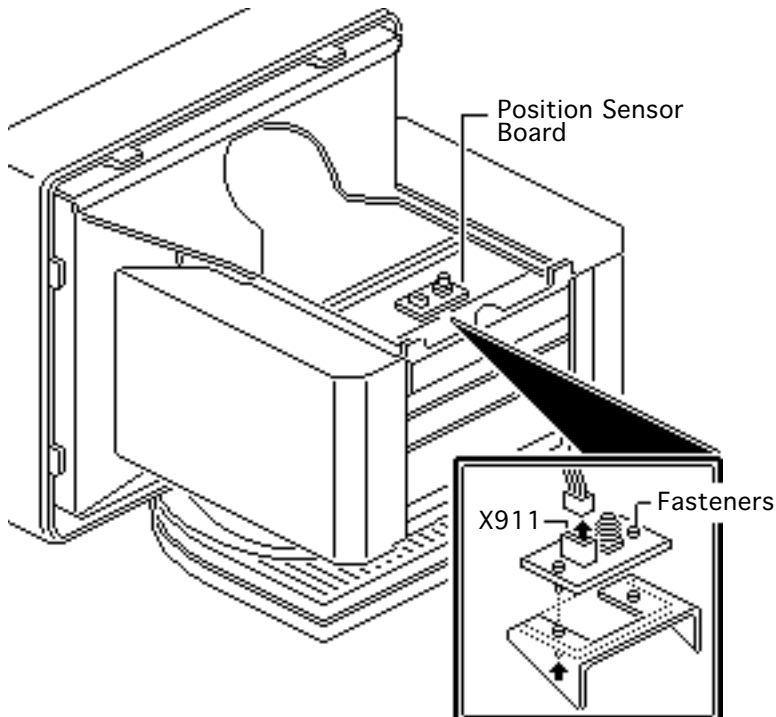

- 1 Disconnect the 6-wire cable from connector X911 on the position sensor board.
- 2 **Note:** To pry out the fasteners, you may need to reach beneath the position sensor board and pop up the fasteners with your fingers.

Using a jeweler's screwdriver, pry out the two fasteners and remove the position sensor board.



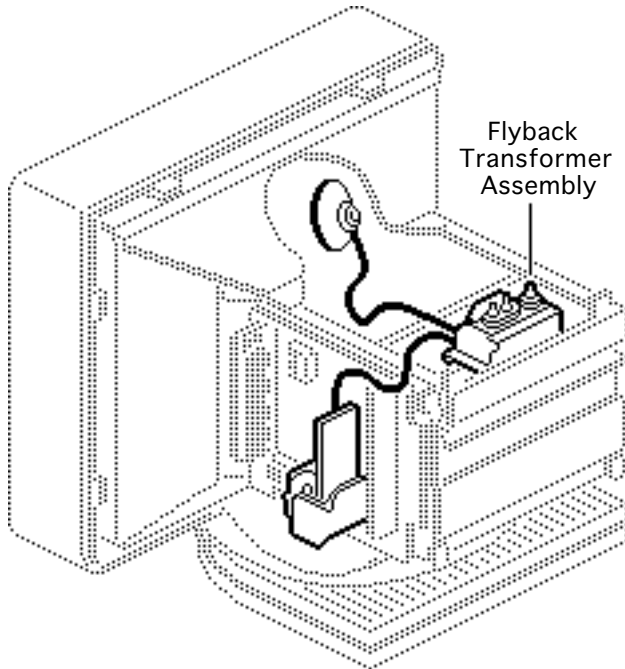

Flyback Transformer Assembly

Before you begin,

- Remove the rear cover
- Remove the main board and CRT shields
- Discharge the CRT
- Remove the anode cap

⚠ Warning: This product contains high voltage and a high-vacuum picture tube. To prevent serious injury, review CRT safety in Bulletins/Safety.





⚠ Warning: Never use a grounding wriststrap until after discharging the CRT.

Note: The flyback transformer assembly includes the flyback transformer, the high-voltage block, and the anode connector and wire. To access other modules, you may need to remove only the high-voltage block or the flyback.



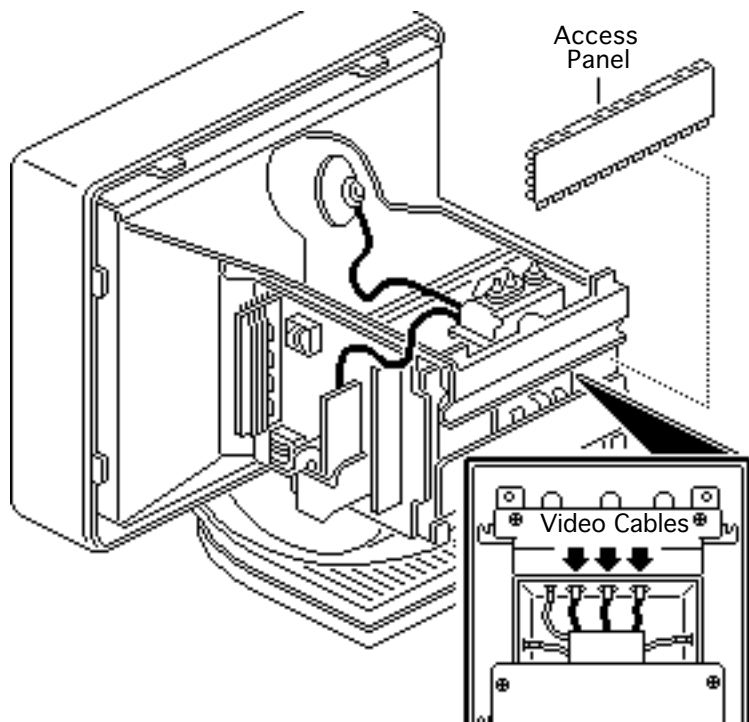

High-Voltage Block

- 1 Pull the CRT/video board access panel off the rear of the chassis.
- 2 Disconnect the three video cables from the bottom of the high-voltage block.

Replacement Caution: The three video cables are not interchangeable. Be sure to connect these color-coded cables to the terminals labeled with the same color.



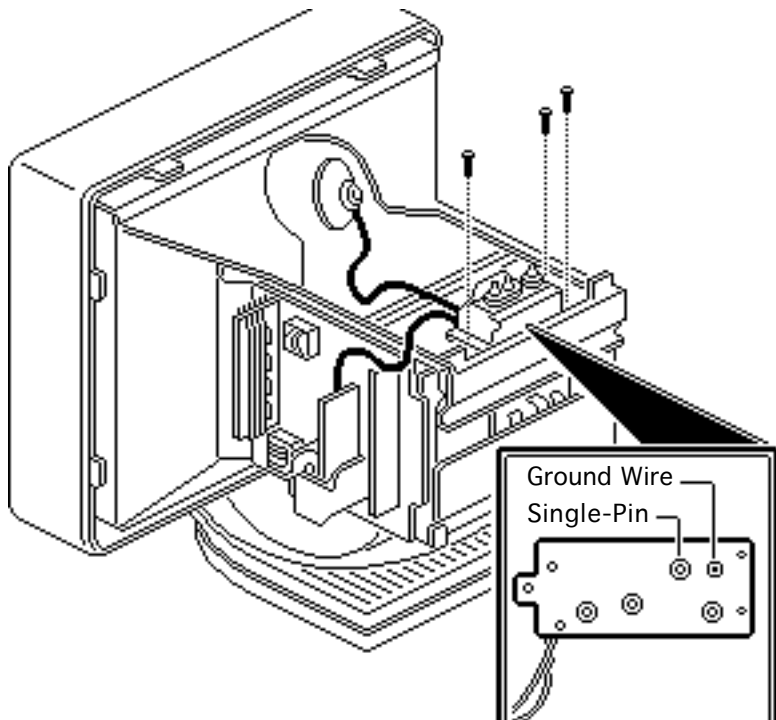

- 3 Remove the three screws that secure the high-voltage block to the chassis.
- 4 Tilt up the high-voltage block and disconnect the single-pin high-voltage cable and the flyback ground wire.



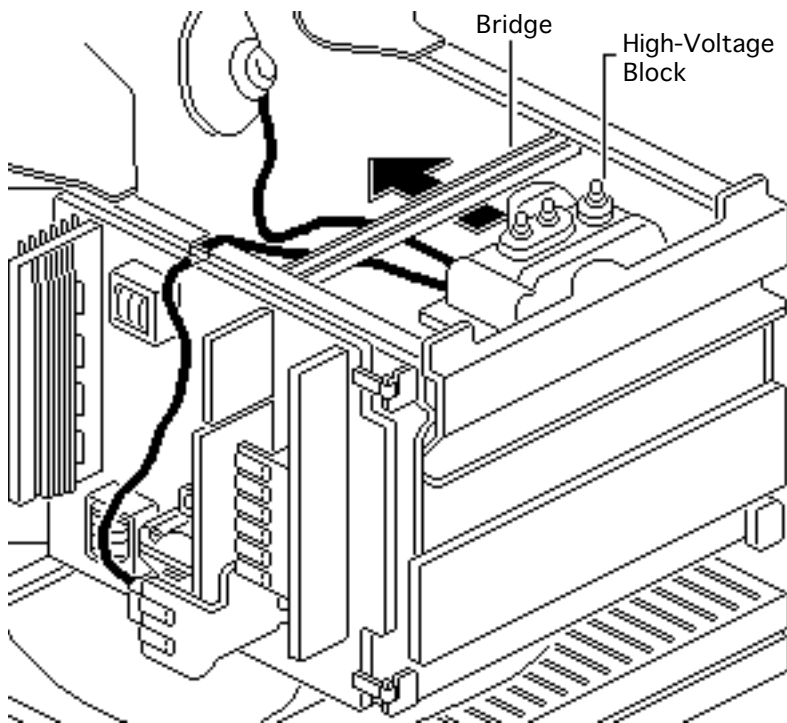

- 5 **Note:** To make removing the high-voltage block easier, unhook the bridge from the chassis and push it forward.

Slide the high-voltage block under the magnetometer coil bridge.



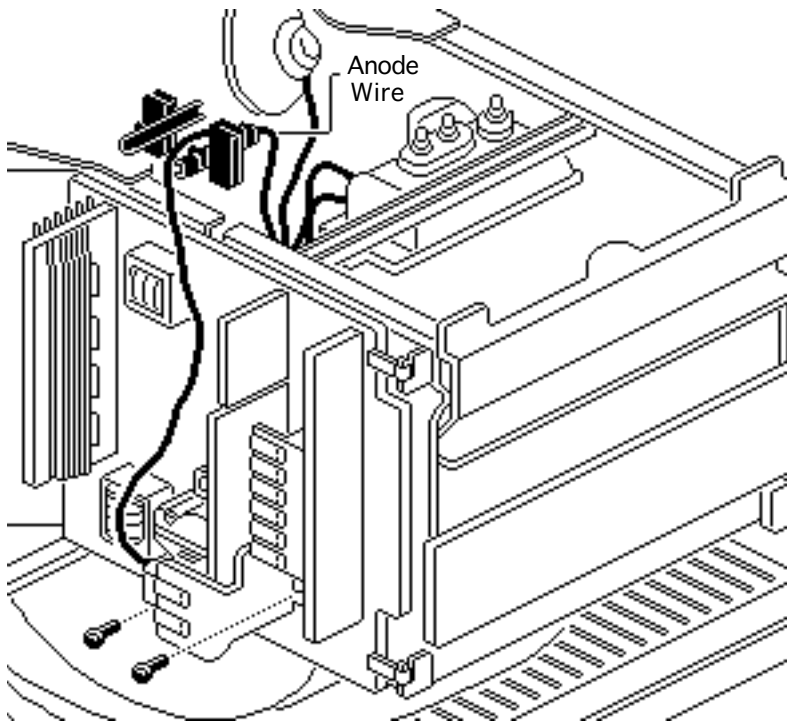

Flyback Transformer

- 1 Remove the anode wire from the breakaway cable holder on the chassis.
- 2 Remove the two screws that secure the flyback transformer to the main board.



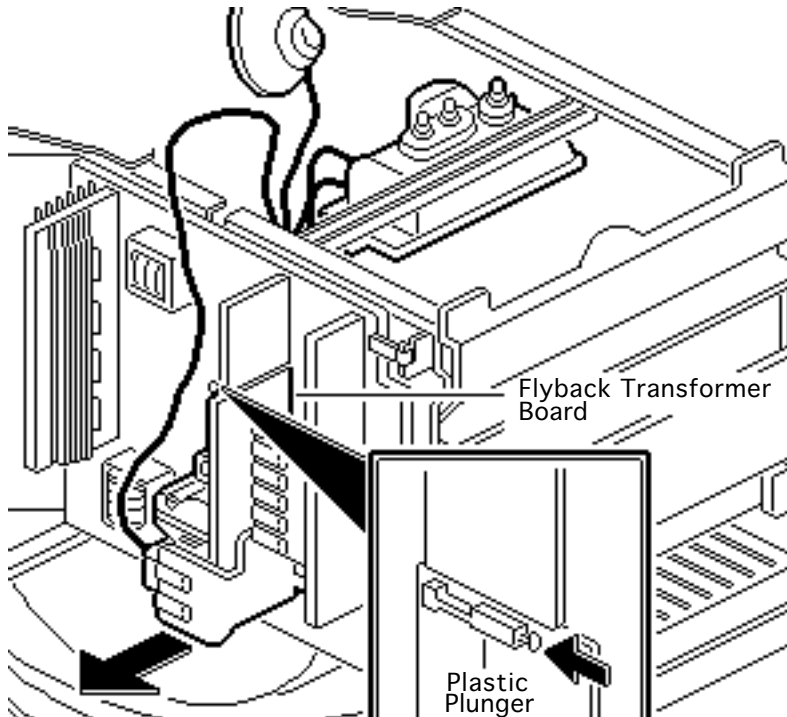

- 3 Push in the plastic plunger while disconnecting the flyback transformer board from main board connector X107. Remove the flyback transformer assembly.





Main Board

Before you begin,

- Remove the rear cover
- Remove the main board and CRT shields
- Discharge the CRT
- Remove the anode cap
- Remove the flyback transformer (only)

⚠ Warning: This product contains high voltage and a high-vacuum picture tube. To prevent serious injury, review CRT safety in Bulletins/Safety.

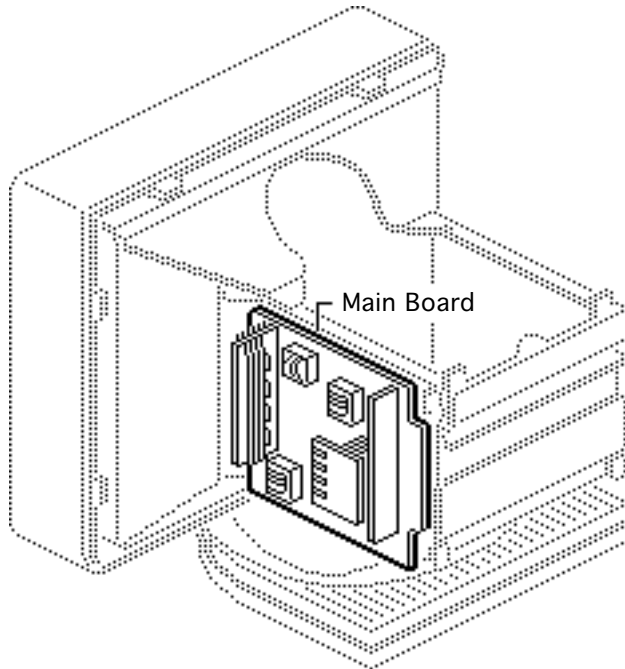

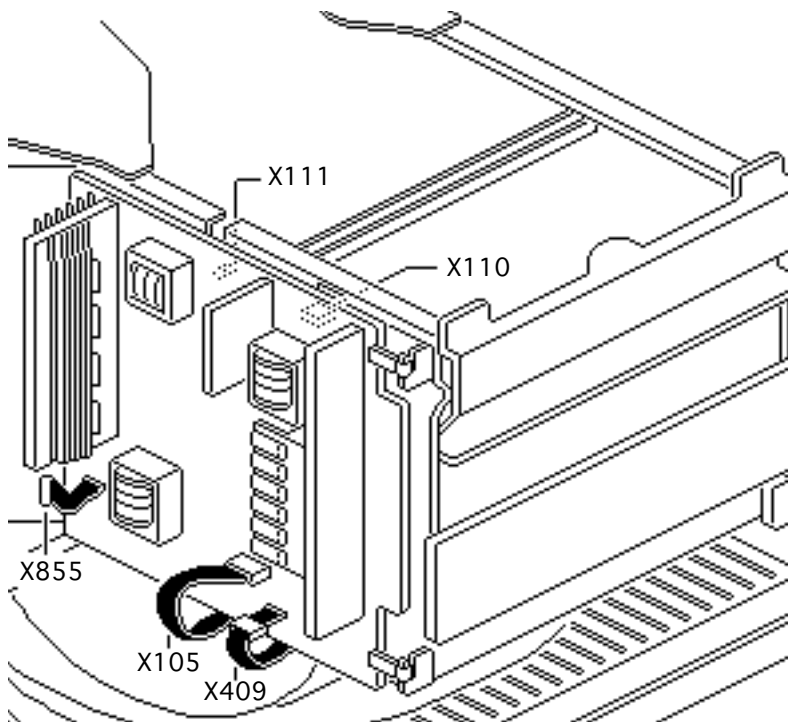

⚠ Warning: Never use a grounding wriststrap until after discharging the CRT.

Caution: If you are replacing the main board, make sure it is compatible with the CRT. Rev A CRTs require Rev A main boards; Rev B CRTs require Rev B main boards. See “Rev A/B Compatibility” in Additional Procedures.

- 1 Disconnect the following cable connectors from the main board:
 - 2-wire cable from X110





- Single-wire cable from X111
 - 8-pin ribbon cable from X105
 - 9-pin ribbon cable from video assembly connector X409.
- 2 Disconnect the 9-pin ribbon cable from magnetometer degauss board connector X855.



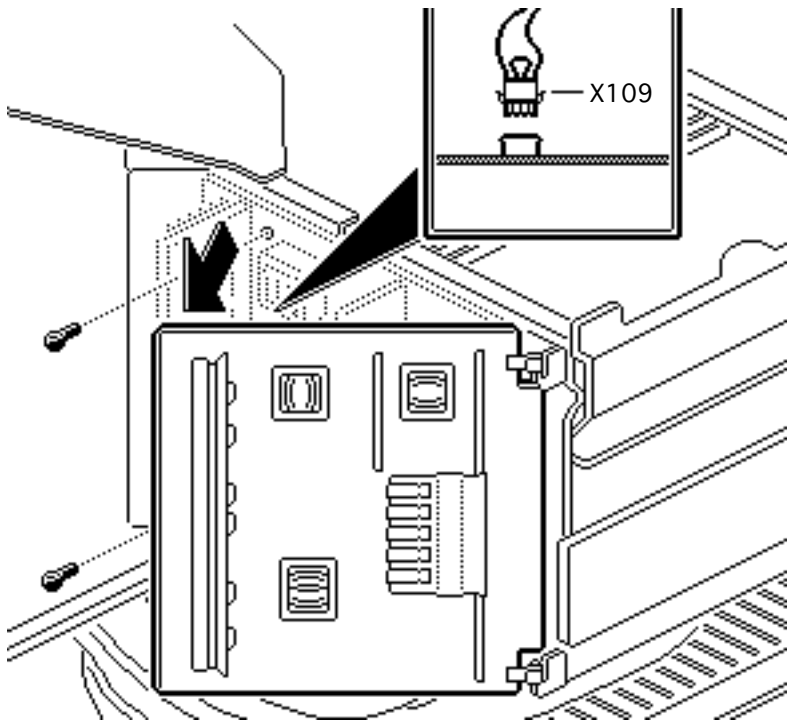

- 3 Remove the two screws that secure the main board to the chassis.
- 4 Partially open the main board and disconnect the 2-wire cable from connector X109 at the back of the main board.



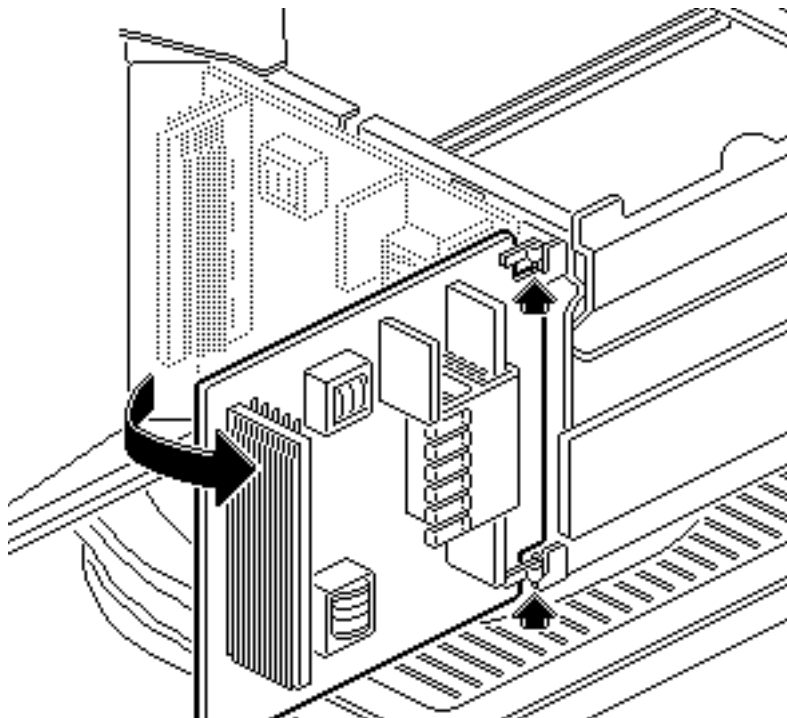

- 5 Open the main board until perpendicular to the chassis and lift it off the two hinges.

Replacement Caution:

If you are replacing the main board, make sure the replacement board is compatible with the CRT. Rev A CRTs require Rev A main boards; Rev B CRTs require Rev B main boards. See “Rev A/B Compatibility” in Additional Procedures.





Magnetometer Degauss Board

Before you begin,

- Remove the rear cover
- Remove the main board and CRT shields
- Discharge the CRT

⚠ Warning: This product contains high voltage and a high-vacuum picture tube. To prevent serious injury, review CRT safety in Bulletins/Safety.

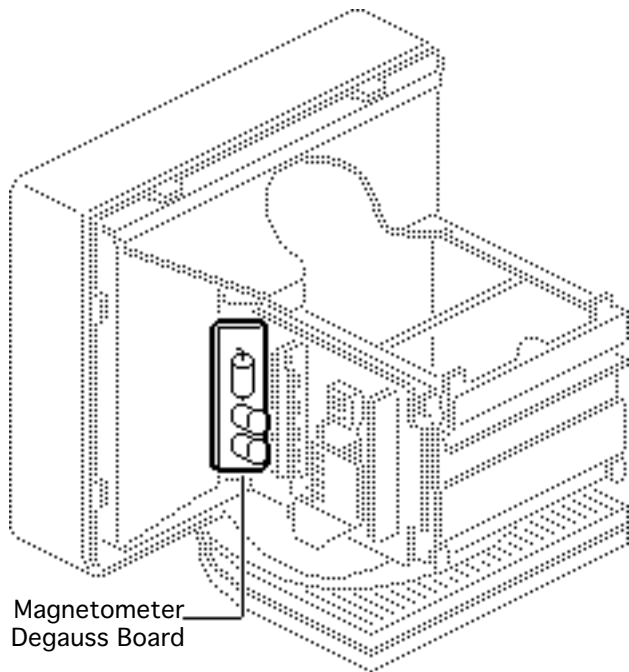

Magnetometer Degauss Board



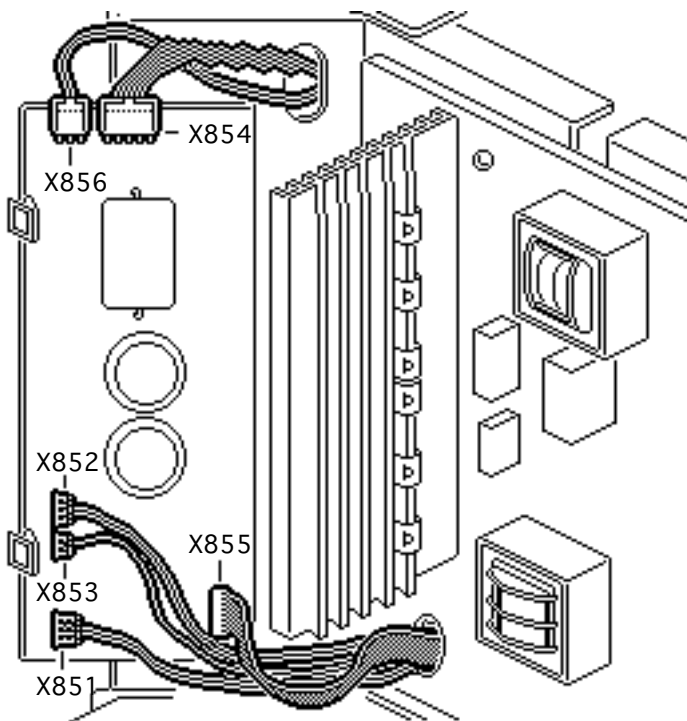

⚠ Warning: Never use a grounding wriststrap until after discharging the CRT.

1 Disconnect the following cable connectors from the magnetometer degauss board:

- 4-wire cable from X856
- 4-wire cable (with jumper) from X854
- 2-wire, 3-pin cable from X852
- 2-wire cable from X853
- 6-wire cable from X851



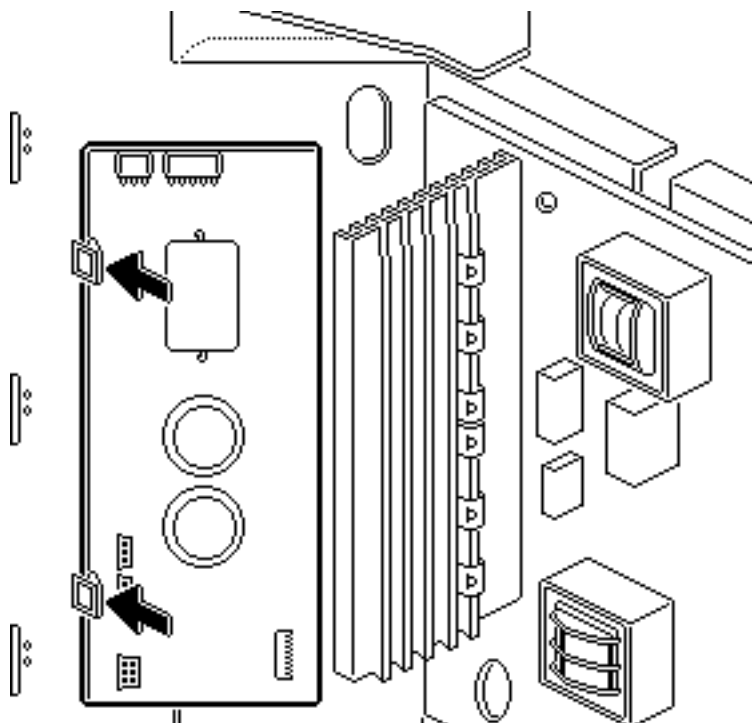

- 9-pin ribbon cable from X855
- 2 Pull open the two latches and remove the magnetometer degauss board.



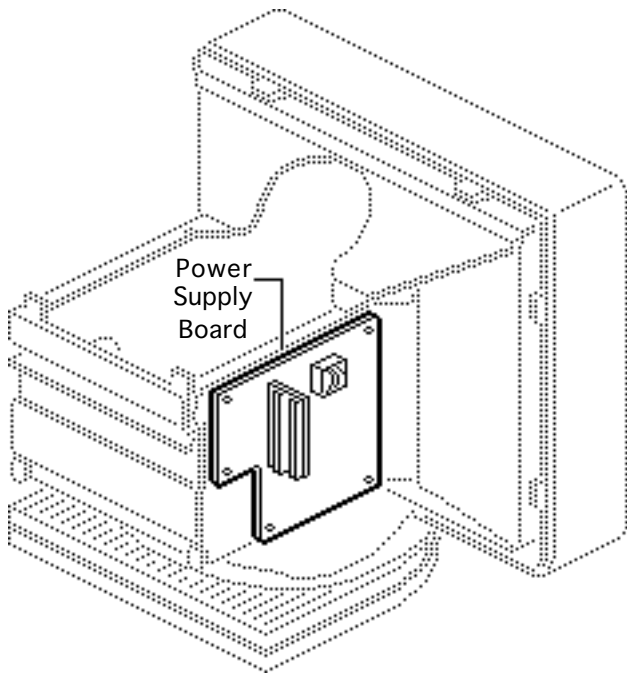

Power Supply Board

Before you begin,

- Remove the rear cover
- Remove the CRT shield
- Discharge the CRT
- Remove the power supply shield

⚠ Warning: This product contains high voltage and a high-vacuum picture tube. To prevent serious injury, review CRT safety in Bulletins/Safety.



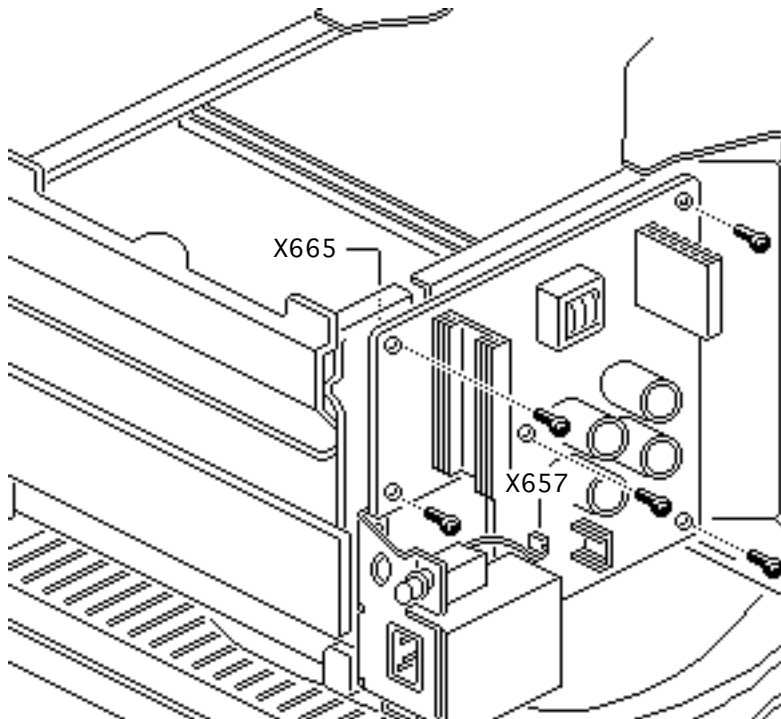

⚠ Warning: Never use a grounding wriststrap until after discharging the CRT.

- 1 Disconnect the 8-pin ribbon cable from connector X665 (at the back of the power supply board) and the 2-wire power cable from connector X657.
- 2 Remove the six screws that secure the power supply board to the chassis.



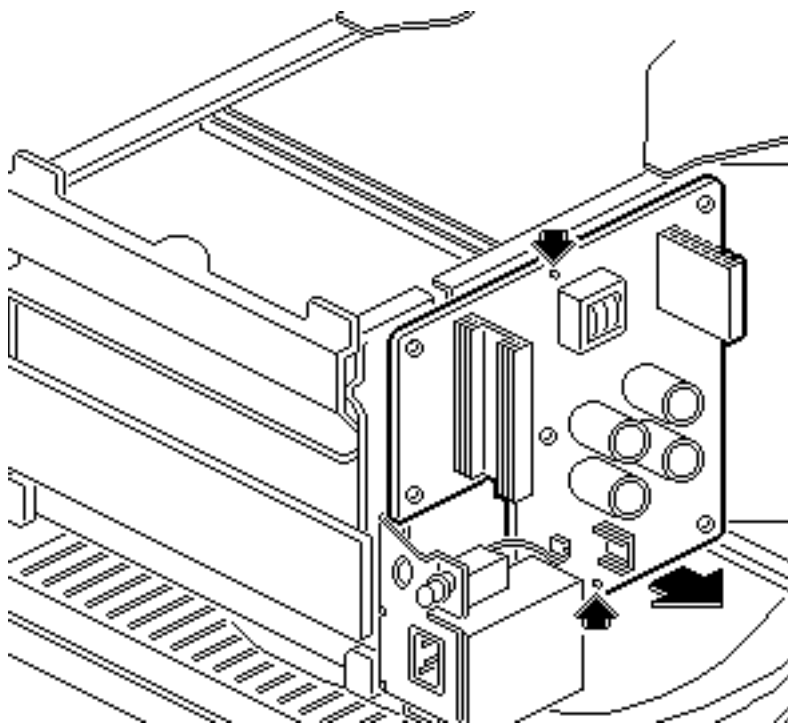

- 3 Using needlenose pliers, press the two plastic standoffs and remove the power supply board.





On/Off Switch

Before you begin,

- Remove the rear cover
- Remove the CRT shield
- Discharge the CRT
- Remove the power supply shield

⚠ Warning: This product contains high voltage and a high-vacuum picture tube. To prevent serious injury, review CRT safety in Bulletins/Safety.

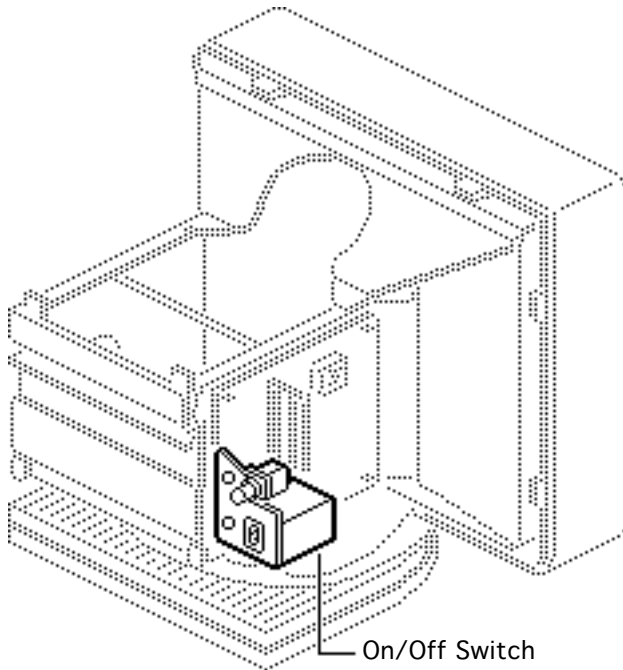

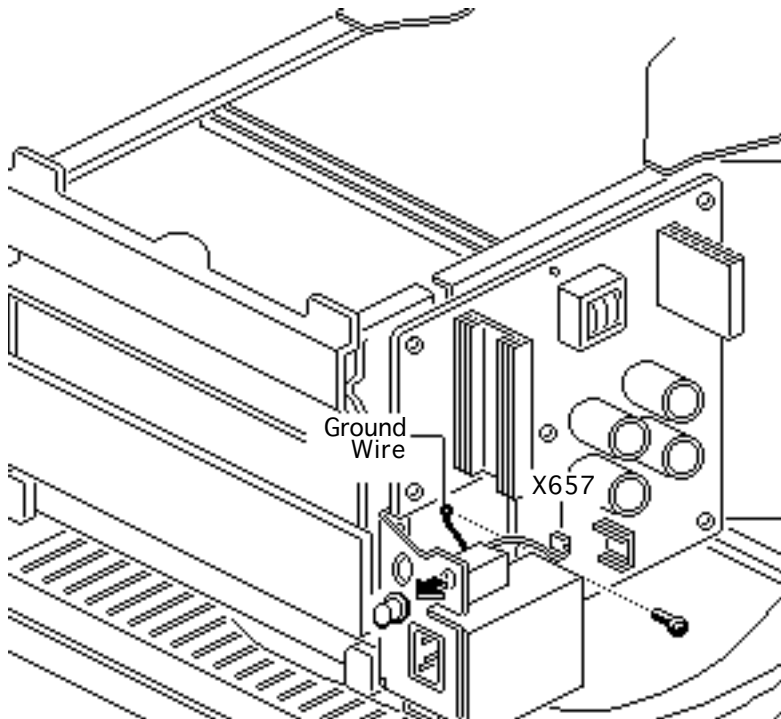

⚠ Warning: Never use a grounding wriststrap until after discharging the CRT.

- 1 Disconnect the 2-wire power cable from power supply board connector X657.
- 2 Remove the screw that secures the on/off switch ground wire to the chassis.
- 3 Pull off the plastic knob.





- 4 Remove the mounting screw and the on/off switch from the chassis.

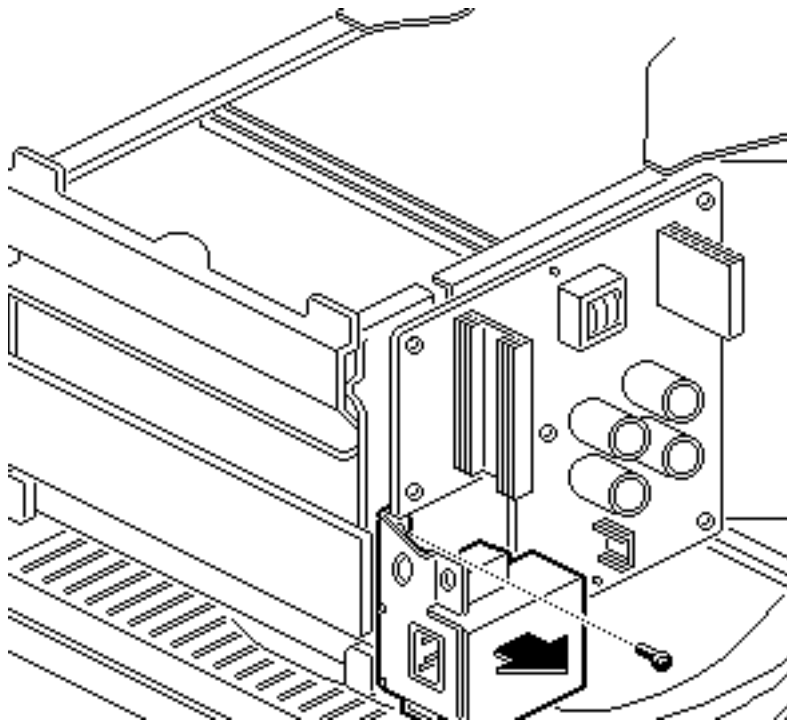



Video Assembly

Before you begin,

- Remove the rear cover
- Remove the CRT shield
- Discharge the CRT
- Remove the main board shield

⚠ Warning: This product contains high voltage and a high-vacuum picture tube. To prevent serious injury, review CRT safety in Bulletins/Safety.

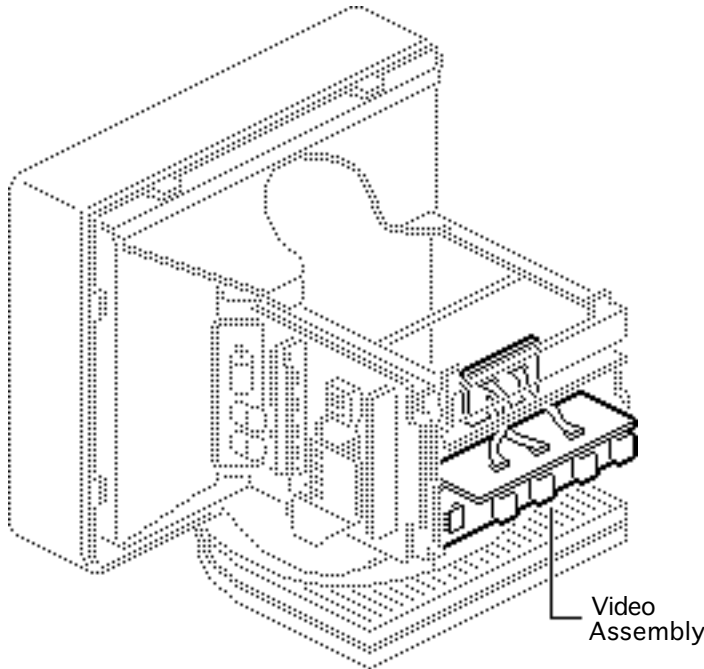

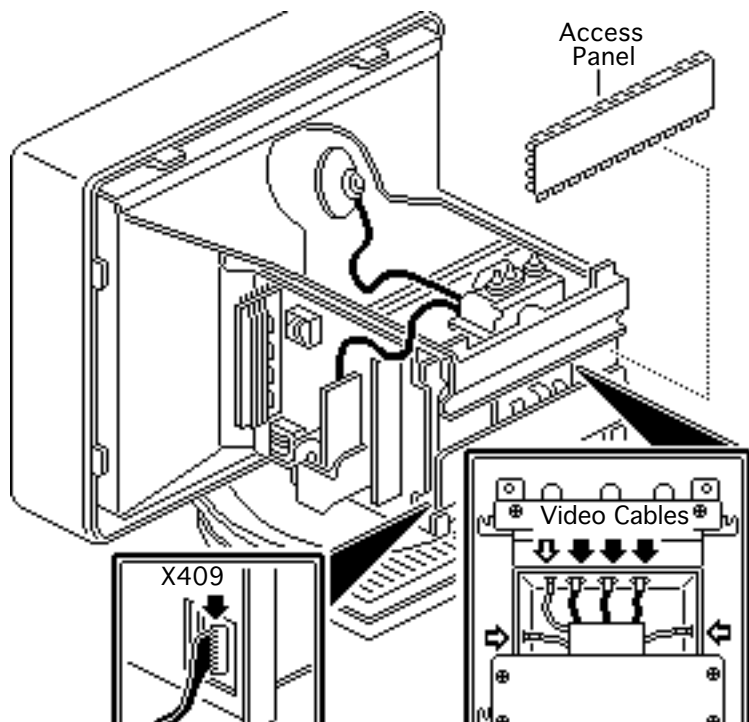

⚠ Warning: Never use a grounding wriststrap until after discharging the CRT.

- 1 Disconnect the main board ribbon cable from video assembly connector X409.
- 2 Pull the CRT/video board access panel off the rear of the chassis.
- 3 Disconnect the three video cables from the bottom of the high-voltage block.

Replacement Caution:
The three video cables



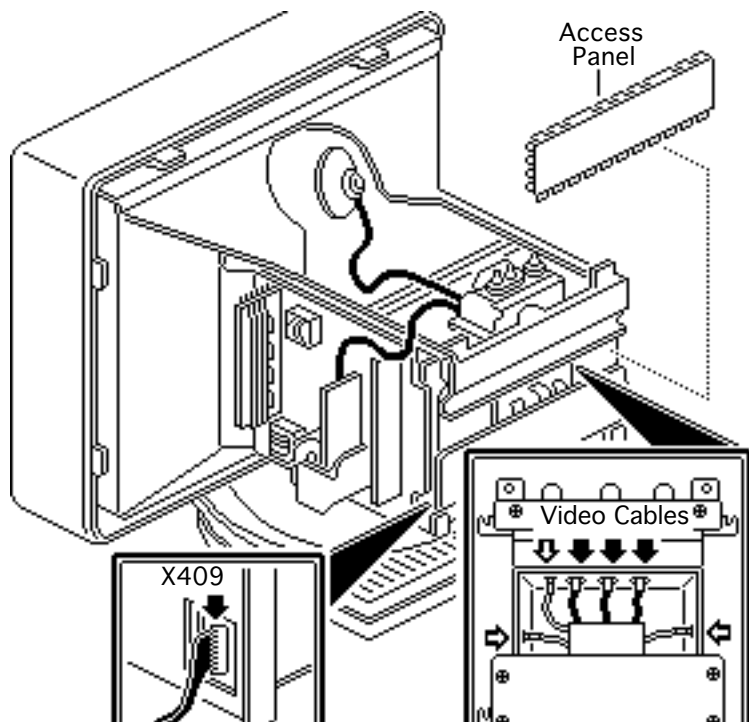

are not interchangeable. Be sure to connect these color-coded cables to the terminals labeled with the same color.

- 4 Disconnect the three ground cables from the chassis.



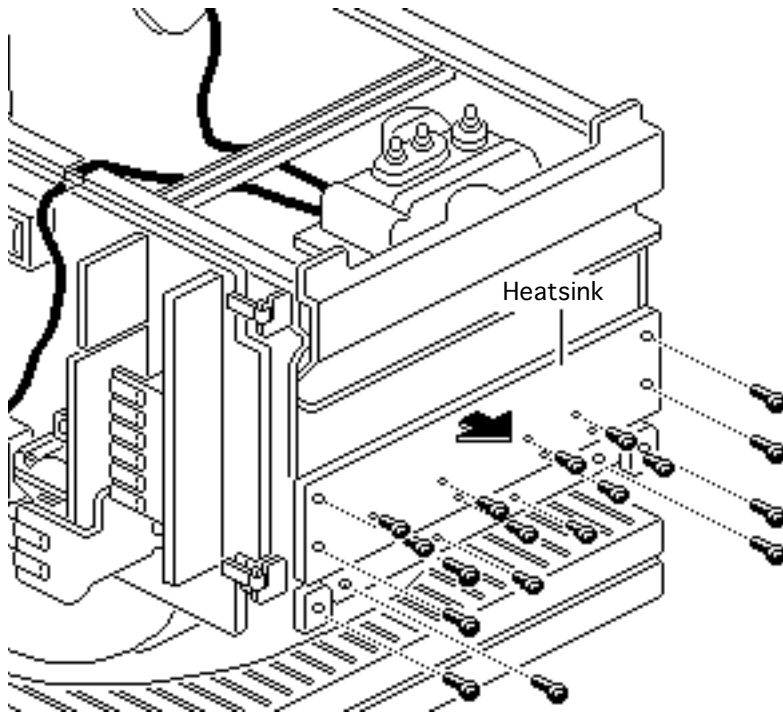

- 5 Remove these mounting screws from the video assembly heatsink:
 - 8 Phillips with captive lockwashers
 - 8 sheet metal (short)
 - 2 sheet metal from the video cable connector (short)
- 6 Remove the heatsink.
- 7 **Caution:** Be sure to pull the CRT/video board straight off the neck of the CRT. Twisting, bending, or applying force to the board could damage the CRT.



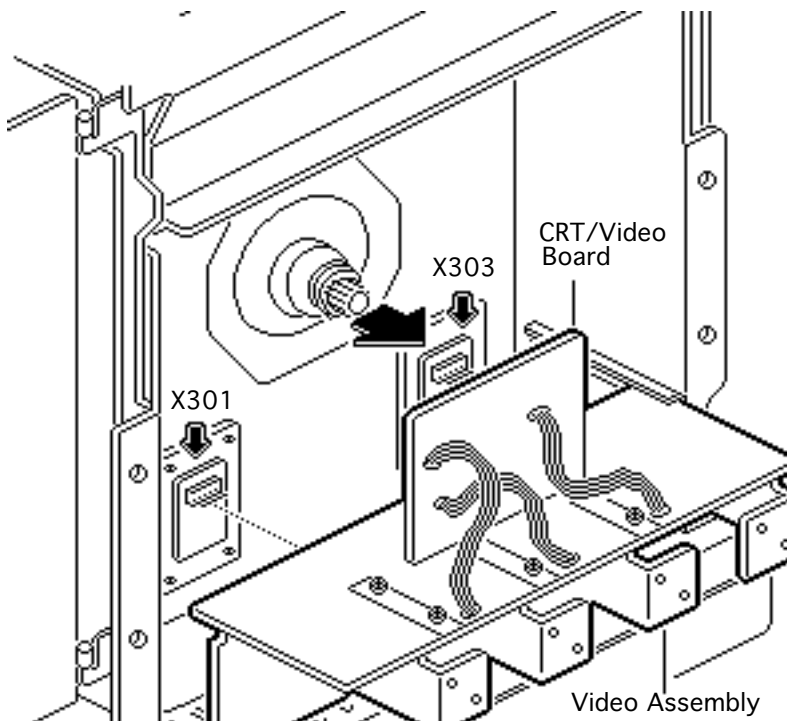

Carefully pull the CRT/video board straight off the neck of the CRT.

- 8 Pull out the video assembly, disconnecting it from connectors X301 and X303 on the left and right video filter boards.

Replacement Note: Position the video assembly using the two plastic mounting channels and push in firmly to connect the video assembly to the video filter board connectors.





Video Filter Boards

Before you begin,

- Remove the rear cover
- Remove the CRT shield
- Discharge the CRT
- Remove the main board shield
- Remove the video assembly

⚠ Warning: This product contains high voltage and a high-vacuum picture tube. To prevent serious injury, review CRT safety in Bulletins/Safety.

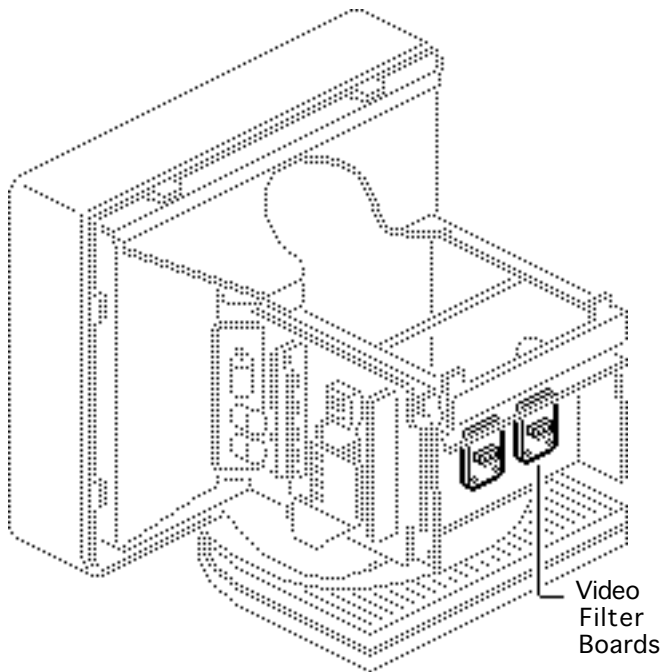

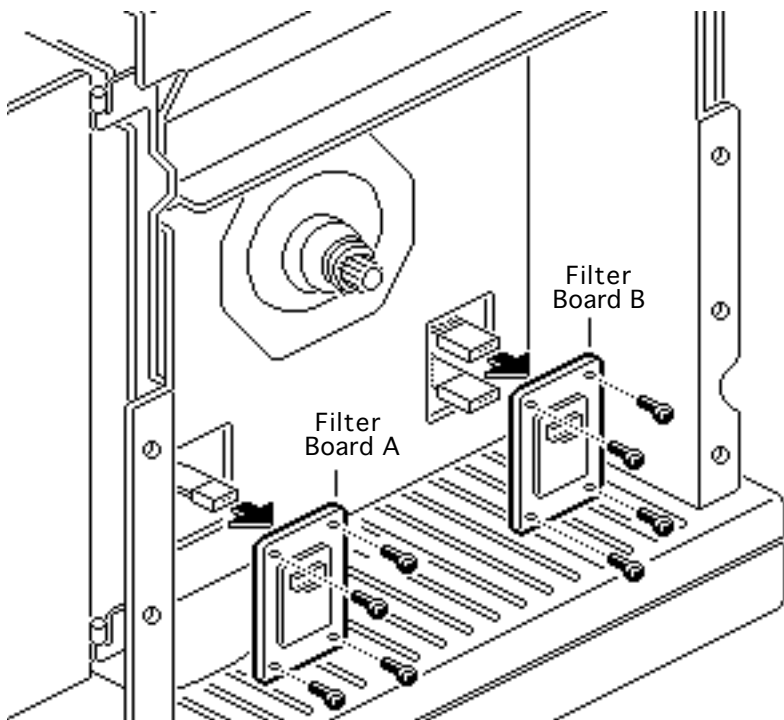

⚠ Warning: Never use a grounding wriststrap until after discharging the CRT.

Note: Video filter boards A and B are replaced as a set.

- 1 Remove the four sheet metal mounting screws from each video filter board. Pull the boards with attached ribbon cables partially through the openings in the chassis.
- 2 Disconnect the narrow ribbon cable from video filter board A.



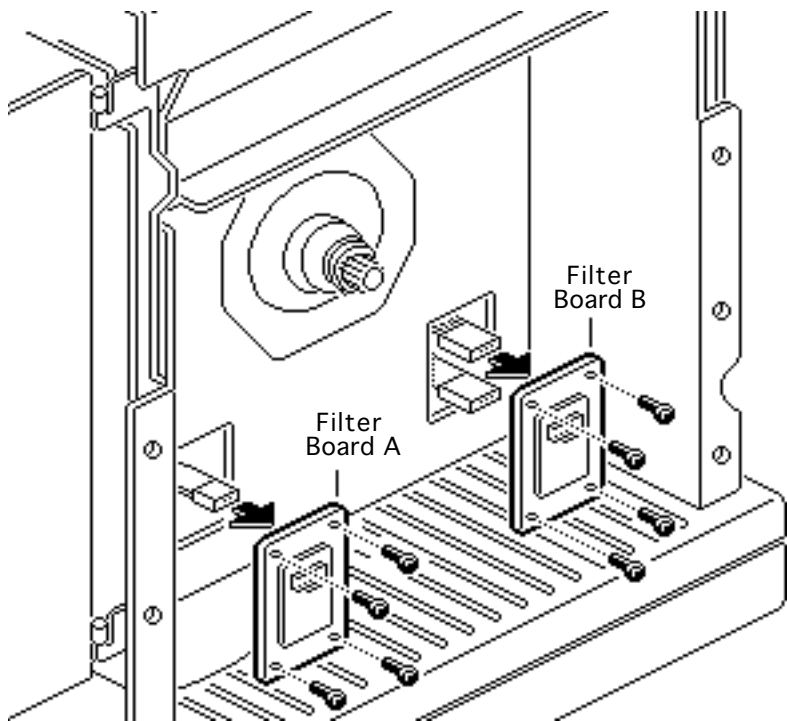

- 3 Disconnect the wide ribbon cable and the 3-wire, 7-pin cable from video filter board B.



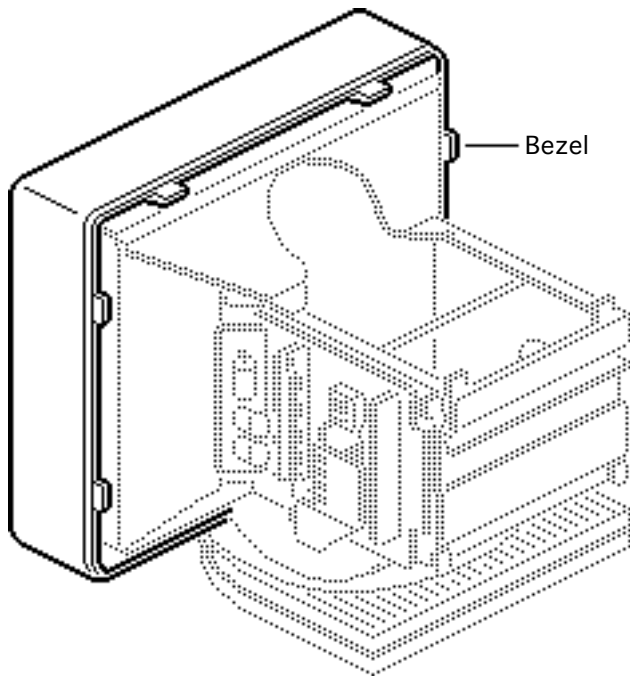

Bezel

Before you begin,

- Remove the rear cover
- Remove the shields
- Discharge the CRT

⚠ Warning: This product contains high voltage and a high-vacuum picture tube. To prevent serious injury, review CRT safety in Bulletins/Safety.

⚠ Warning: Never use a grounding wriststrap until after discharging the CRT.



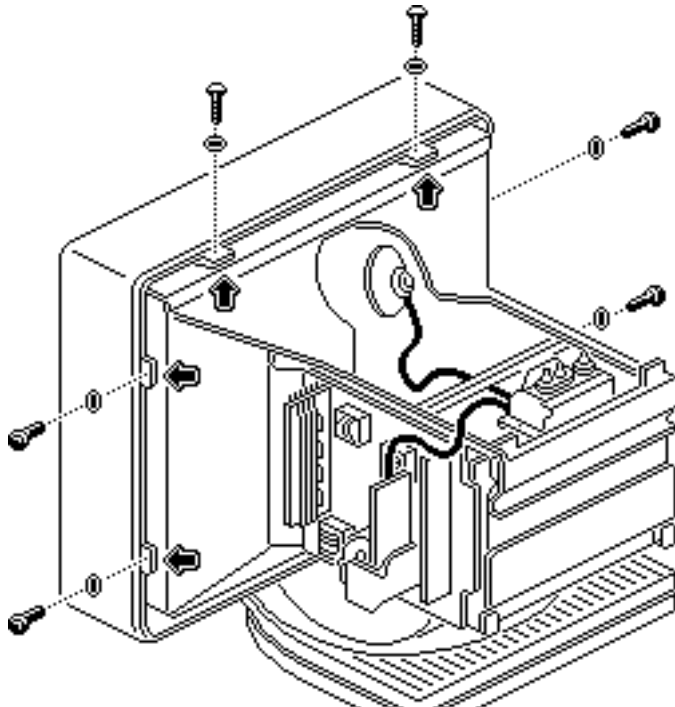

- 1 Remove the six screws and washers that secure the bezel latches to the chassis.
- 2 Release the six bezel latches and pull the bezel slightly away from the chassis.



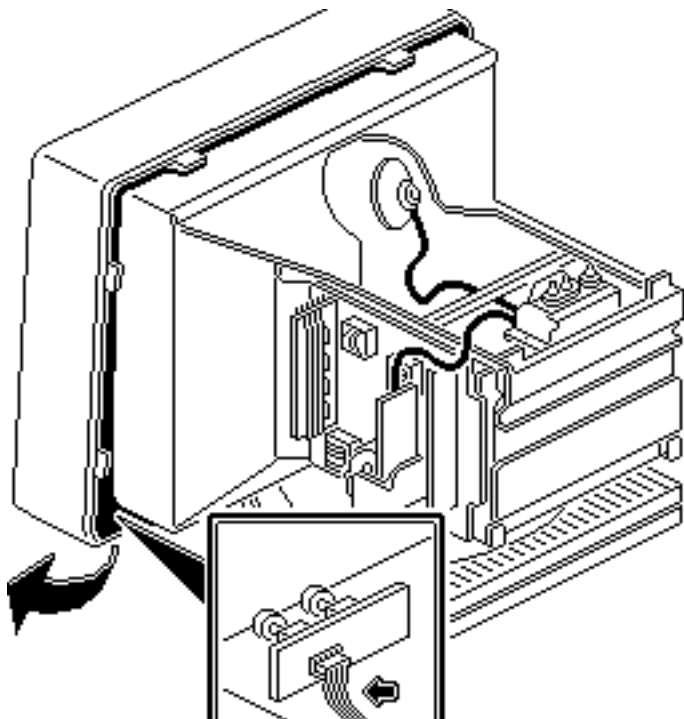

- 3 Tilt up the monitor and pull out the bottom of the bezel. Reach beneath the bezel and disconnect the ribbon cable from the contrast/brightness assembly.
- 4 Pull the bezel off the chassis.





Contrast/ Brightness and LED

Before you begin,

- Remove the rear cover
- Remove the shields
- Discharge the CRT
- Remove the bezel

⚠ Warning: This product contains high voltage and a high-vacuum picture tube. To prevent serious injury, review CRT safety in Bulletins/Safety.

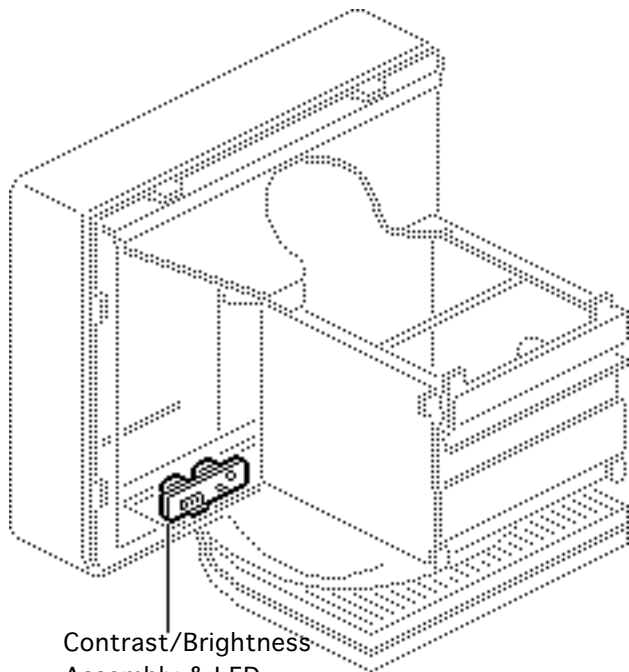

Contrast/Brightness
Assembly & LED



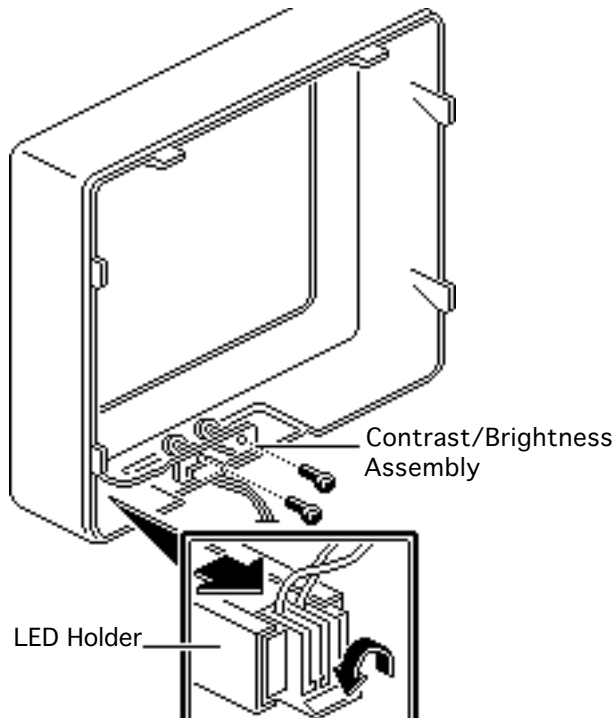

⚠ Warning: Never use a grounding wriststrap until after discharging the CRT.

- 1 Press the clear plastic tab and remove the LED from the LED holder. Pull out the LED lamp.
- 2 Remove the two mounting screws and the contrast/brightness assembly from the bezel. Pull off and keep the two knobs.





Magnetometer Coils

Before you begin,

- Remove the monitor stand
- Remove the rear cover
- Remove the shields
- Discharge the CRT and remove the anode cap
- Remove the flyback assembly
- Remove the main board
- Remove the bezel
- Remove the CRT

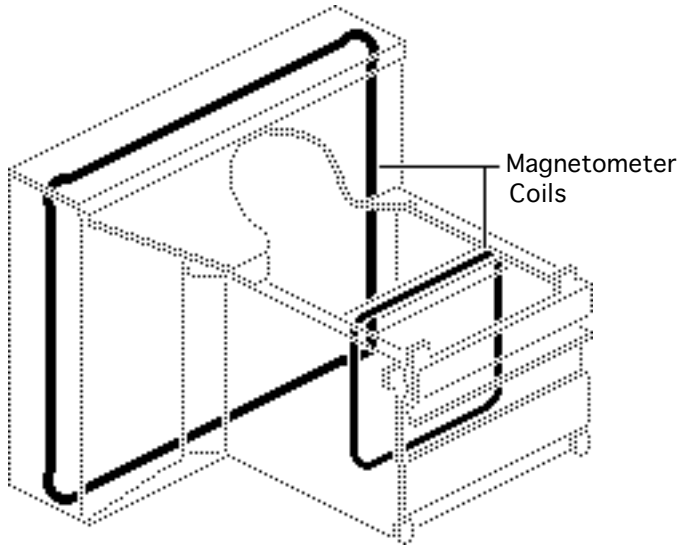



⚠ Warning: This product contains high voltage and a high-vacuum picture tube. To prevent serious injury, review CRT safety in Bulletins/Safety.

⚠ Warning: Never use a grounding wriststrap until after discharging the CRT.

Note: The front and rear magnetometer coils are replaced as a set.





Front Magnetometer Coil

- 1 Remove the two nuts from the upper CRT mounting bolts.
- 2 Unhook the front magnetometer coil from the upper, and then the lower, mounting bolts.

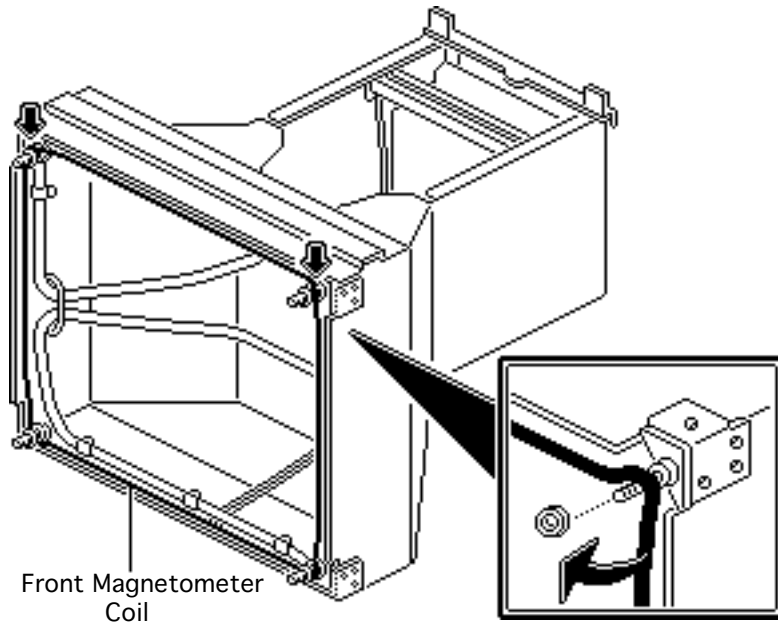

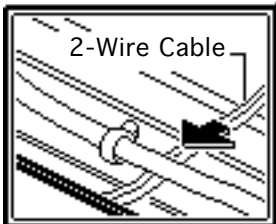
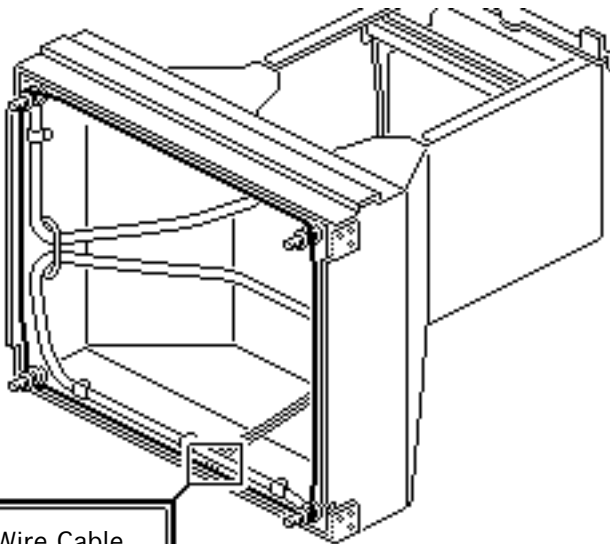

- 3 Pull the 2-wire magnetometer cable under the white degauss coil, and remove the front magnetometer coil from the chassis.



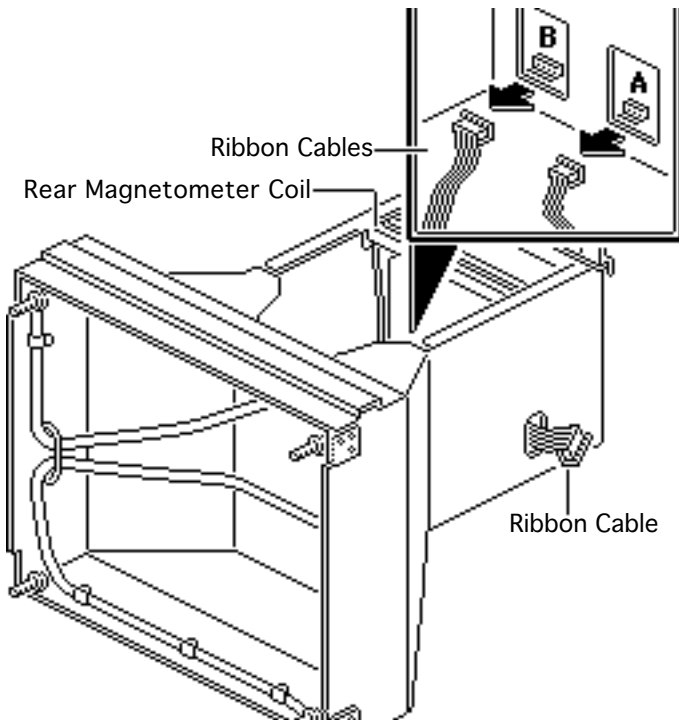

Rear Magnetometer Coil

- 1 Disconnect the two ribbon cables from the connectors at the back of the A and B video filter boards.
- 2 Pull the ribbon cable through the main board access hole in the chassis.



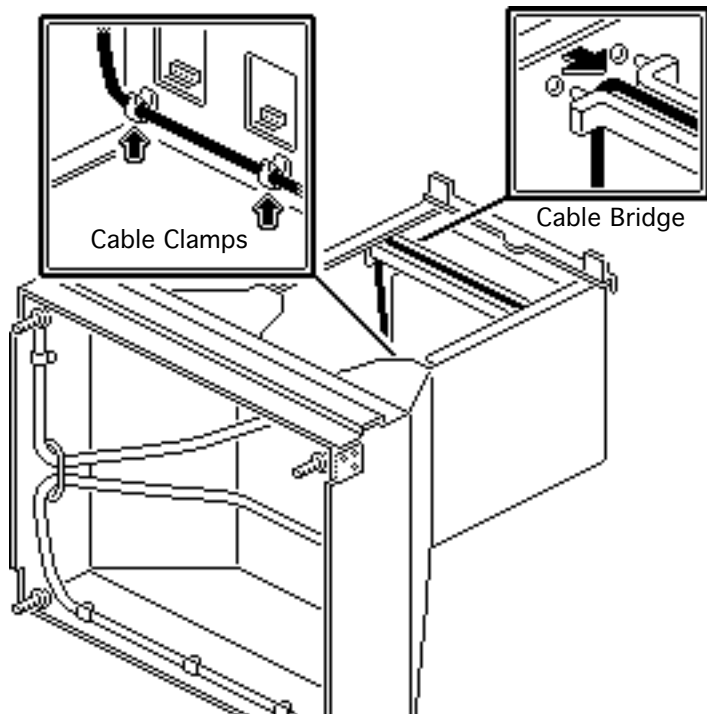

- 3 Unhook the bottom of the rear magnetometer coil from the two cable clamps.
- 4 Unhook the cable bridge from the chassis.



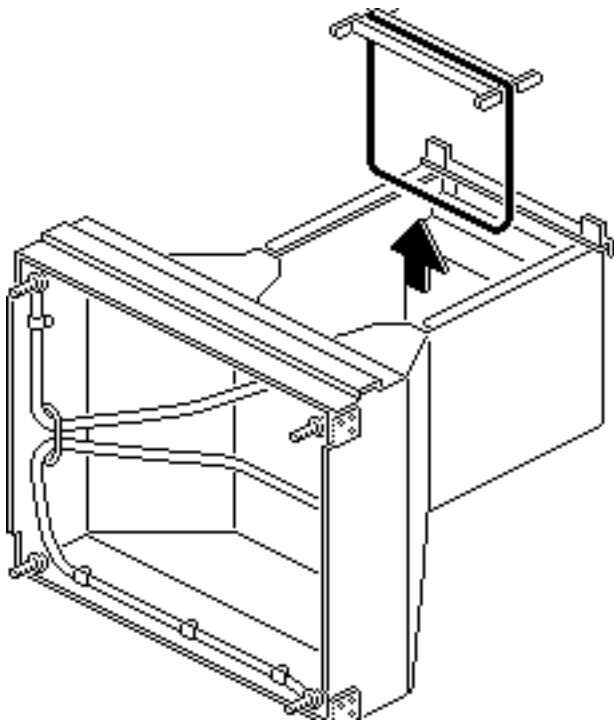

- 5 Lift the rear magnetometer coil (with attached cable bridge) over the ribbon cables and out of the chassis.

Replacement Caution:
Replace the magnetometer coils with the arrows taped to the coils pointing in the same direction as the arrows stamped on the chassis.





Degauss Coils

Before you begin,

- Remove the monitor stand
- Remove the rear cover
- Remove the shields
- Discharge the CRT and remove the anode cap
- Remove the flyback assembly
- Remove the main board
- Remove the bezel
- Remove the CRT

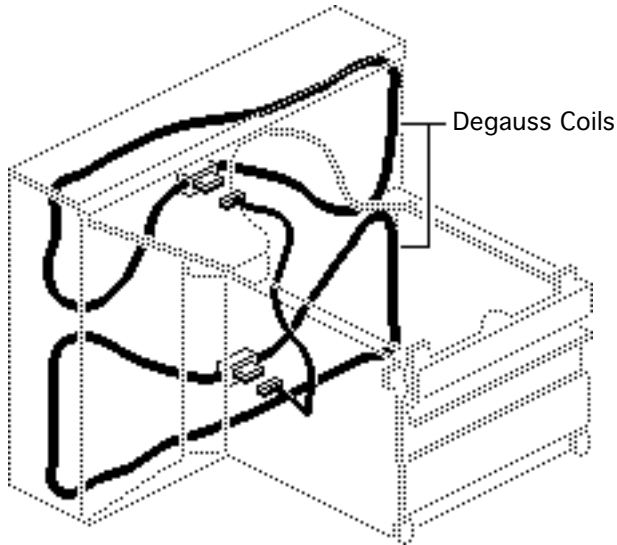



⚠ Warning: This product contains high voltage and a high-vacuum picture tube. To prevent serious injury, review CRT safety in Bulletins/Safety.

⚠ Warning: Never use a grounding wriststrap until after discharging the CRT.

Note: The upper and lower degauss coils are replaced as a set. The coils are interchangeable.



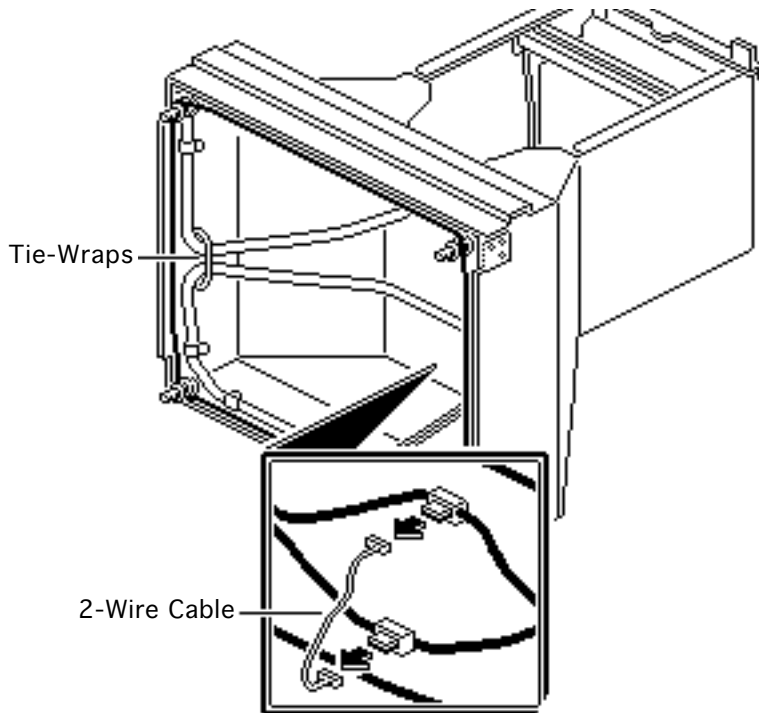

- 1 Disconnect the 2-wire cable from the upper and lower degauss coils.
- 2 Using a wirecutter, cut the tie-wraps that secure the degauss coils to the chassis.



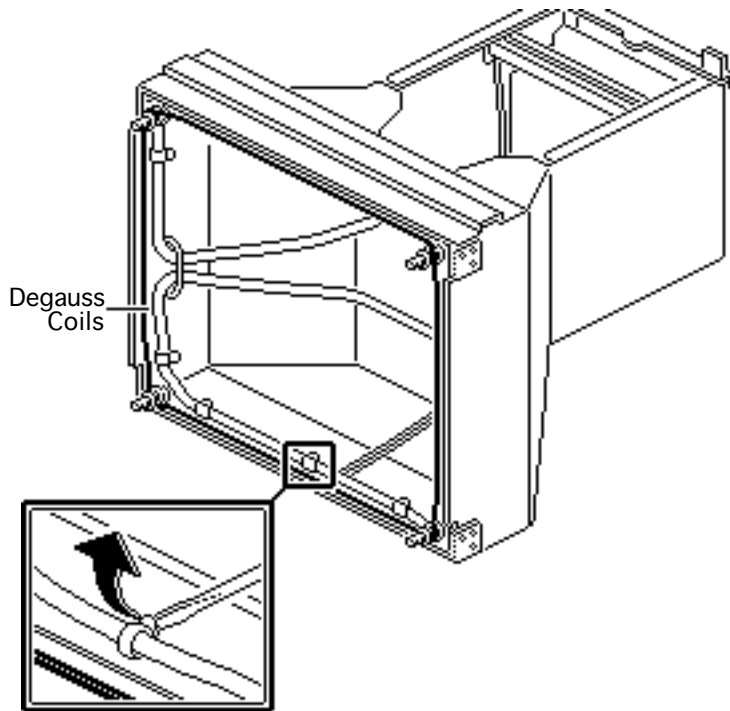

- 3 Using a small flat-blade screwdriver, pry open the 10 cable fasteners and remove the upper and lower degauss coils.





CRT (International Only)

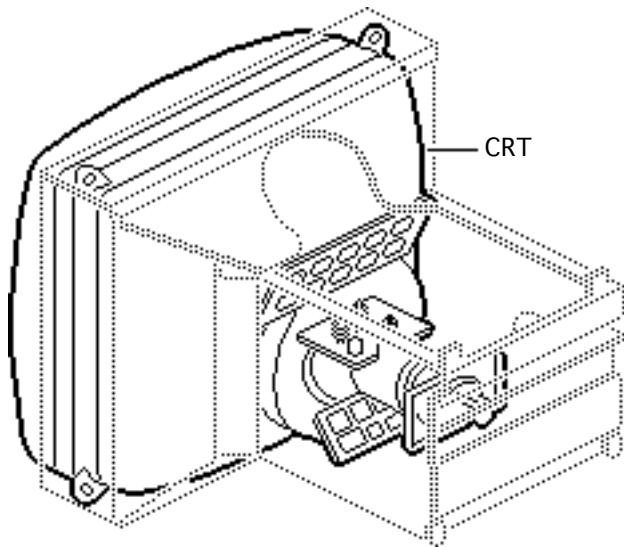

Before you begin,

- Remove the monitor stand
- Remove the rear cover
- Remove the shields
- Discharge the CRT and remove the anode cap
- Remove the flyback assembly
- Remove the main board
- Remove the bezel

⚠ Warning: This product contains high voltage and a





high-vacuum picture tube.
To prevent serious injury,
review CRT safety in
Bulletins/Safety.

⚠ Warning: Never use a
grounding wriststrap until
after discharging the CRT.

Important: This procedure
is for international repair
technicians only. If
domestic technicians suspect
that a customer's CRT is
defective, call your
Technical Operations
Specialist.



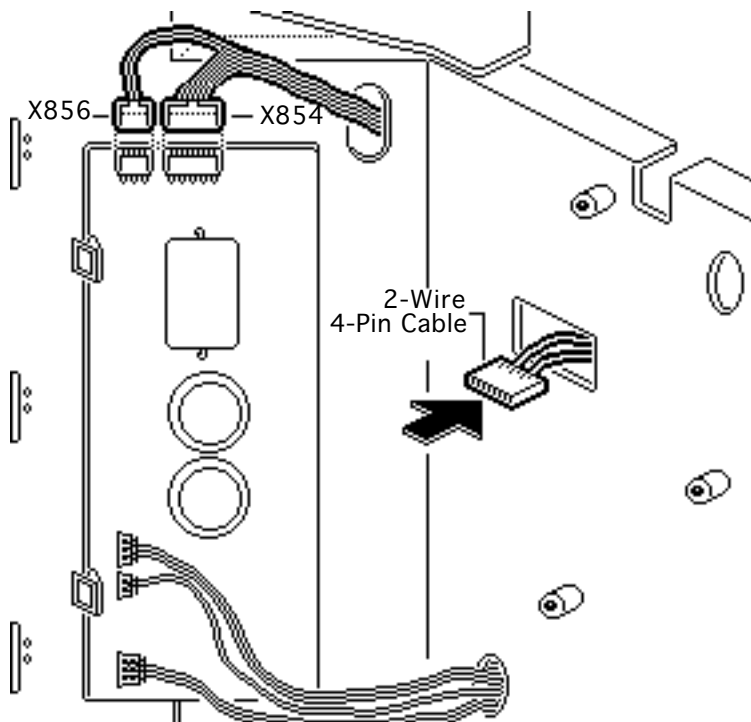

- 1 Push the 2-wire, 4-pin cable through the rectangular access hole in the chassis.
- 2 Disconnect the 4-wire cable from connector X856 and the 4-wire cable (with internal jumper) from connector X854 on the magnetometer degauss board.
- 3 Push these cables through the oblong access hole in the chassis.



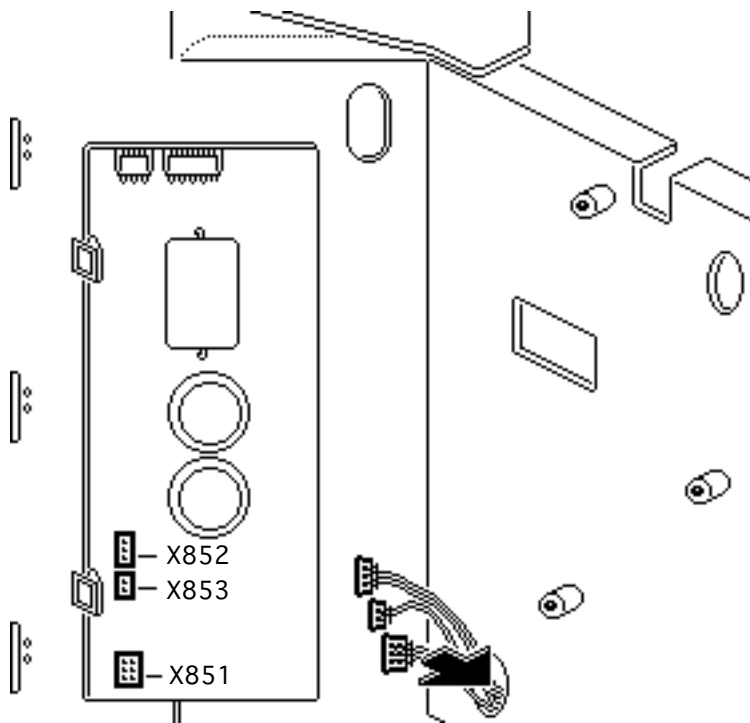

- 4 Disconnect the following cable connectors from the magnetometer degauss board:
 - 2-wire, 3-pin cable from X852
 - 2-wire cable from X853
 - 6-wire cable from X851
- 5 Push these cables through the round access hole in the chassis.



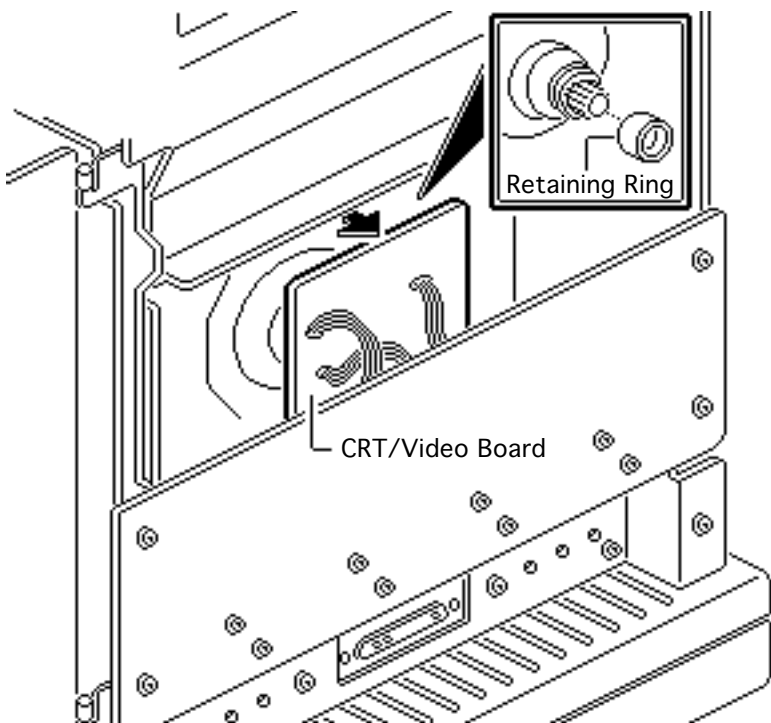

- 6 **Caution:** Twisting, bending, or applying force to the CRT/video board could damage the neck of the CRT. Be sure to pull the CRT/video board straight off the CRT.

Carefully pull the CRT/video board straight off the neck of the CRT.

- 7 Remove the plastic retaining ring from the neck of the CRT.



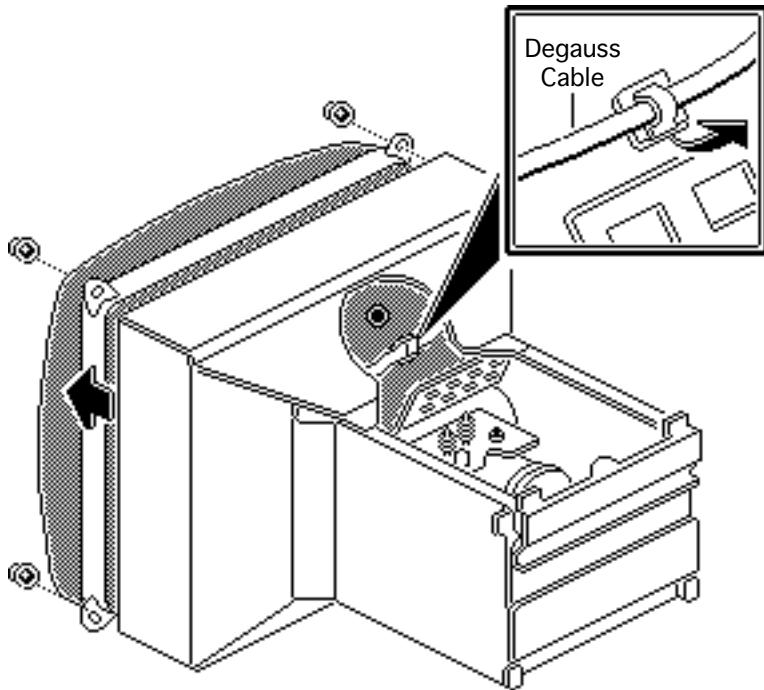

- 8 Using an adjustable wrench, remove the four nuts that secure the CRT to the chassis.
- 9 Remove the upper (white) degauss cable from the cable clamp on the CRT.



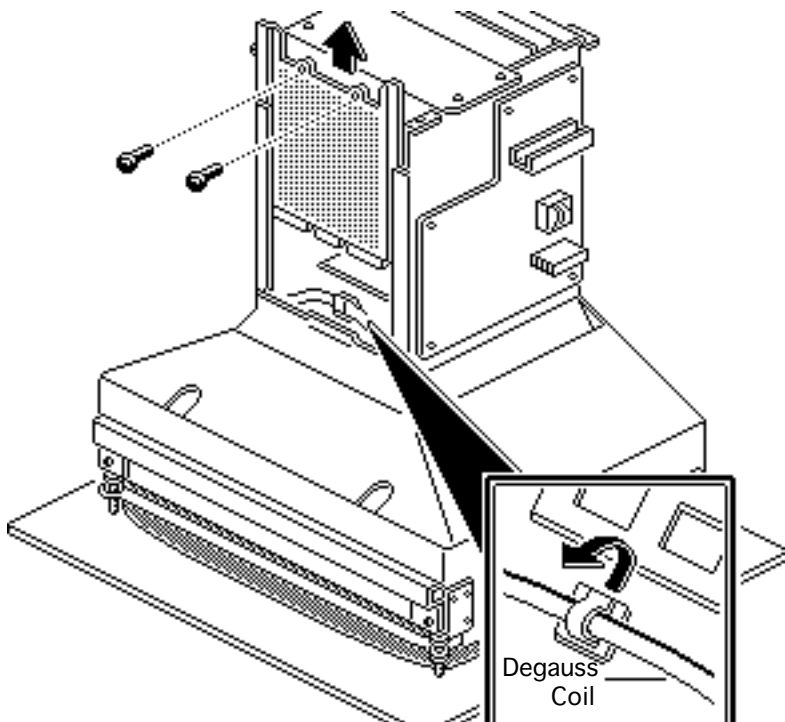

10 Underneath the chassis, remove the two sheet metal screws and the lower degauss coil access panel.

11 Remove the lower degauss coil from the cable clamp on the CRT.



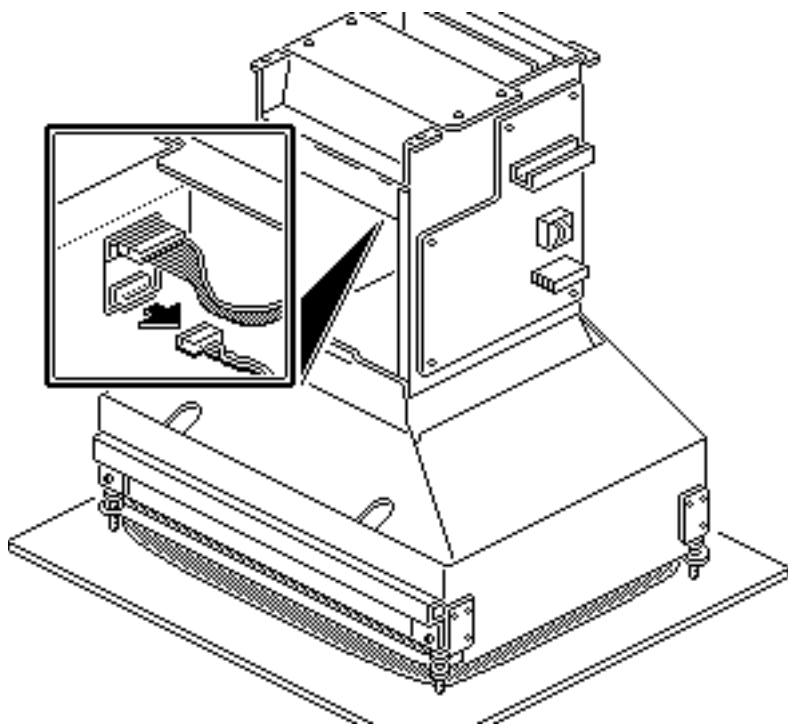

- 12 Disconnect the 3-wire, 7-pin yoke cable from the back of video filter board B.



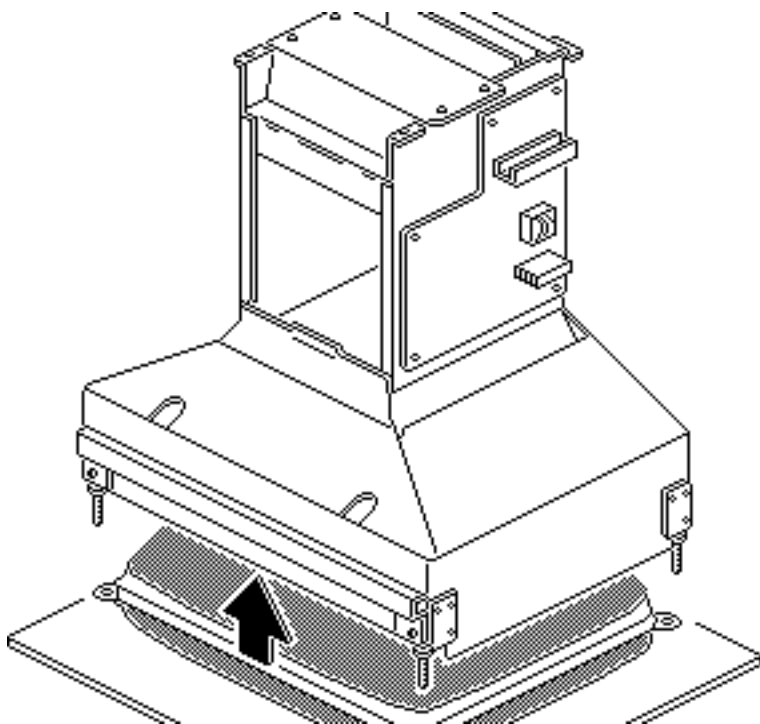

⚠ Warning: The CRT weighs more than 50 pounds. When handling the CRT, always wear eye protection and carry the CRT with two hands firmly grasping the CRT faceplate and metal rim.

13 **Caution:** When lifting the chassis off the CRT, make sure all loose cables are cleared from the neck of the CRT.

Carefully pull the chassis (with attached modules) off the CRT and lift it straight up over the neck of the CRT.





Important: Always devacuum a defective CRT before disposing of it. Because color CRTs contain lead, you must dispose of defective color CRTs according to local hazardous-waste ordinances. Refer to CRT disposal instructions in Bulletins/Safety.



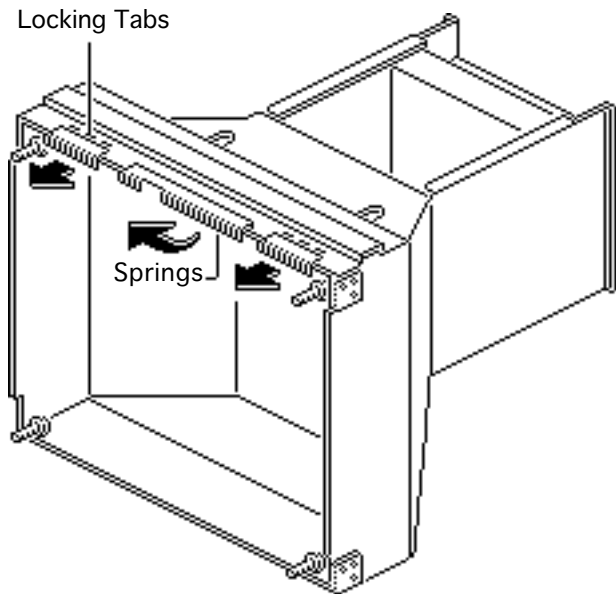

Replacement Note: Before replacing the chassis on the CRT, press the locking tabs and pull the three sets of springs off the chassis. Reinstall these springs after you have replaced the chassis on the CRT.



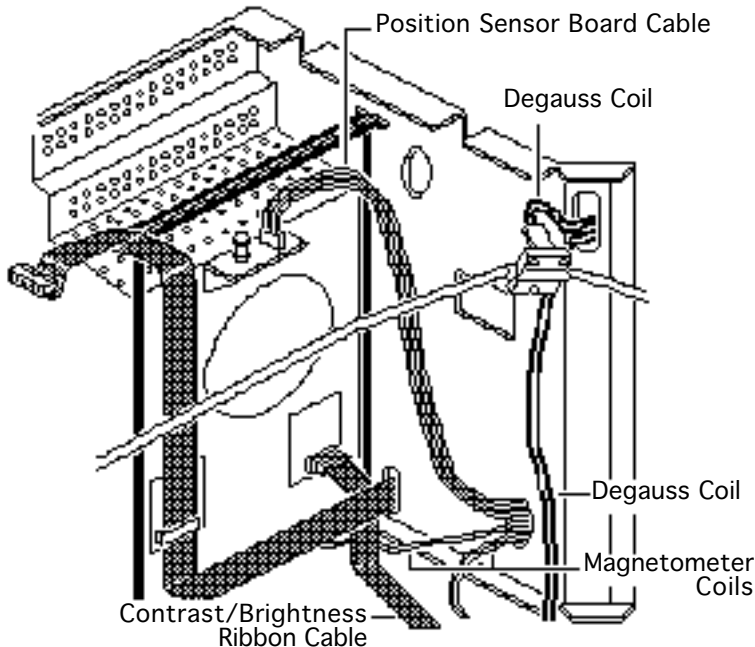

Replacement Note: Before replacing the chassis on the CRT, lace these cables through the proper chassis access holes:

- 4-wire degauss coil through the oblong access hole
- Two, 2-wire magnetometer coils through the circular access hole
- 6-wire position sensor board cable through the circular access hole
- Contrast/brightness ribbon cable out the front of the chassis



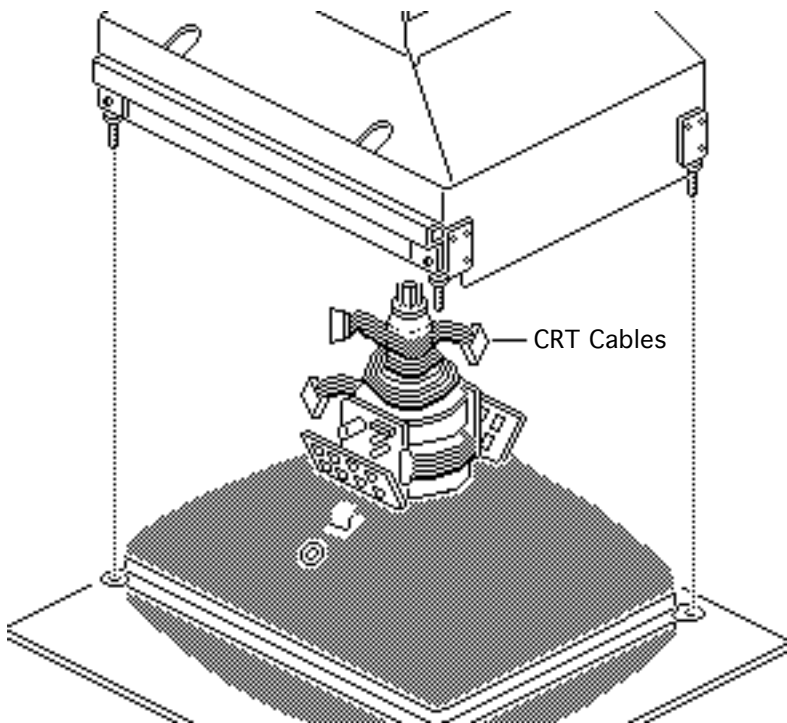

Replacement Note: Before replacing the chassis on the CRT, wrap the three CRT cables around the neck of the CRT. Wrapping the CRT cables in this way guards against trapping the cables beneath the chassis.





Caution: If you are replacing the CRT, make sure the replacement CRT is compatible with the main board. Rev A CRTs require Rev A main boards; Rev B CRTs require Rev B main boards. See “Rev A/B Compatibility” in Additional Procedures.





Additional Procedures

Macintosh 21-inch Color Display



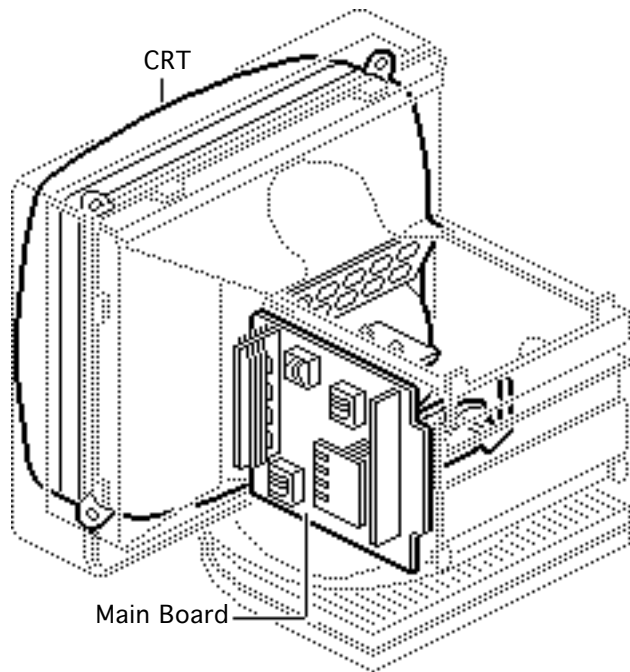

Rev A/B Compatibility

This procedure describes how to identify Rev A and Rev B CRTs and main boards for the Macintosh 21 Inch Color Display. It also explains how to change a Rev B main board to a Rev A main board. (See the Take Apart chapter for complete removal procedures.)

Important: Rev A CRTs require Rev A main boards; Rev B CRTs require Rev B main boards.



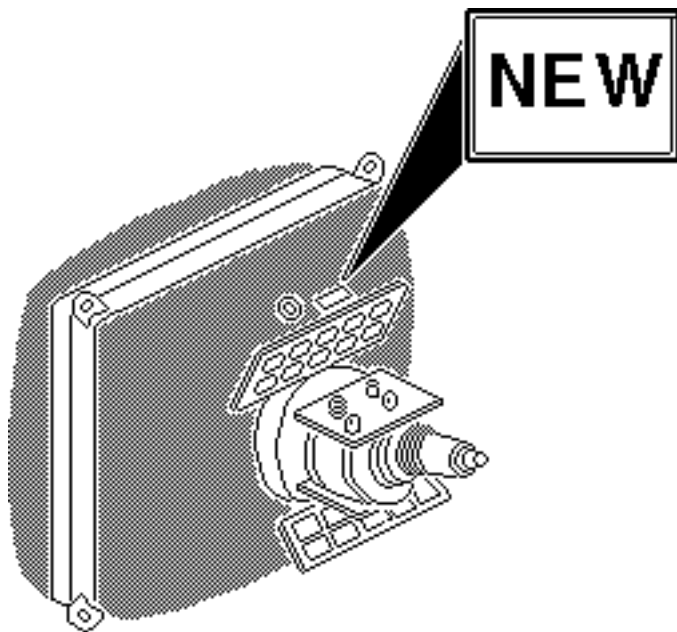

CRT

To differentiate a Rev A CRT from a Rev B CRT, check the CRT near the anode. On Rev B CRTs you'll find a small blue label with the word "NEW" written on it.





Main Board

- 1 To differentiate a Rev A main board from a Rev B main board, check the board for capacitor C153.

The capacitor is mounted on either the component or the solder side of Rev B boards; there is no capacitor C153 on Rev A boards.

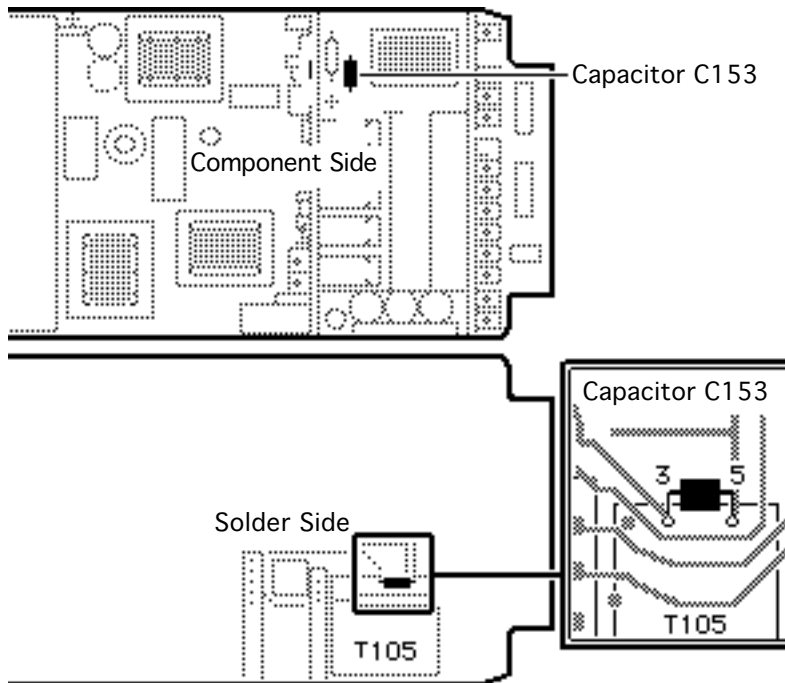

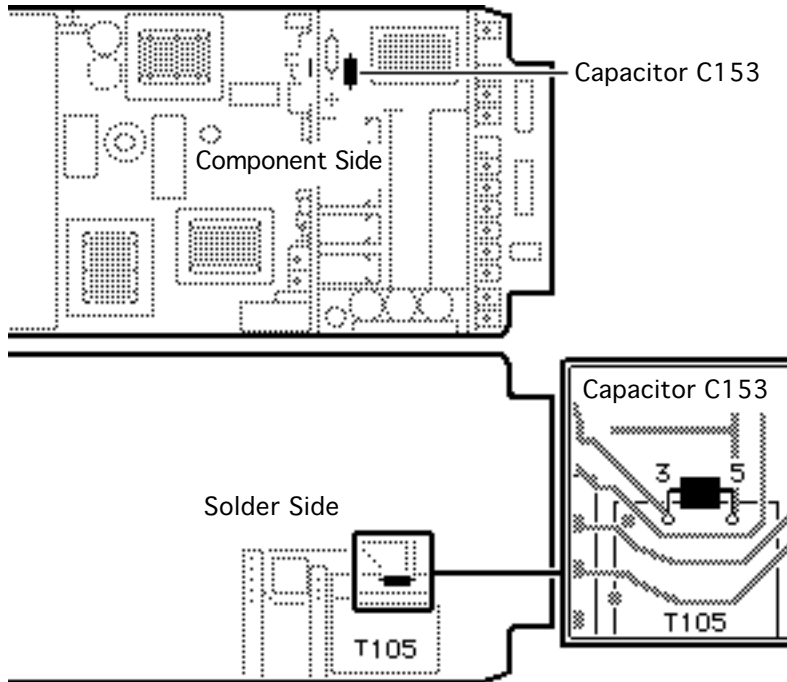

- 2 To change a Rev B main board to a Rev A main board, remove capacitor C153 from the board. (The capacitor may be on either side of the board.)





Adjustments

Macintosh 21 Color Display



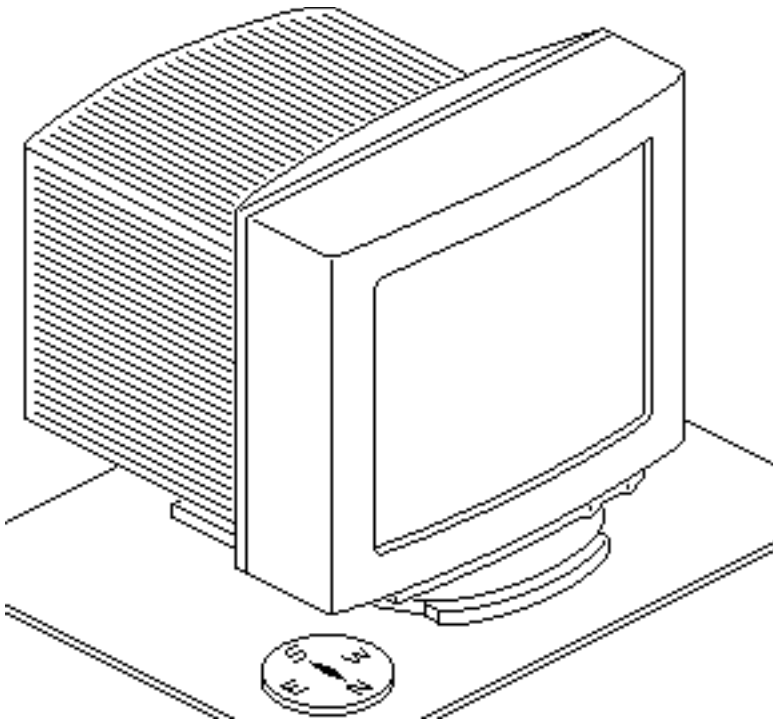

Aligning to Magnetic N/S

Sensitive components inside the display, especially the degaussing circuitry, require aligning the monitor to magnetic north or south before adjusting it.

Note: Keep the monitor at least three feet from any metal objects, such as steel filing cabinets.

- 1 Use a compass to locate magnetic north/south on a protective pad.



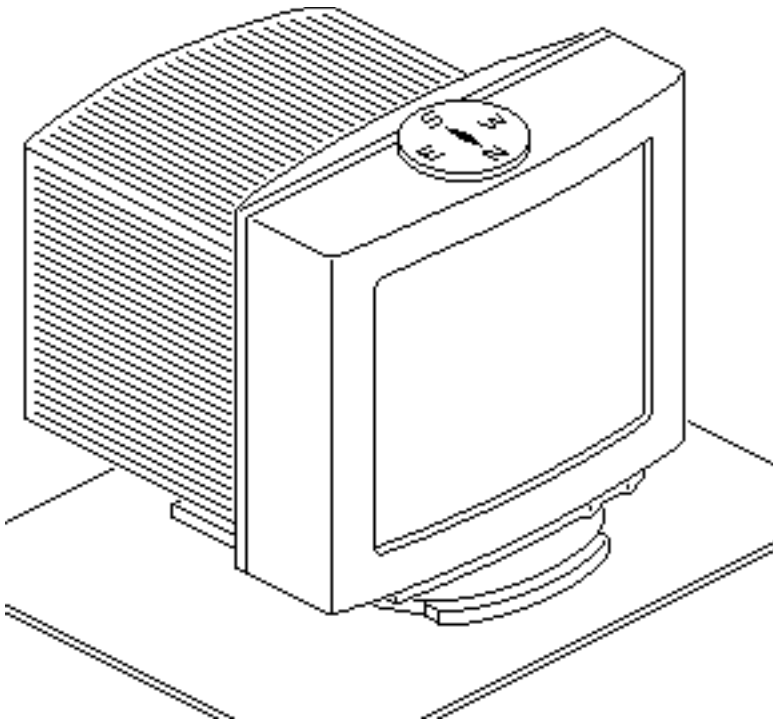

- 2 Place the monitor on the pad in a north/south alignment (with the bezel facing north or south).
- 3 Place the compass on the bezel.
- 4 Swivel the monitor left or right until the compass needle points to North (360 degrees).



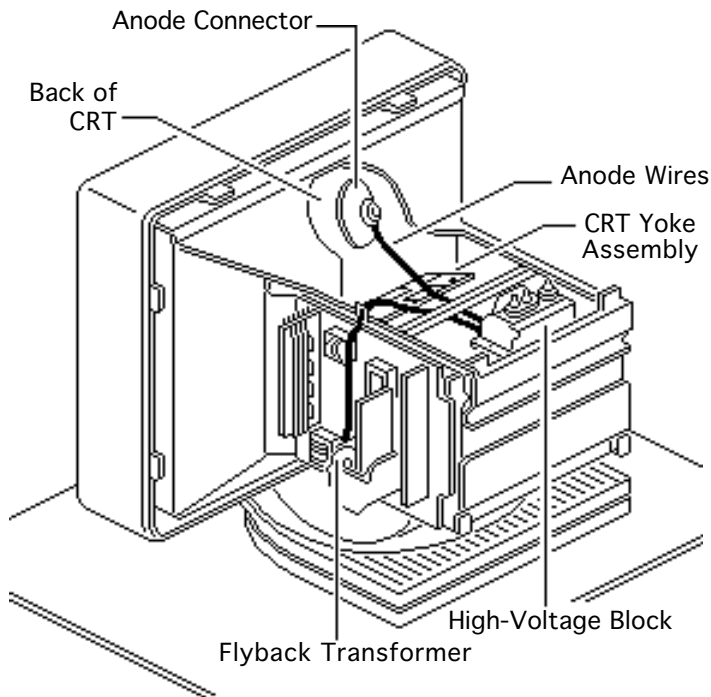

Geometry Setup

Before you begin,

- Remove the rear cover
- Remove the main board access panel
- Turn on monitor power
- Let monitor warm up 15 minutes
- Align monitor to magnetic North/South

⚠ Warning: This product contains very high voltages. When performing live adjustments, be careful not to touch high-voltage components shown at left.





Important: You must perform the geometry setup procedure before performing any other geometry adjustments. After completing the geometry setup, go directly to the geometry adjustments (horizontal and vertical, convergence, or focus) that will fix the customer's monitor problem.



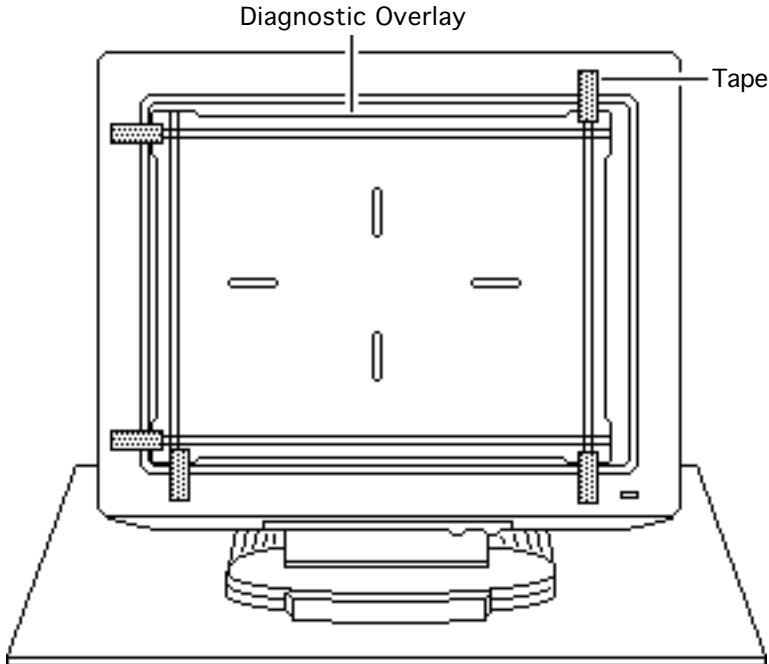

Note: To perform the geometry adjustments, you will need a compass, voltmeter, and diagnostic overlay (P/N 076-0444).

Important: Because of the large size of the CRT, straight lines may appear bent. To avoid distortions, use the diagnostic overlay, take measurements with the same eye, and keep that eye directly above the point being measured.



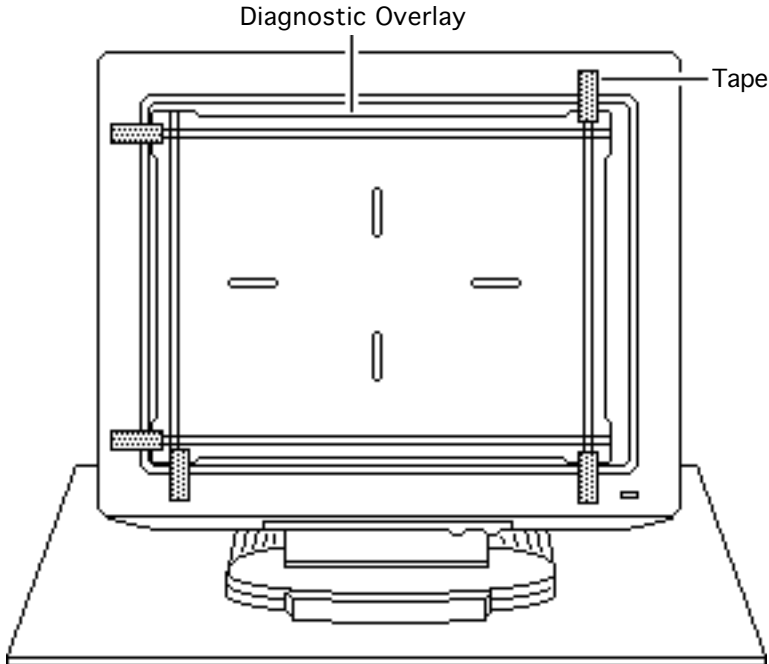

- 1 Tilt the monitor up slightly and place the diagnostic overlay against the inside left and bottom edges of the bezel. Tape the overlay to the bezel.

Note: When using the diagnostic overlay, adjust your head until you see only two etched lines. These lines define the acceptable limits of the raster.



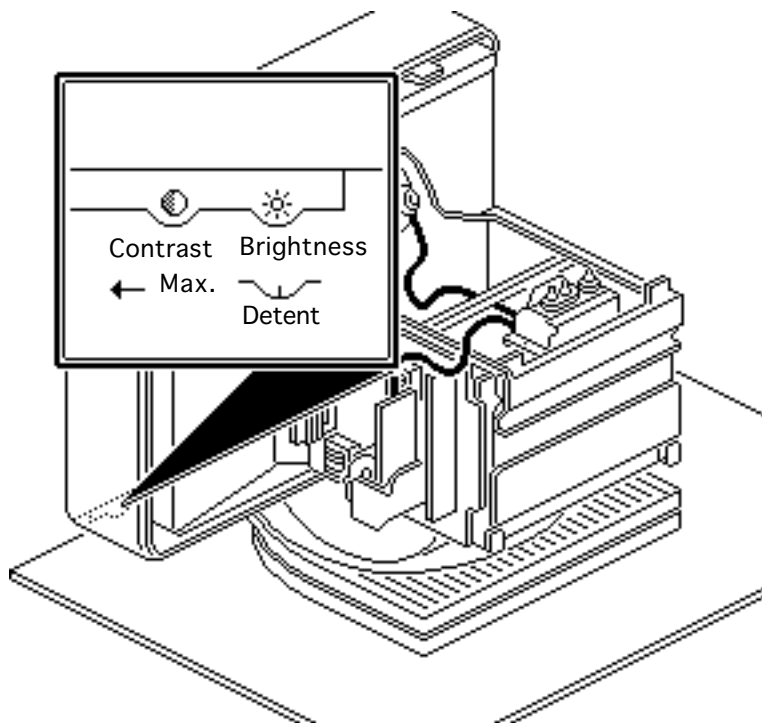

- 2 Set the external brightness control to detent (midrange).
- 3 Turn the contrast control clockwise to maximum contrast.



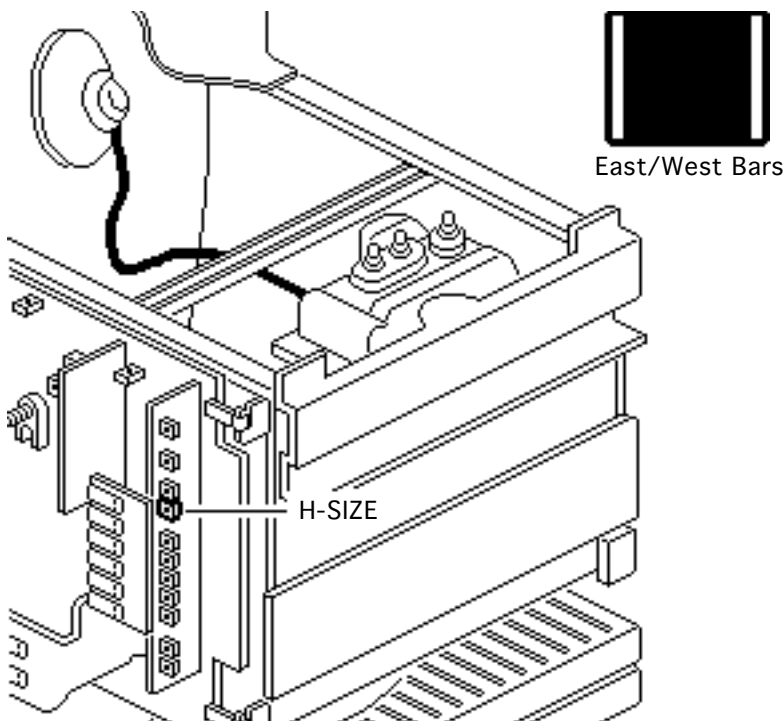

- 4 Use Display Service Utility to display the East/West Bars test pattern.
- 5 **Caution:** Do not apply excessive pressure when adjusting the controls. The controls are mounted perpendicular to the circuit boards and can be broken easily.

Using the insulated screwdriver, adjust the H-SIZE control until the raster is 371 mm (± 3 mm) or 14 11/16 in. ($\pm 1/8$ in.) wide.



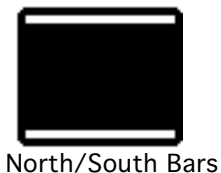
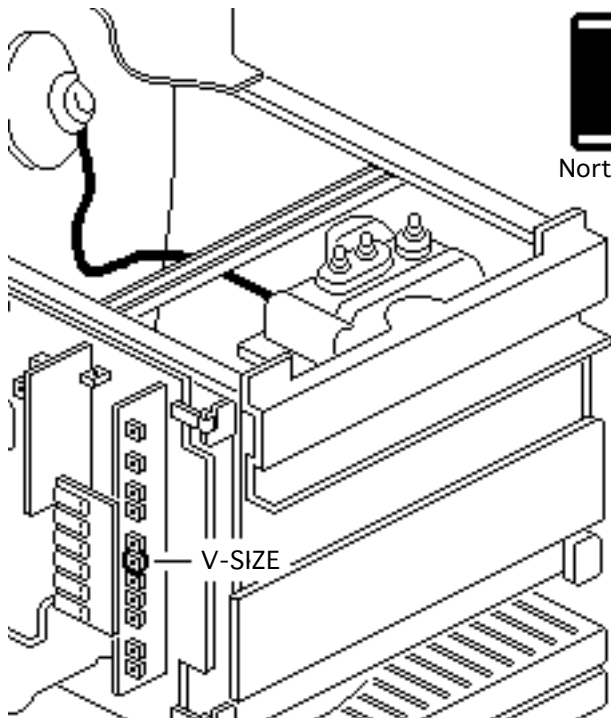

- 6 Using Display Service Utility, display the North/South Bars.
- 7 Using the insulated screwdriver, adjust the V-SIZE control until the raster is 280 mm (± 3 mm) or 11 in. ($\pm 1/8$ in.) high.



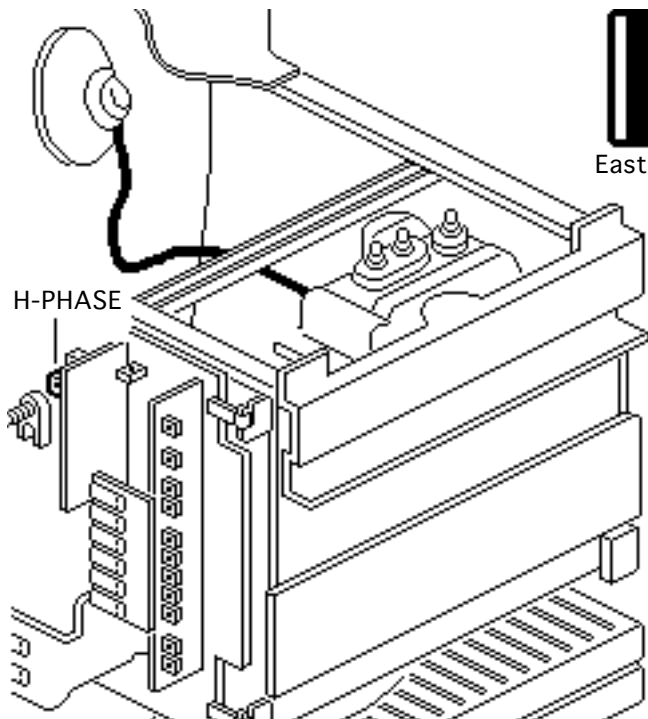

East/West Bars

Horizontal & Vertical

Before you begin, perform the geometry setup procedure.

Important: Perform the horizontal and vertical adjustment steps in the order presented. Perform the step only if you must to attain the correct alignment.

- 1 Using Display Service Utility, display East/West Bars.



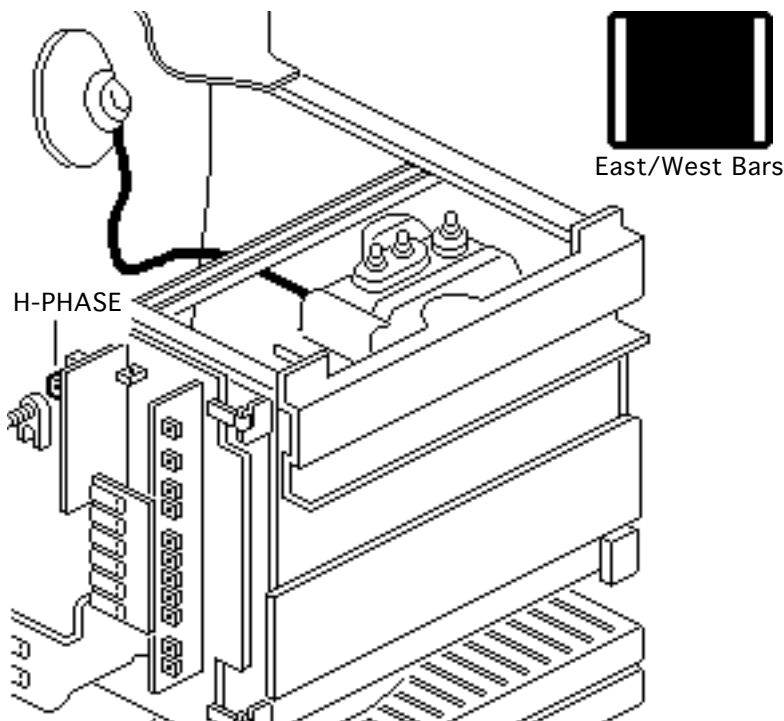

- 2 Using the insulated screwdriver, adjust the H-PHASE control counterclockwise until the left bar wraps at the left edge of the screen. Turn the control back until the right bar stops. Center the control between these points.



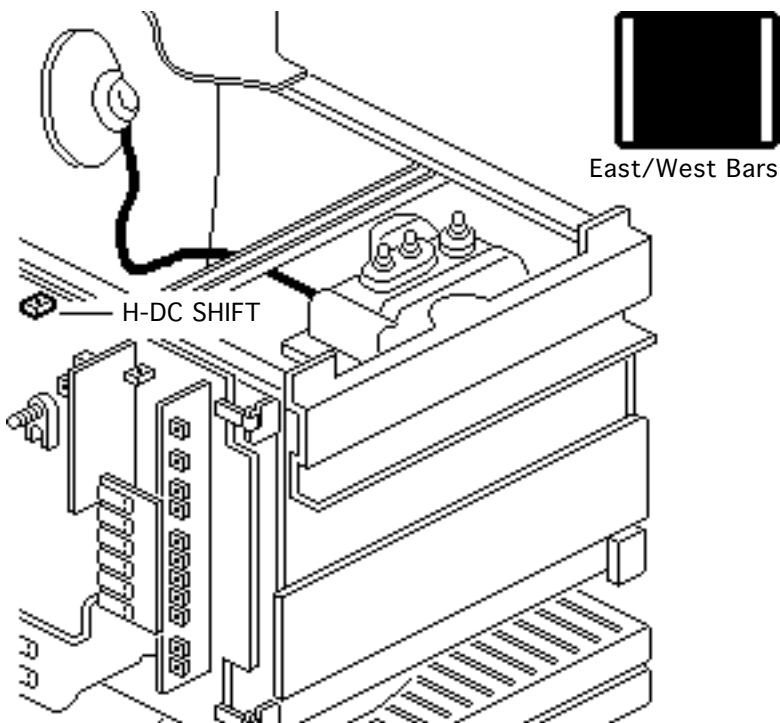

- 3 Using the insulated screwdriver, adjust the H-DC SHIFT control until the left and right bars are centered in the screen.



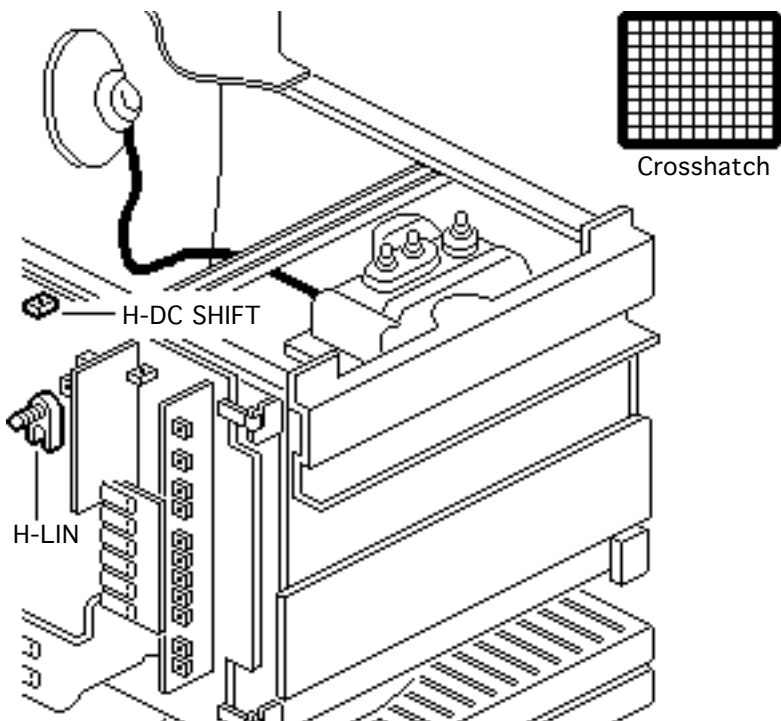

- 4 Using Display Service Utility, display the Crosshatch pattern.
- 5 Using the linearity adjustment tool, adjust the H-LIN control until rectangles on the left and right side of the raster are the same size.
- 6 If necessary, readjust the H-DC SHIFT control centering the pattern in the screen.



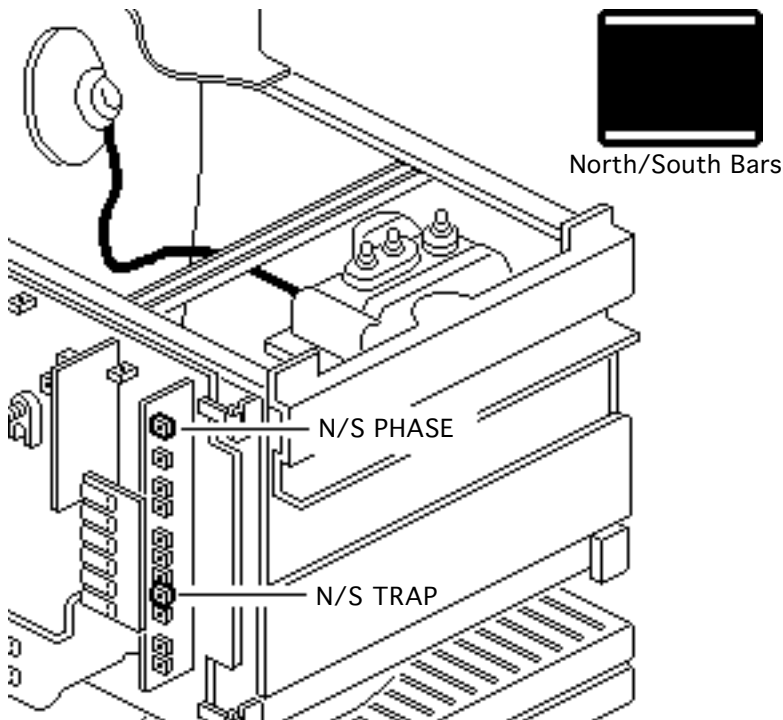

- 7 Using Display Service Utility, display the North/South Bars.
- 8 Using the insulated screwdriver, adjust the N/S PHASE control until the top and bottom horizontal lines are as straight as possible.
- 9 Adjust the N/S TRAP control until the topmost and bottommost lines are parallel. (The N/S TRAP control fine-tunes the N/S PHASE control.)



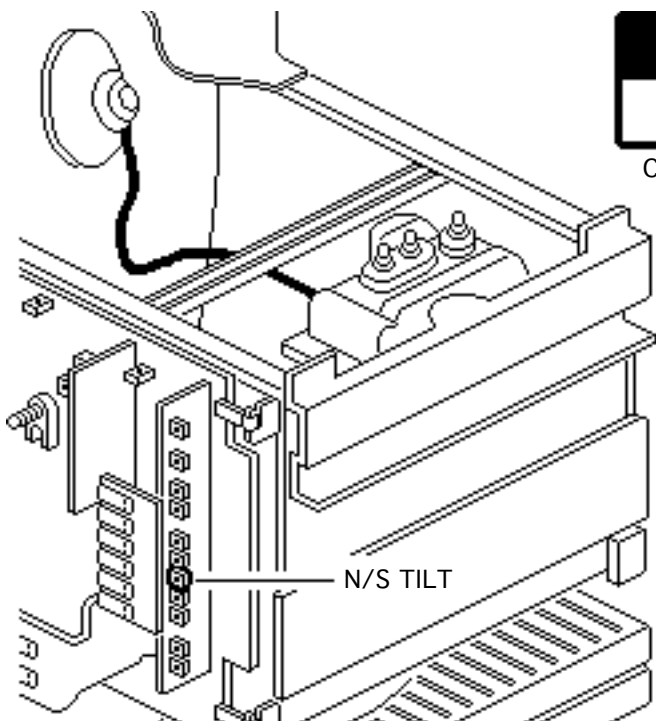

Centerline

- 10 Using Display Service Utility, display the Centerline pattern.
- 11 Using the insulated screwdriver, adjust the N/S TILT control until the centerline is horizontal.



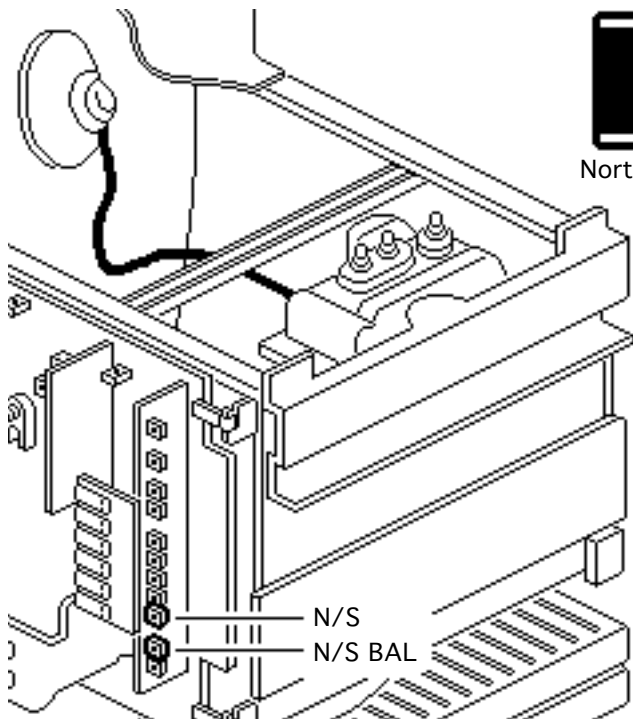

North/South Bars

12 Using Display Service Utility, display the North/South Bars.

Note: In the following steps, strive for the best overall adjustment with both the N/S and N/S BAL controls.

13 Using the insulated screwdriver, adjust the N/S (amplitude) control until the top and bottom horizontal lines are as straight as possible.



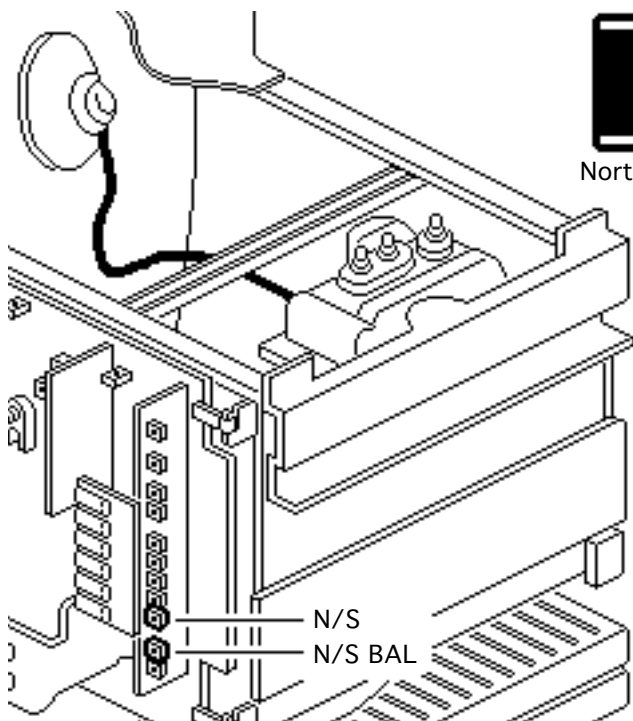

North/South Bars

- 14 Using the insulated screwdriver, adjust the N/S BAL control until the top and bottom horizontal lines are as straight as possible.



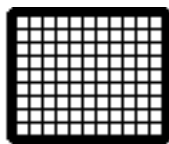
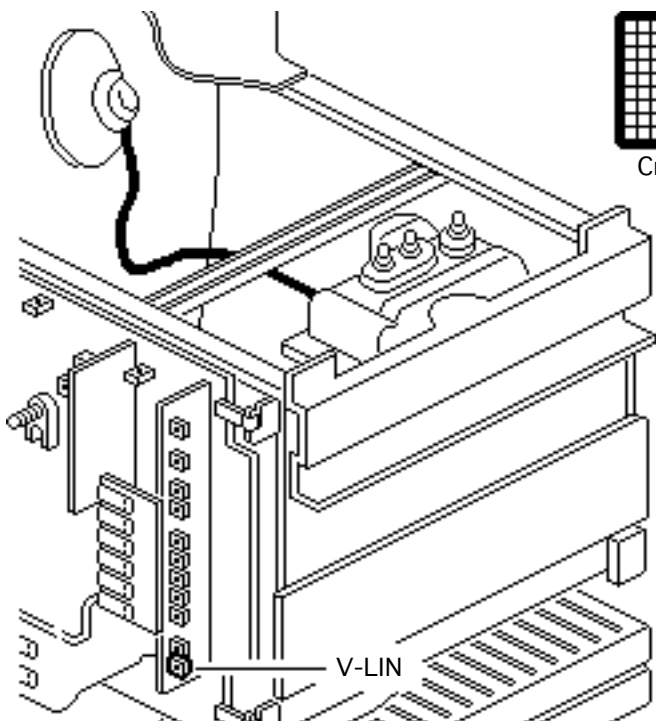

Crosshatch

- 15 Using Display Service Utility, display the Crosshatch pattern.
- 16 Using the insulated screwdriver, adjust the V-LIN control until the height of the rectangles at the top and bottom of the pattern are the same size.



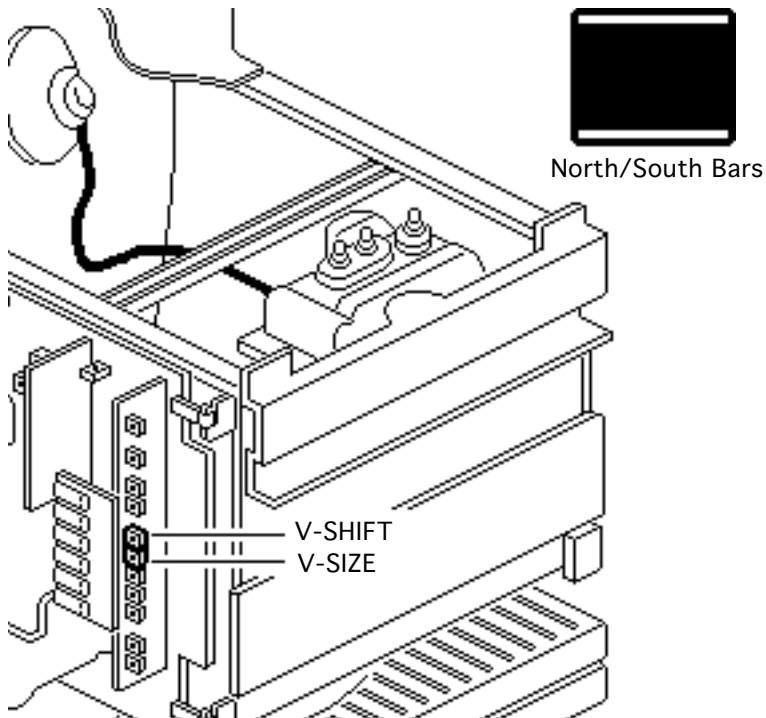

17 Using Display Service Utility, display North/South Bars.

18 Using the insulated screwdriver, adjust the V-SHIFT control until the top and bottom bars are positioned in the vertical center of the screen.

19 Using the insulated screwdriver, adjust the V-SIZE control until the raster is 280 mm (± 3 mm) or 11 in. ($\pm 1/8$ in.) high.



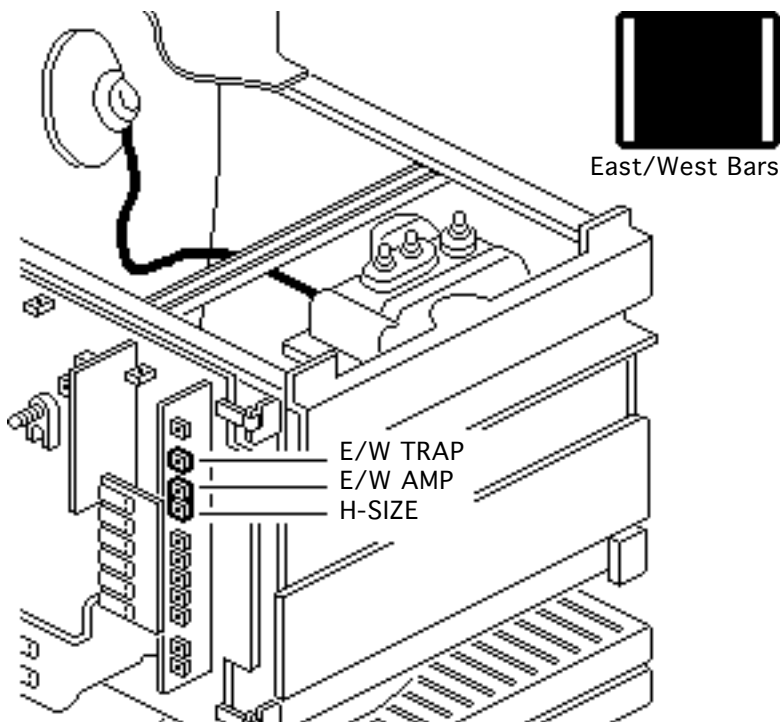

- 20 Using Display Service Utility, display East/ West Bars.
- 21 Using the insulated screwdriver, adjust the E/W TRAP control until the left and right vertical lines are straight.
- 22 Using the insulated screwdriver, adjust the E/W AMP control until the left and right vertical lines are parallel.



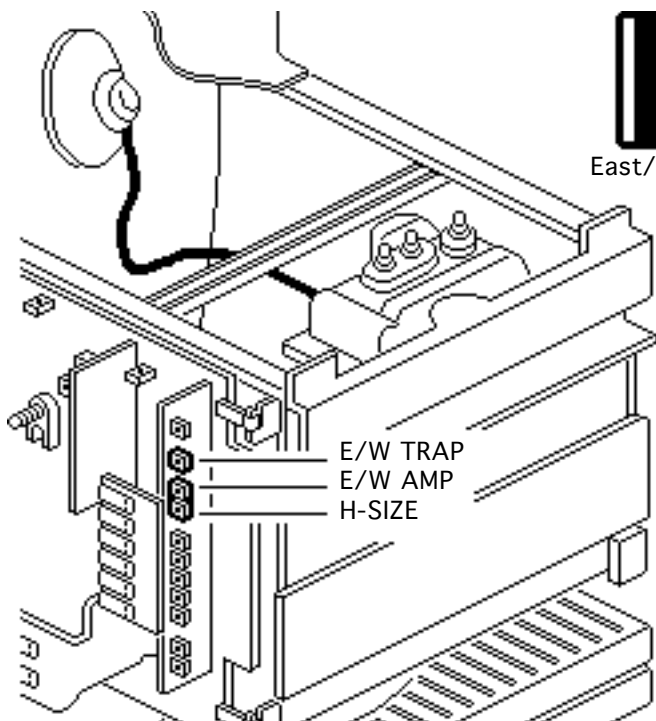

East/West Bars

- 23 Using the insulated screwdriver, adjust the H-SIZE control until the raster is 371 mm (± 3 mm) or 14 11/16 in. ($\pm 1/8$ in.) high.



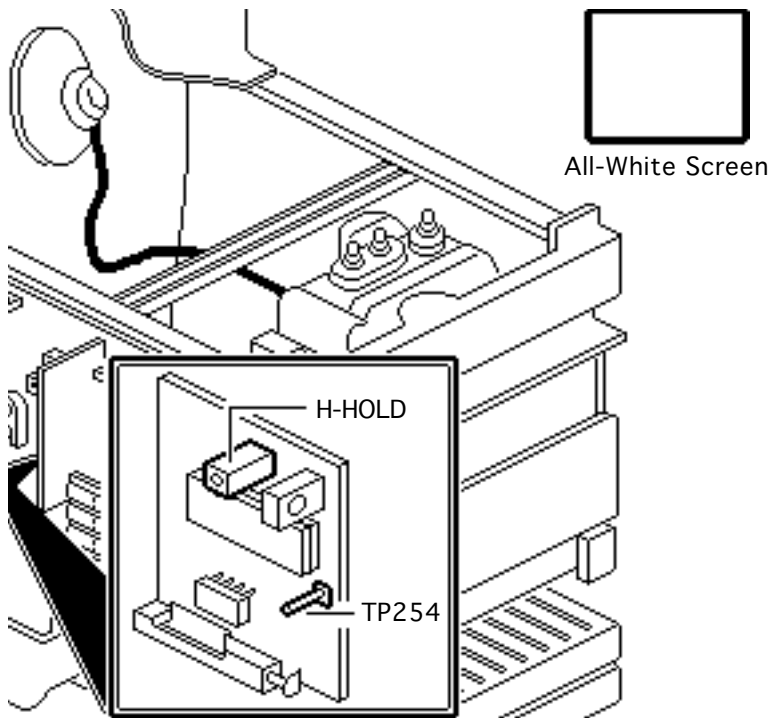

24 Using Display Service Utility, display All-White Screen.

Note: To adjust the H-HOLD control in the next step you must cut a plastic alignment tool to a 3-inch length.

Note: For the next step, make sure the voltmeter is grounded to the monitor chassis and set to the 200 VDC setting.



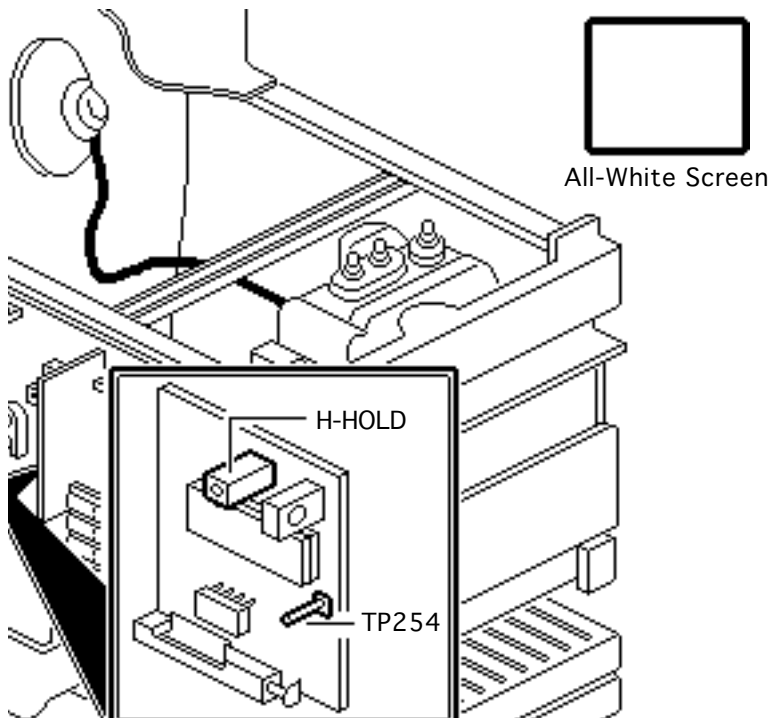

- 25 Using a short insulated screwdriver and a voltmeter, adjust the H-HOLD control until the voltmeter reads 4.1 volts (± 0.2 V) at TP254.
- 26 Remove the diagnostic overlay from the bezel.



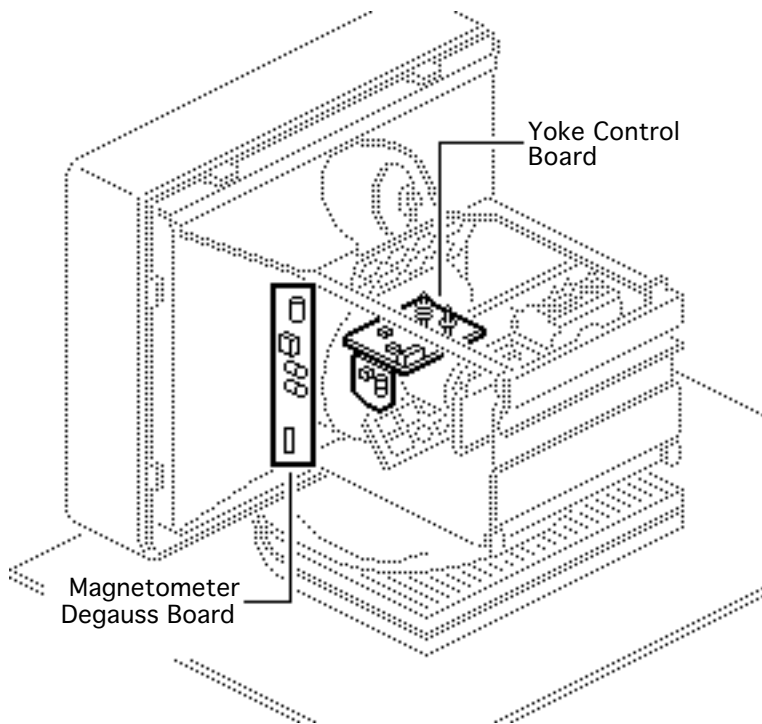

Convergence

Before you begin, perform the geometry setup procedure.

Important: Some misconvergence is normal on large-screen monitors. The convergence adjustments on the yoke of the CRT are factory adjusted and you should never have to readjust them.

Note: Before attempting the entire convergence procedure, refer to



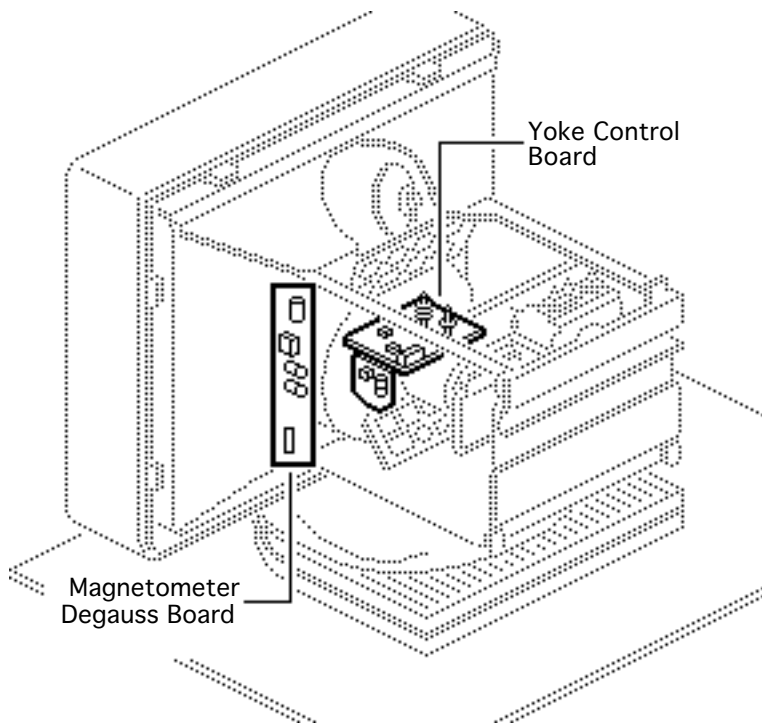

“Convergence Alignment” symptom charts in the Troubleshooting chapter and try the control that best corrects the misconvergence problem.

Note: You may not be able to precisely align convergence at every point on the screen, but strive for the best overall alignment with each convergence control. Locate the convergence controls on the yoke control board and the magnetometer degauss board.



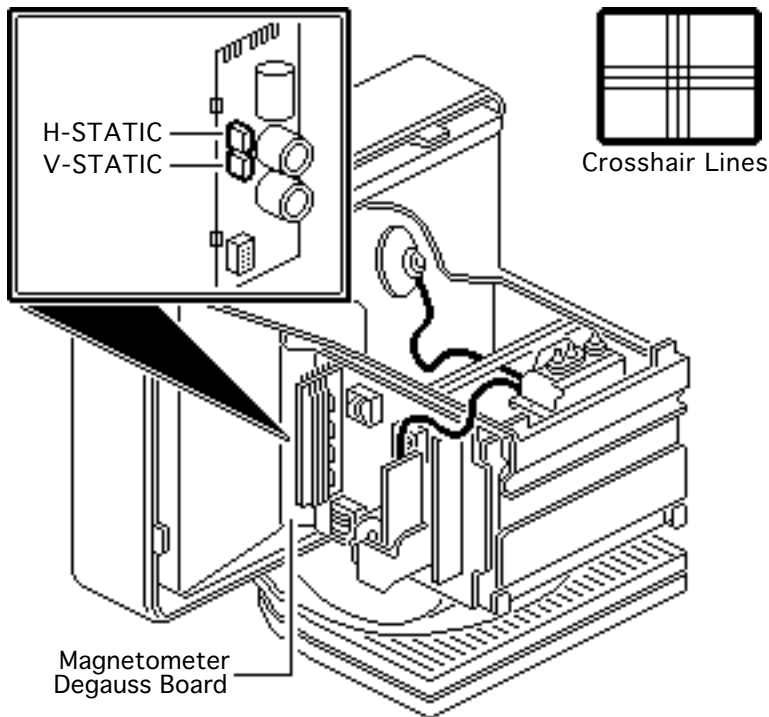

- 1 Using Display Service Utility, display Crosshair Lines.
- 2 Using the insulated screwdriver, adjust the following controls on the magnetometer degauss board:
 - H-STATIC control to align the red and blue vertical lines at midscreen.
 - V-STATIC control to align the red and blue horizontal lines at midscreen.



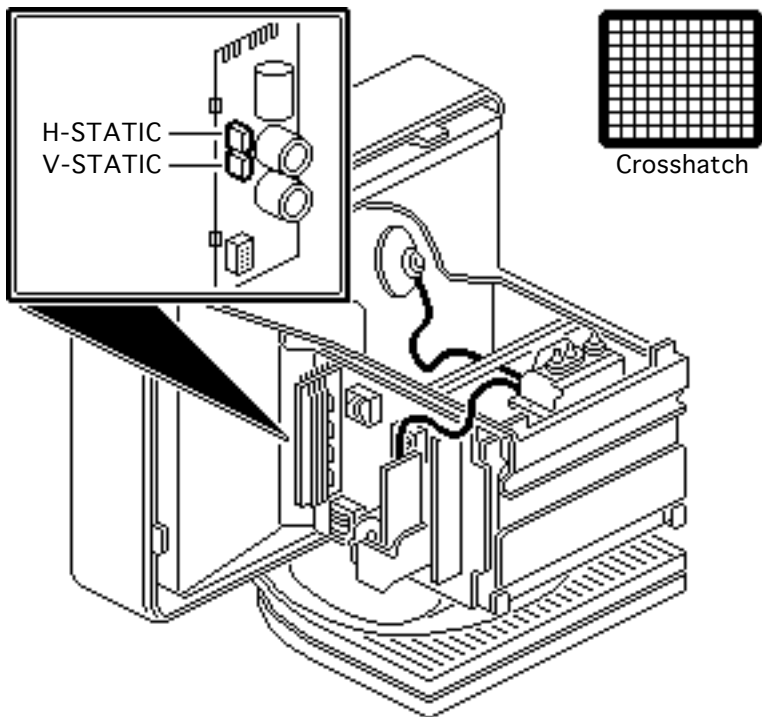

- 3 Using Display Service Utility, display Crosshatch.
- 4 Recheck screen convergence. If convergence is OK, stop here. (The H-STATIC and V-STATIC controls correct many problems).





- 5 **⚠ Warning:** When removing access panels with power on, keep in mind that serious injury could result if you touch any of the high-voltage components.

If convergence is not OK, remove the CRT access cover (see Take Apart) and continue the procedure.



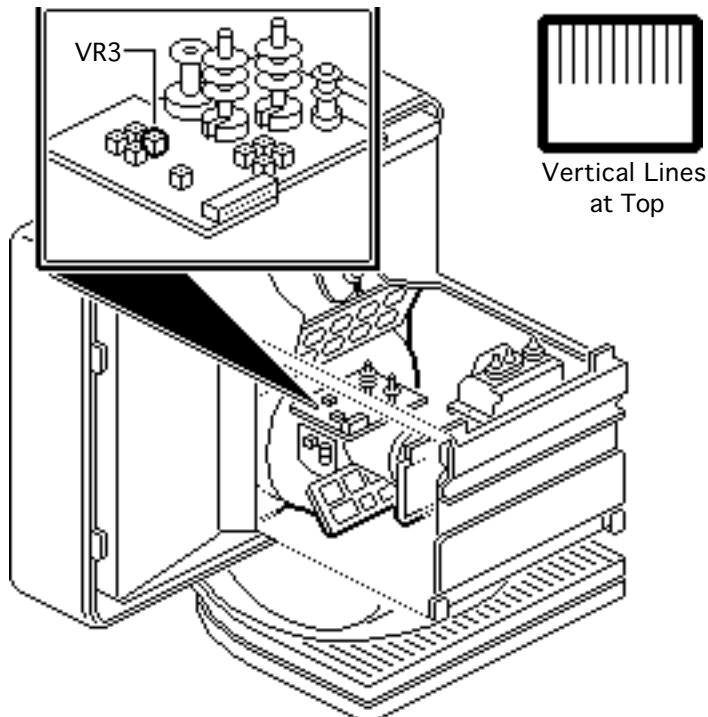

- 6 Using Display Service Utility, display Vertical Lines at Top pattern.
- 7 Using the insulated screwdriver and the VR3 yoke control, align the vertical lines in the top 2 inches (50 mm).



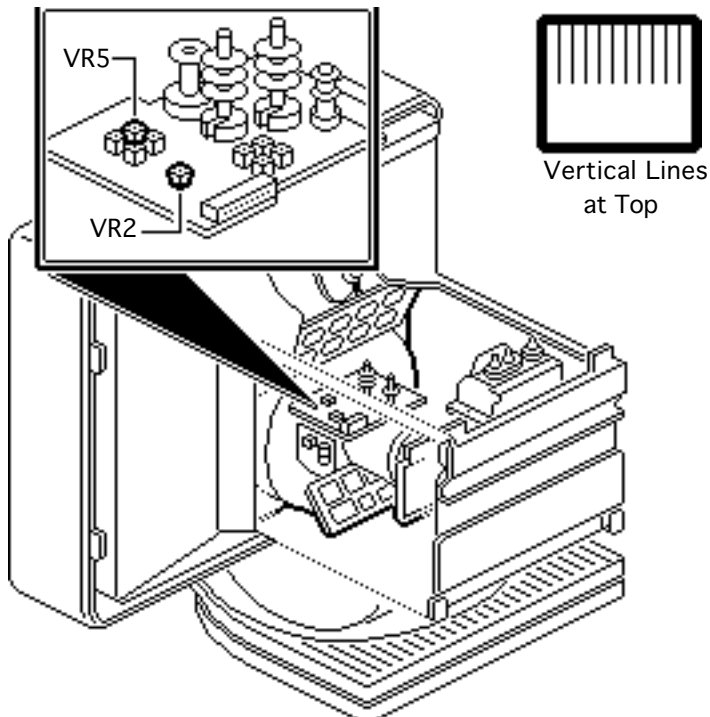

- 8 Using the insulated screwdriver and the VR2 yoke control, align the vertical lines in the top 1/4 inch (5 mm).
- 9 Using the insulated screwdriver and the VR5 yoke control, align the vertical lines in the upper 4 inches (100 mm).





Note: The AMP-T control adjusts the tops of the red and blue vertical lines equally; the TILT-T control adjusts the vertical lines at the top left side of the screen more than at the top right. You may need to use the TILT-T control to misalign the left and right vertical lines equally, and then return to the AMP-T control to align them.



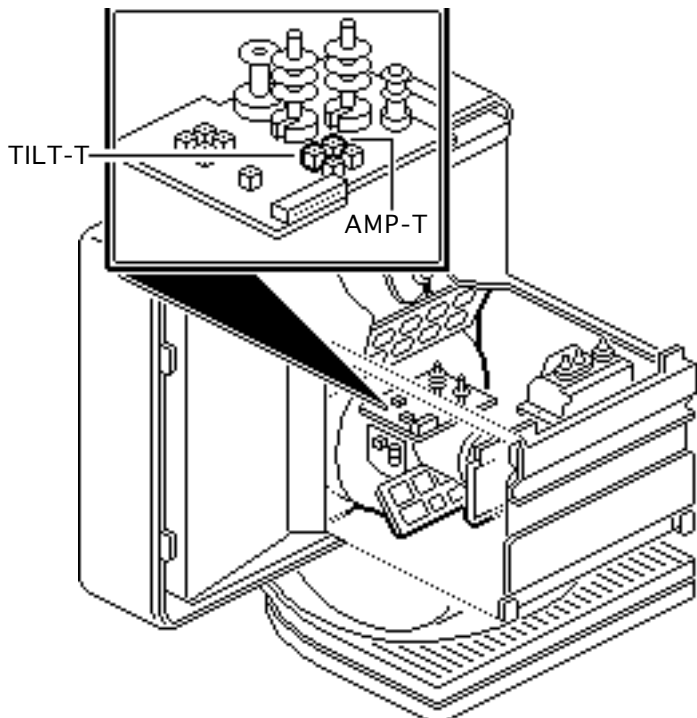

- 10 Using the insulated screwdriver and the AMP-T yoke control, align the top 2 inches (50 mm) of the left and right vertical lines.
- 11 Using the insulated screwdriver and the TILT-T yoke control, adjust the tops of the left and right vertical lines. If necessary, return to the AMP-T control.



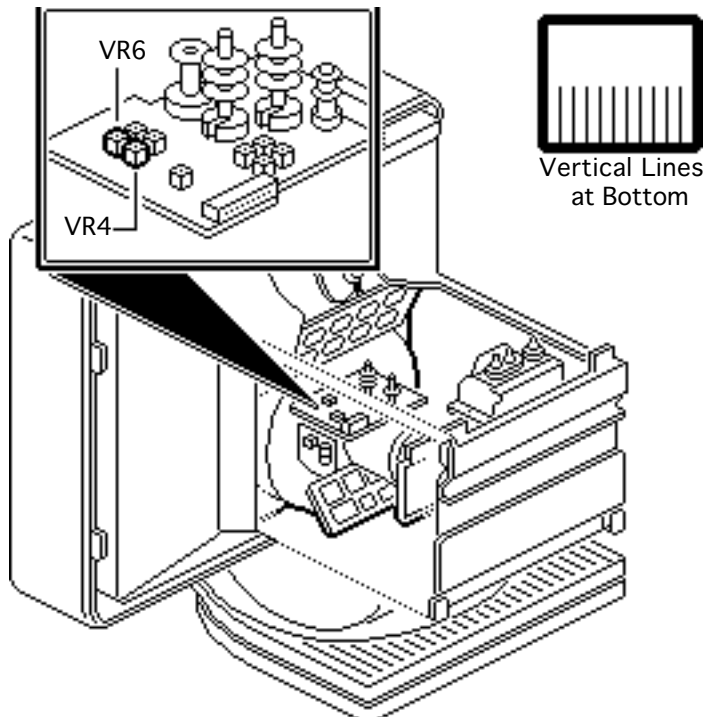

- 12 Using Display Service Utility, display Vertical Lines at Bottom pattern.
- 13 Using the insulated screwdriver and the VR4 yoke control, align the vertical lines in the bottom 2 inches (50 mm).
- 14 Using the insulated screwdriver and the VR6 yoke control, align the vertical lines in the bottom 4 inches (100 mm).





Note: The AMP-B control affects the bottom of the red and blue vertical lines equally; the TILT-B control affects the vertical lines at the bottom left side of the screen more than at the bottom right. You may need to use the TILT-B control to misalign the left and right vertical lines equally, and the AMP-B control to align them.



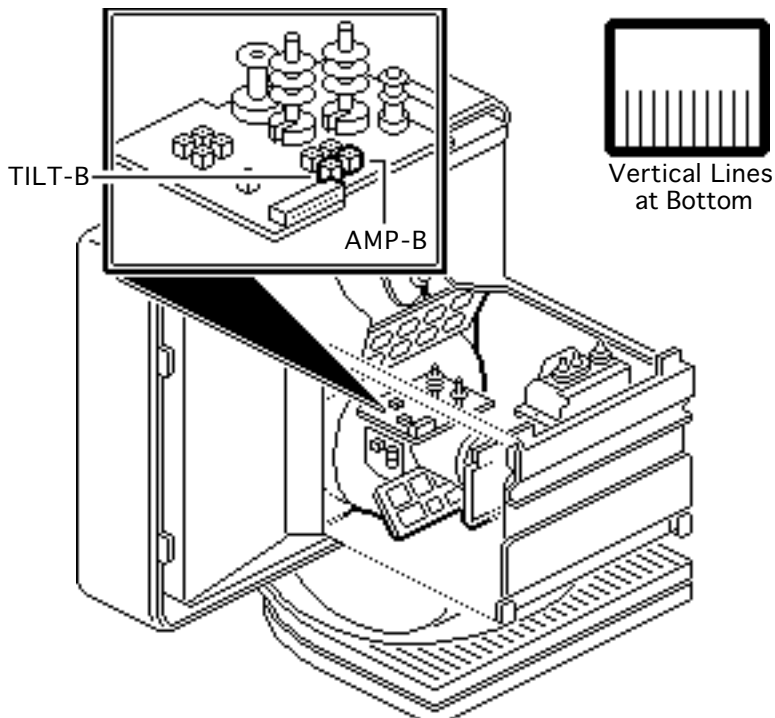

15 Using the insulated screwdriver and the AMP-B yoke control, align the bottom 2 inches (50 mm) of the vertical lines.

16 Using the insulated screwdriver and the TILT-B yoke control, adjust the bottoms of the left and right vertical lines. If necessary, return to the AMP-B control.



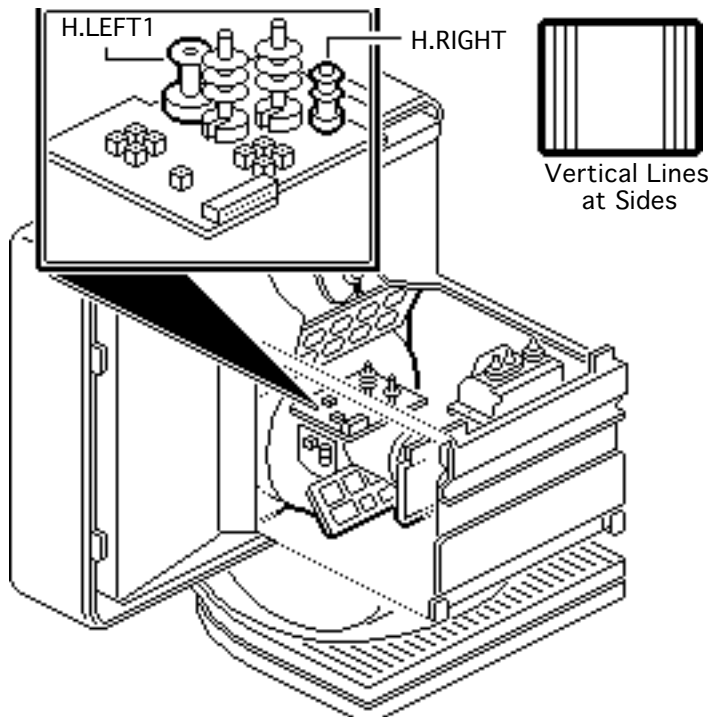

17 Using Display Service Utility, display Vertical Lines at Sides pattern.

Note: The H.RIGHT control affects the vertical lines at the left and right sides of the screen equally; the H.LEFT1 control affects the vertical lines at the left side of the screen more than at the right. You may need to use the H.LEFT1 control to misalign the left and right vertical lines equally, and the H.RIGHT control to align them.



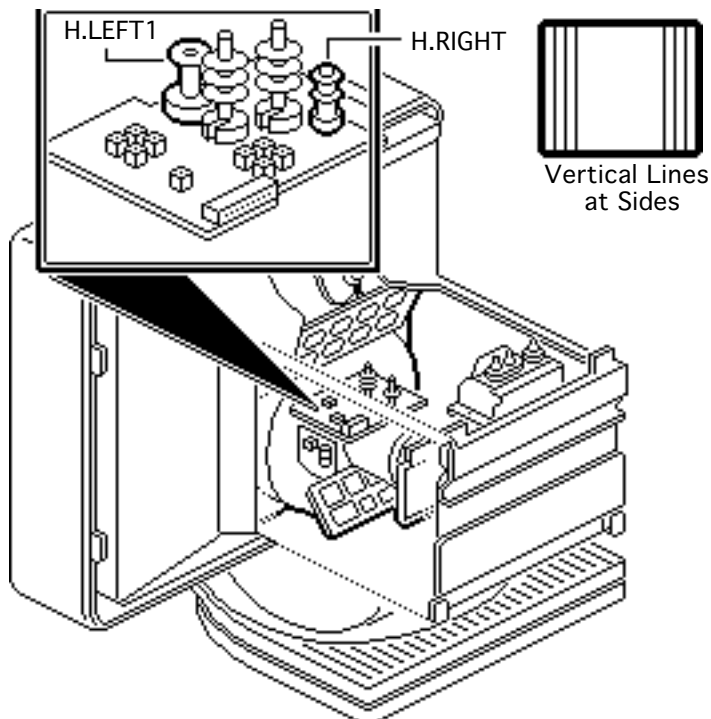

- 18 Using the hex-head adjustment tool and the H.RIGHT yoke control, align the vertical lines at the left and right sides of the screen.
- 19 Using the insulated screwdriver and the H.LEFT1 yoke control, adjust the vertical lines at the left and right sides of the screen. If necessary, return to the H.RIGHT control.



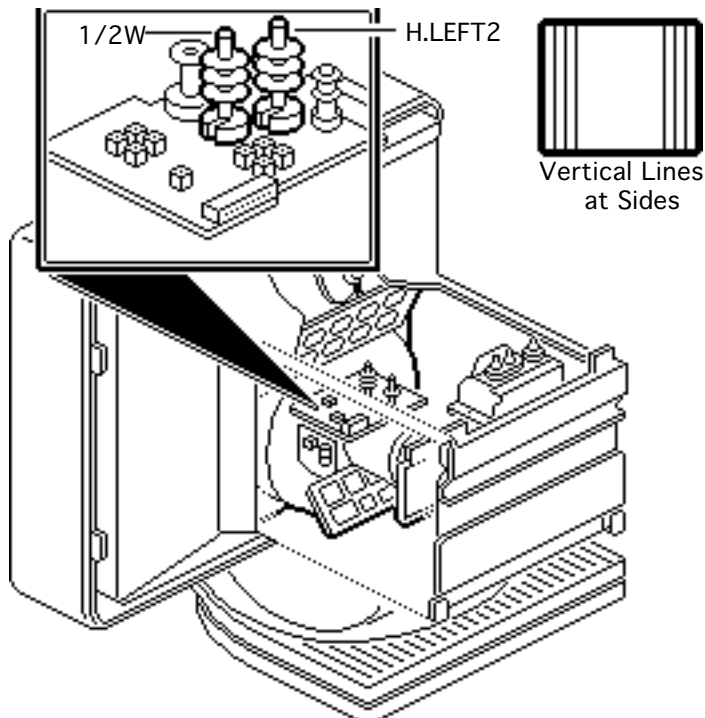

- 20 Using the hex-head adjustment tool and the H.LEFT2 yoke control, align the vertical lines in an area 3–5 inches (75–125 mm) from the left and right edges of the screen.
- 21 Using the insulated screwdriver and the 1/2W yoke control, align the vertical lines on the left third of the screen.



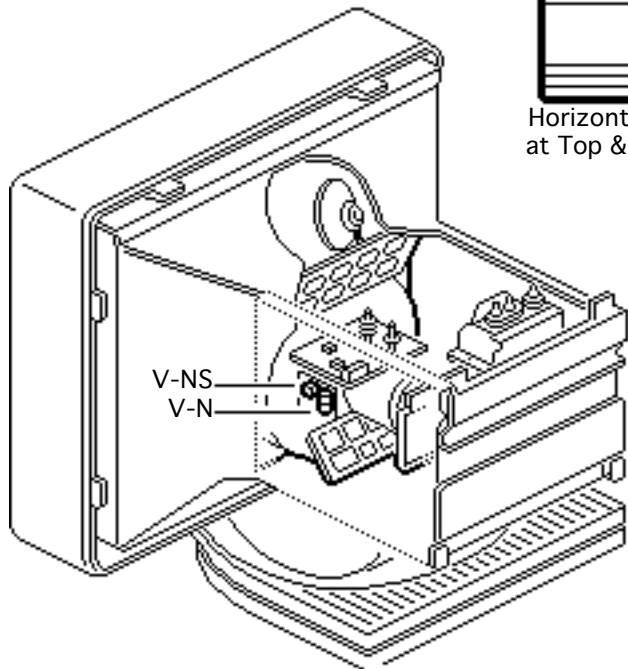

Horizontal Lines
at Top & Bottom

22 Using Display Service Utility, display Horizontal Lines at Top & Bottom pattern.

Note: The V-NS control affects the red and blue horizontal lines at the top and bottom of the screen equally; the V-N control affects the horizontal lines at the top of the screen more than at the bottom. You may need to use the V-N control to misalign the top and bottom horizontal lines equally, and the V-NS



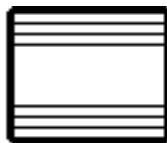
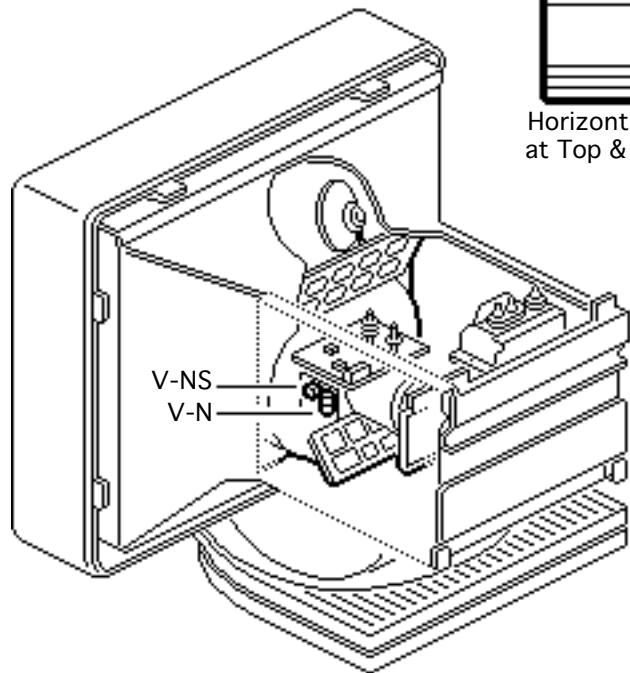

Horizontal Lines
at Top & Bottom

control to align them.

23 Using the insulated screwdriver and the V-NS yoke control, align the horizontal lines at the top and bottom of the screen.

24 Using the insulated screwdriver and the V-N yoke control, adjust the horizontal lines at the top and bottom of the screen. If necessary, return to the V-NS control.



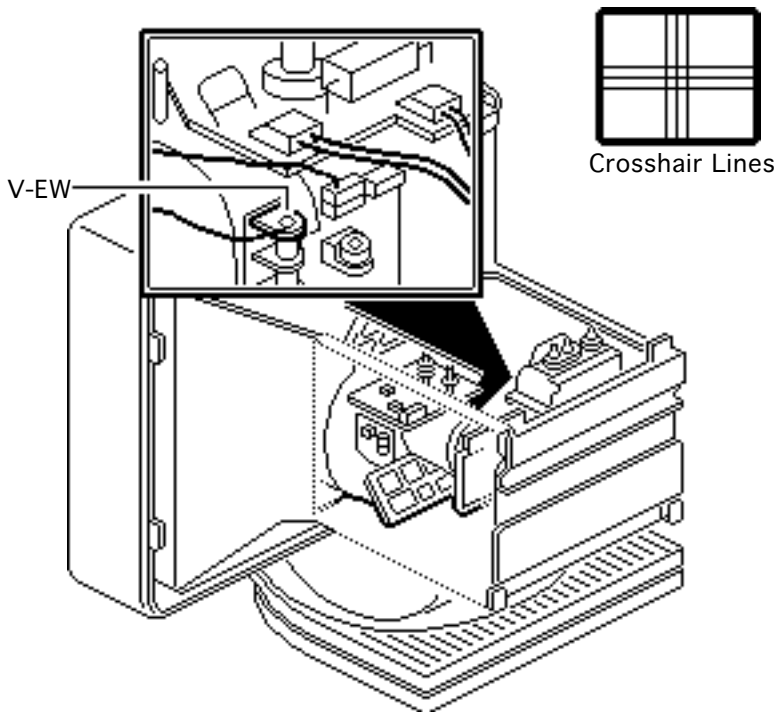

25 Using Display Service Utility, display Crosshair Lines.

26 **Note:** The V-EW control rotates the red and blue guns around an imaginary axis in the center of the screen.

Using the hex-head adjustment tool and the V-EW yoke control, align the centermost horizontal lines at the left and right edges of the screen.



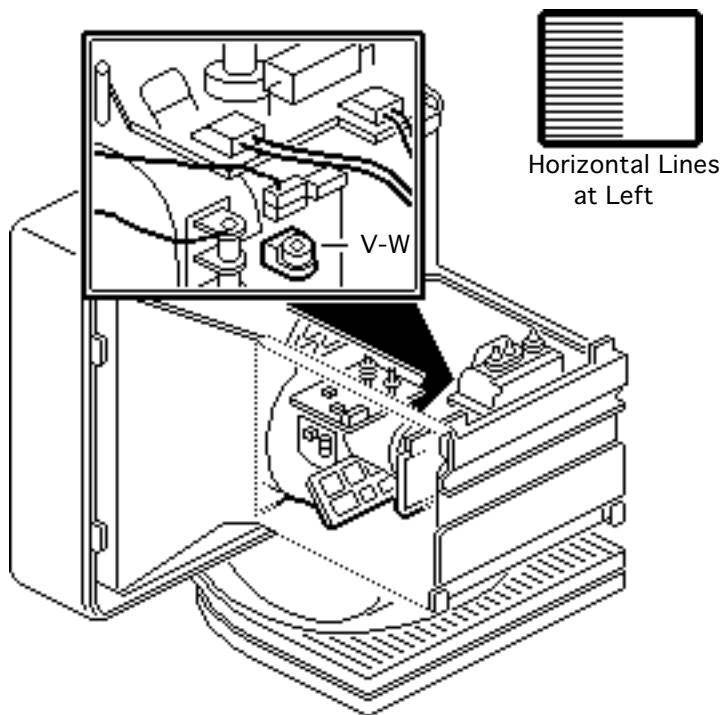

- 27 Using Display Service Utility, display Horizontal Lines at Left pattern.
- 28 Using the insulated screwdriver and the V-W yoke control, align the horizontal lines at the left edge of the centerline.



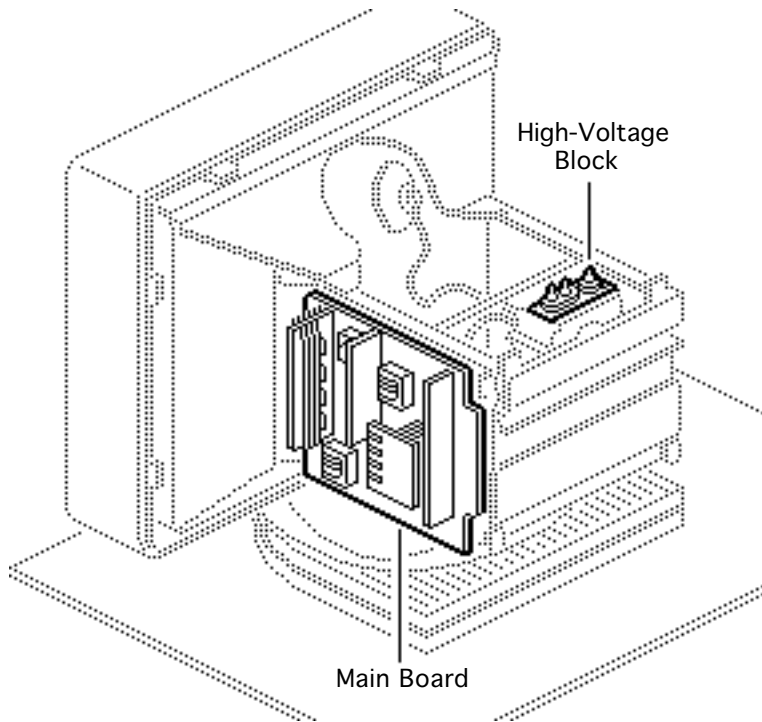

Focus

Before you begin,

- Perform the geometry setup procedure
- Remove the CRT access cover

⚠ Warning: When removing the access panels with power on, keep in mind that serious injury could result if you touch any of the high-voltage components.

Note: The focus controls are located on the main board and the high-voltage block.



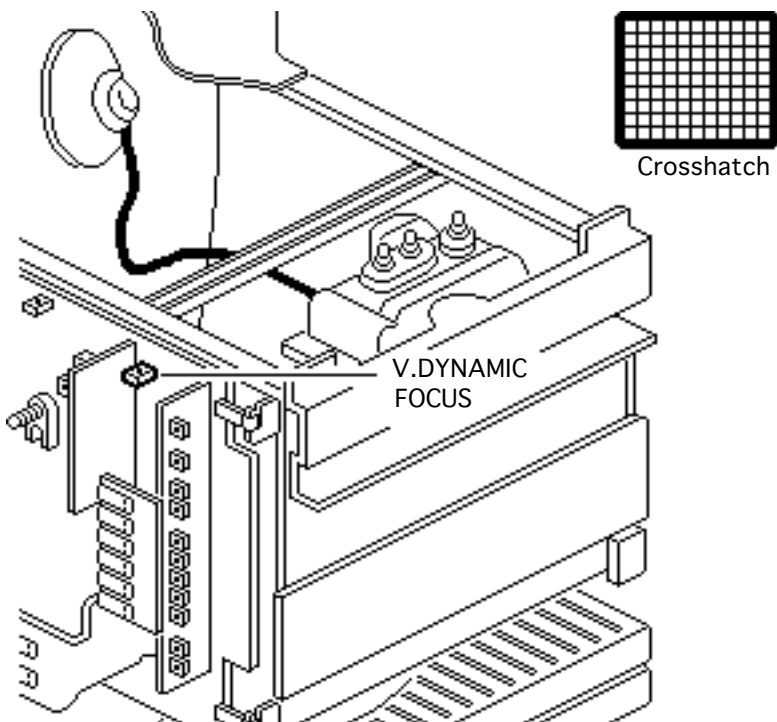

- 1 Using Display Service Utility, display Crosshatch.
- 2 Using the insulated screwdriver, turn the V.DYNAMIC FOCUS (R155) control on the main board clockwise to its limit.



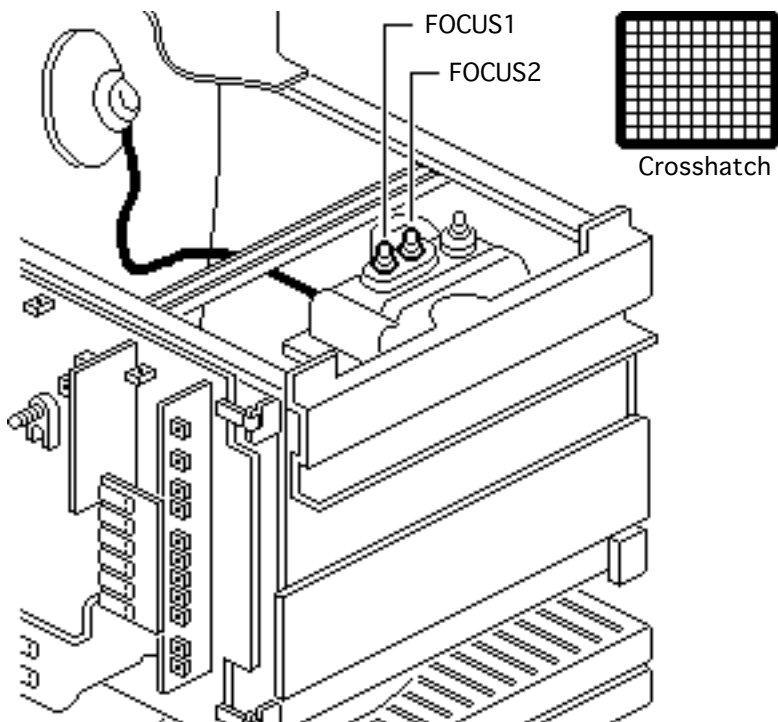

- 3 Using the insulated screwdriver, adjust the FOCUS2 control on the high-voltage block until the center vertical line is as small as possible.
- 4 Using the insulated screwdriver, adjust the FOCUS1 control on the high-voltage block until the center horizontal line is as small as possible.



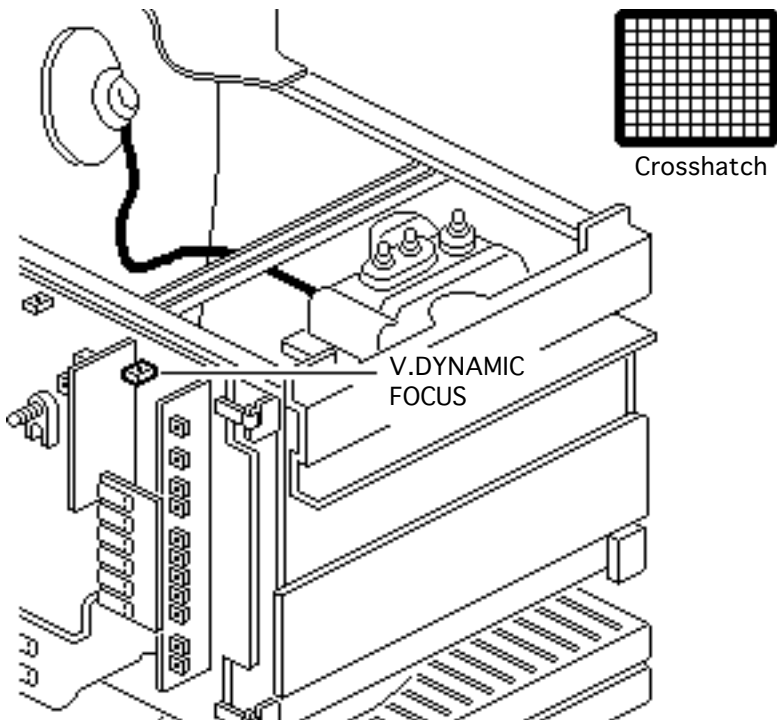

- 5 Check whether the horizontal lines at the top and bottom of the screen are precisely focused. If not, back off (turn counterclockwise) the V.DYNAMIC FOCUS (R155) control until the horizontal lines are as small as possible.



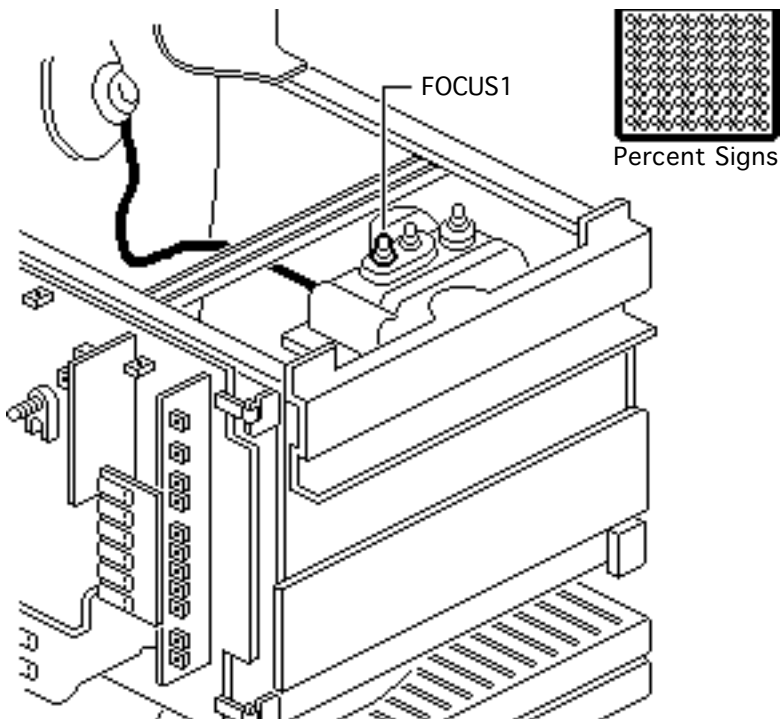

- 6 Using Display Service Utility, display focus adjustment pattern, Percent Signs.
- 7 Using the insulated screwdriver, adjust the FOCUS1 control on the high-voltage block for best overall focus.



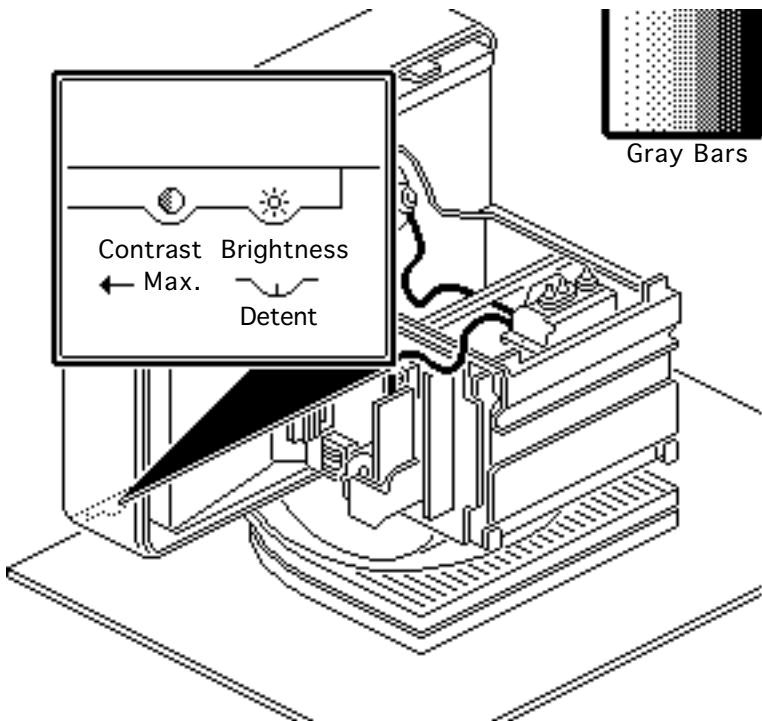

Checking Display Video

Before you begin,

- Turn on monitor power
- Let monitor warm up 15 minutes
- Align monitor to magnetic North/South

Important: Use the following procedure to determine whether the color quality of the customer's display is acceptable. Perform video adjustments only if the color quality is unacceptable.



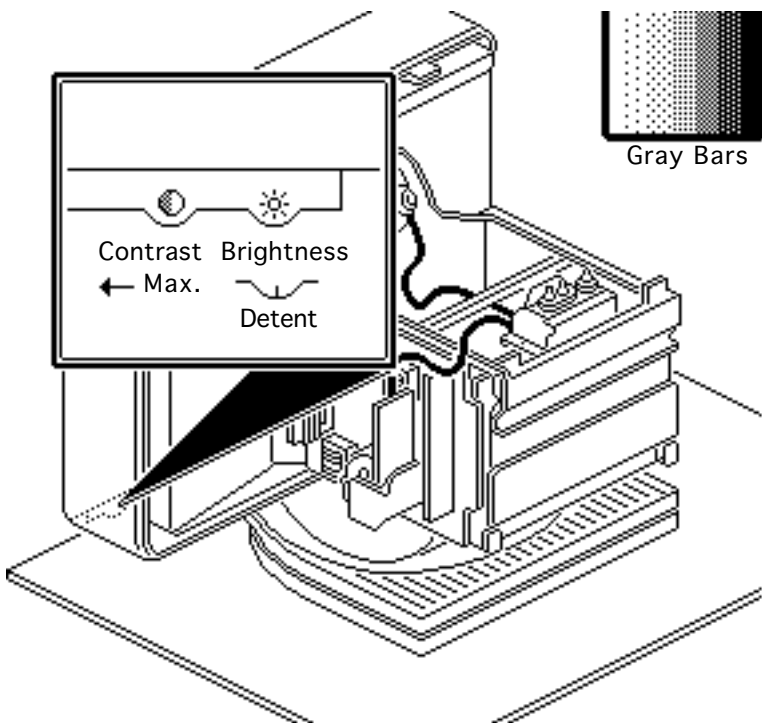

- 1 Using Display Service Utility, display Gray Bars.
- 2 Set the external brightness control to its center detent position and the external contrast control to maximum contrast (turn fully clockwise).



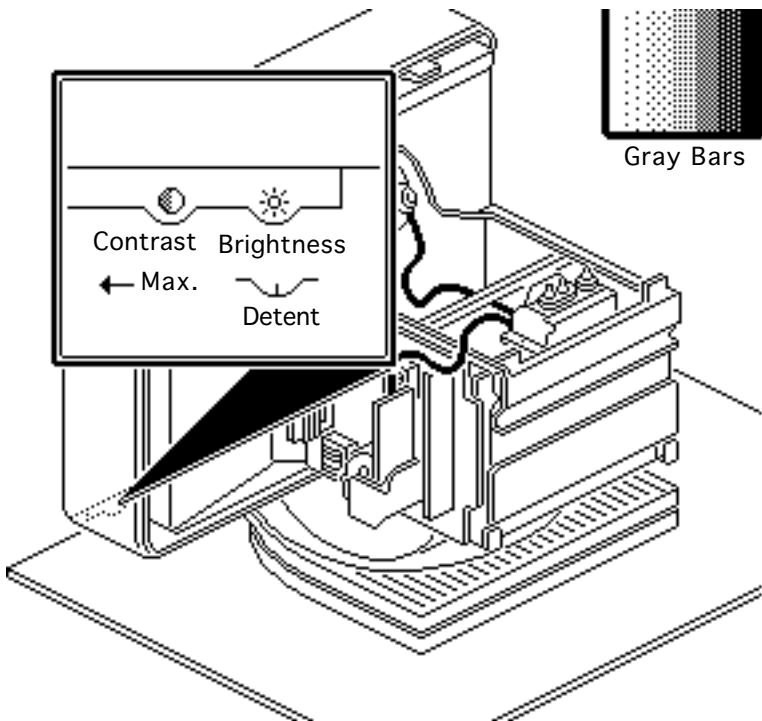

- 3 Check that
- There is no colored tint in the gray bars.
 - The brightest bar measures 27 foot lamberts (± 3 foot lamberts), which on the light meter is
 - Model R77: between 21 and 22 on the bottom scale
 - Model L-248: low end of the 10 scale
 - Model 246: 21.5 on the red scale
 - The darkest three bars are respectively black, barely





distinguishable from the black bar, and dark gray.

- 4 If these conditions are not met, perform the video adjustments procedure.



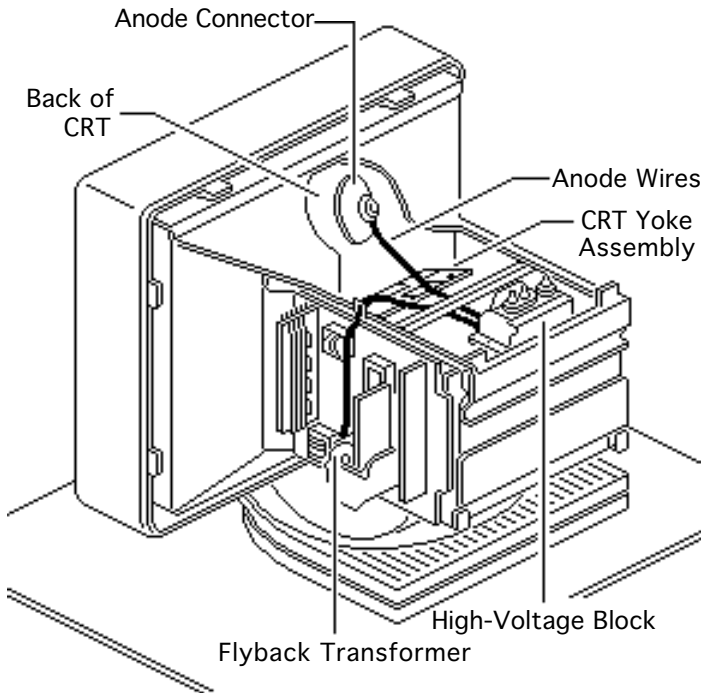

Video

Before you begin,

- Remove the rear cover
- Remove the CRT and video board access panels
- Turn on monitor power
- Let monitor warm up 15 minutes
- Align monitor to magnetic North/South

Important: Perform the video adjustments only if the color quality is unacceptable. Refer to the preceding topic, “Checking Display Video.”



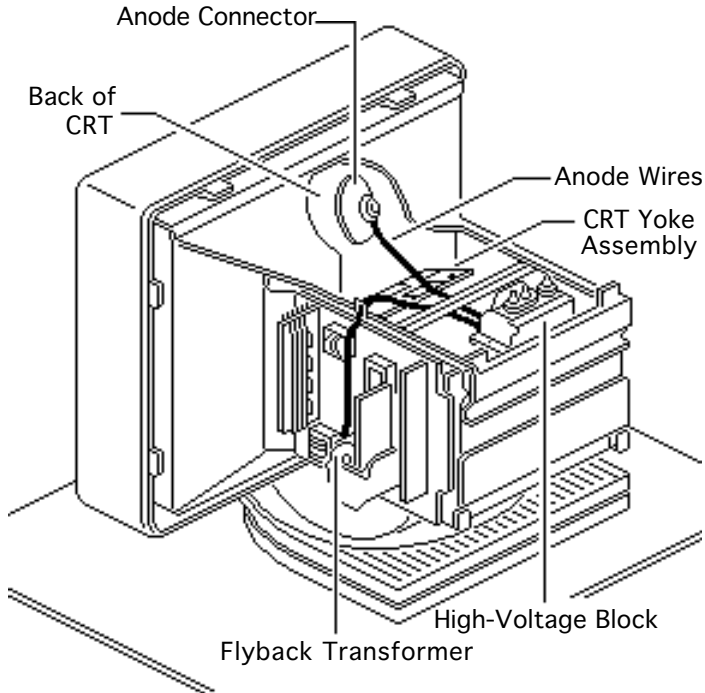

⚠ Warning: This product contains very high voltages. When performing live adjustments, be careful not to touch high-voltage components shown at left.



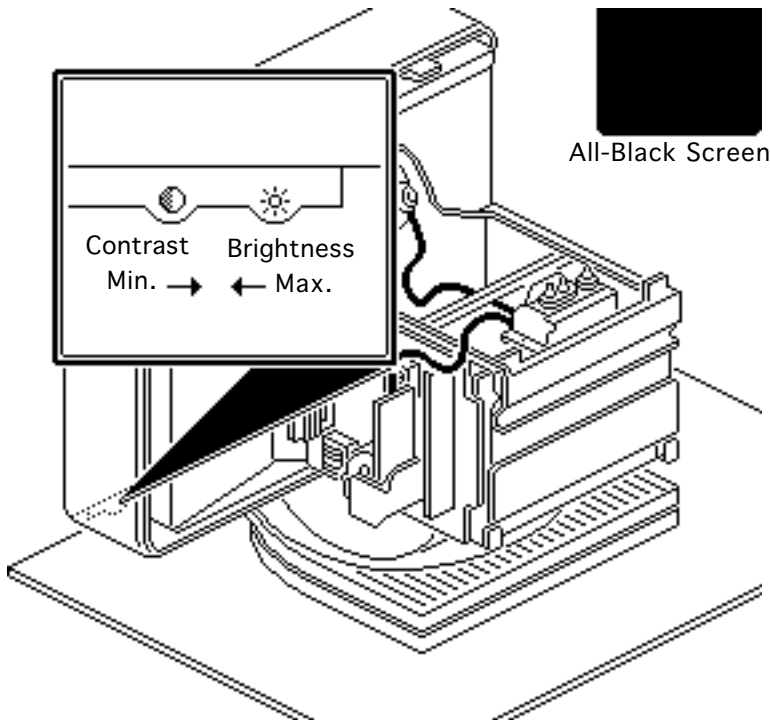

Note: To perform the video adjustments you will need a compass, light meter, and voltmeter.

- 1 Using Display Service Utility, display All-Black Screen.
- 2 Set the external brightness control to maximum brightness (turn fully clockwise).
- 3 Set the external contrast control to minimum contrast (turn fully counterclockwise).



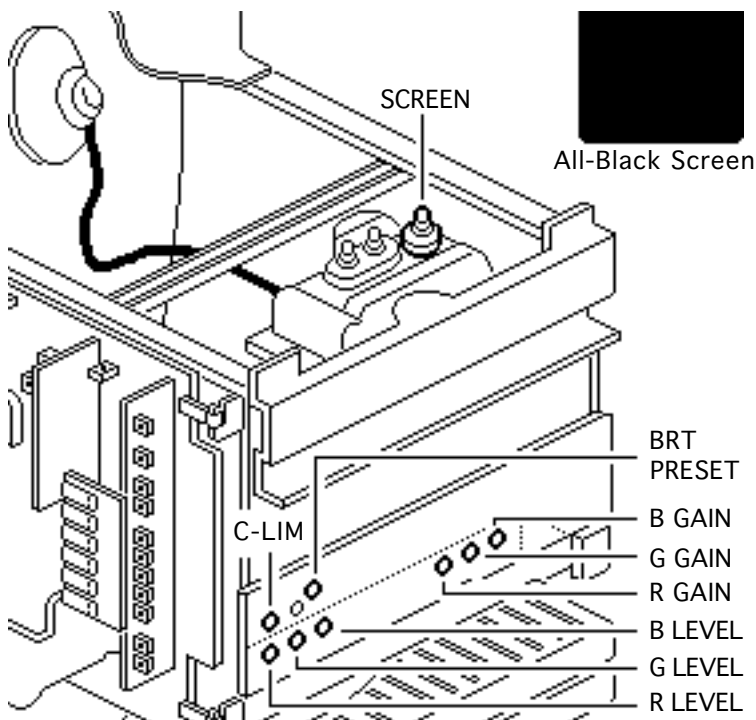

4 Using the insulated screwdriver, preset these controls to minimum (turn fully counterclockwise):

- SCREEN (high-voltage block)
- C-LIM (video assembly)
- BRT PRESET (video assembly)
- B, G, and R GAIN (video assembly)
- B, G, and R LEVEL (video assembly)

Note: For the next step, make sure the voltmeter is



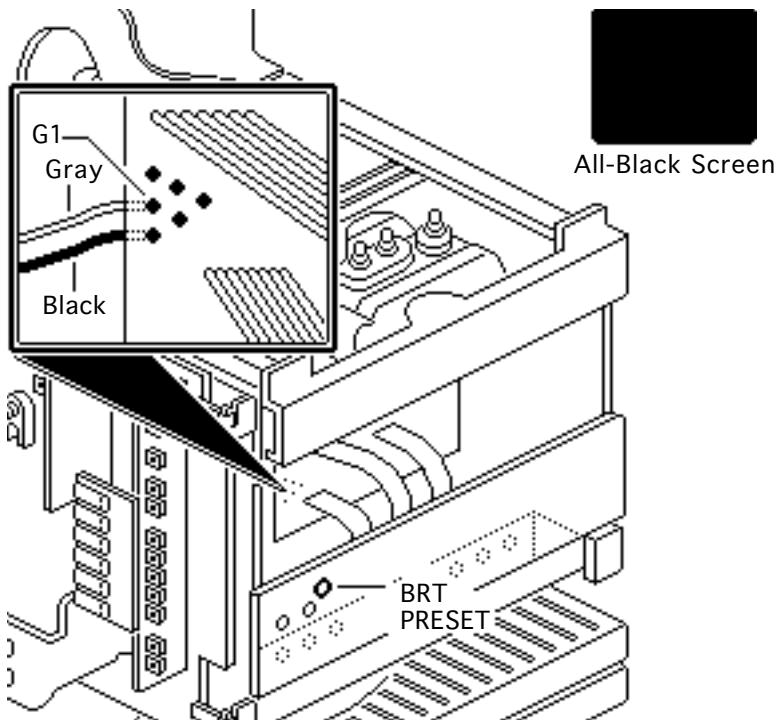

grounded to the monitor chassis and set to the 200 VDC setting.

Note: Because the voltage at G1 is a negative number, increasing the voltage can be confusing. If the initial voltage was -61 V, increasing the voltage by 4 volts would read -57 V.

- 5 Using the insulated screwdriver and a voltmeter, adjust the BRT PRESET control until the voltage at G1 increases by 4 volts (± 0.2 V).



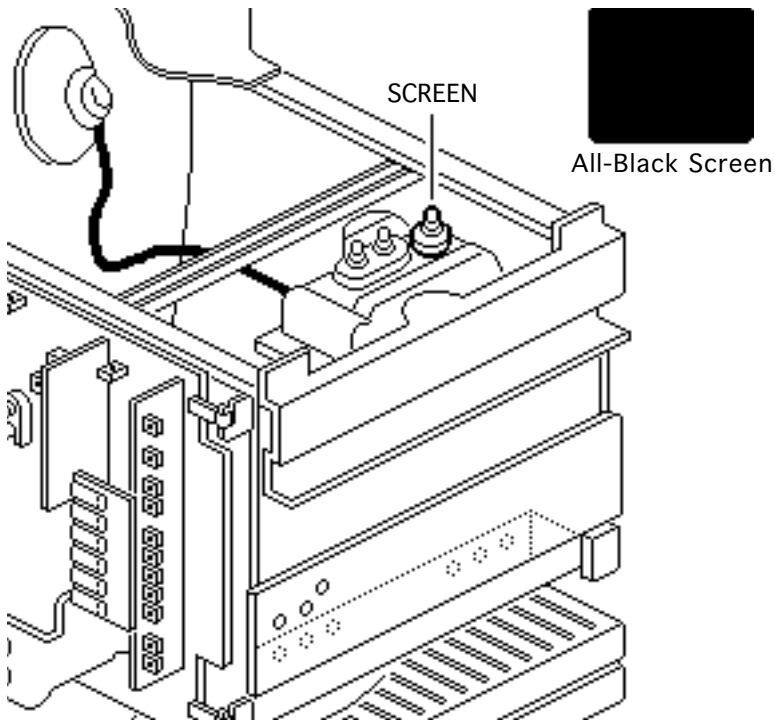

- 6 Adjust the SCREEN control until the raster just appears. (The entire screen should be obviously tinted, but dark.)



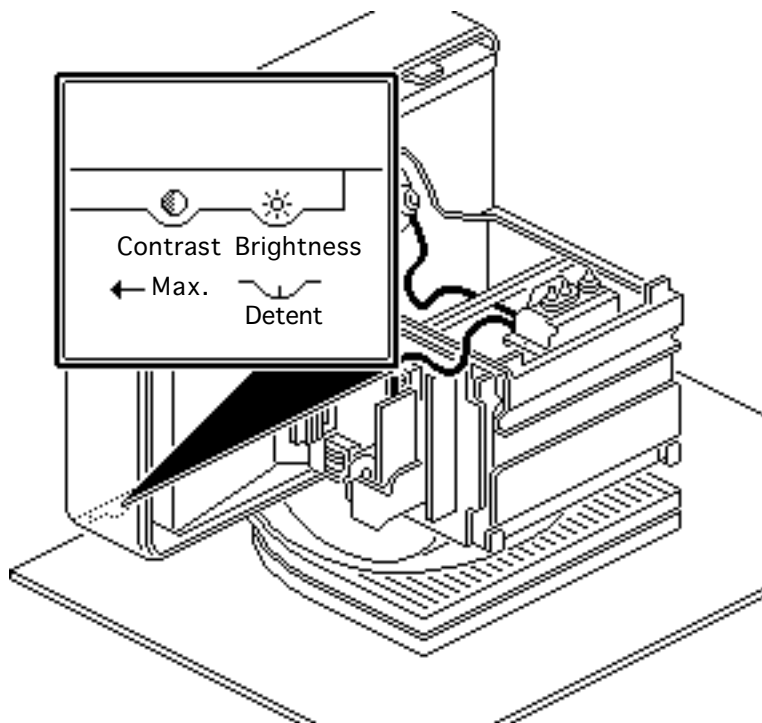

- 7 Set the external brightness control to its center detent position.
- 8 Set the external contrast control to maximum contrast (turn fully clockwise).



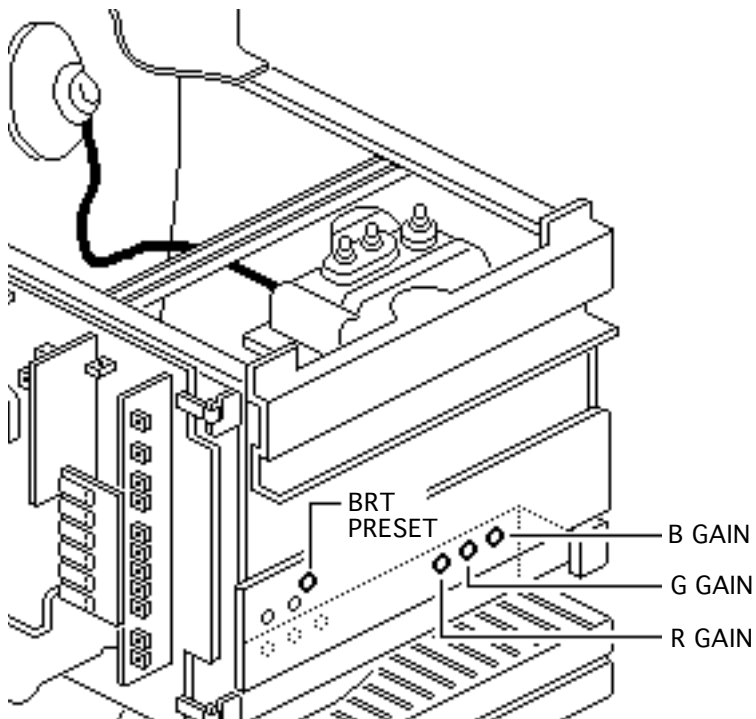

- 9 Using the insulated screwdriver, turn the red, green, and blue GAIN controls to midrange.
- 10 Using the insulated screwdriver, adjust the BRT PRESET control to minimum (turn fully counterclockwise).



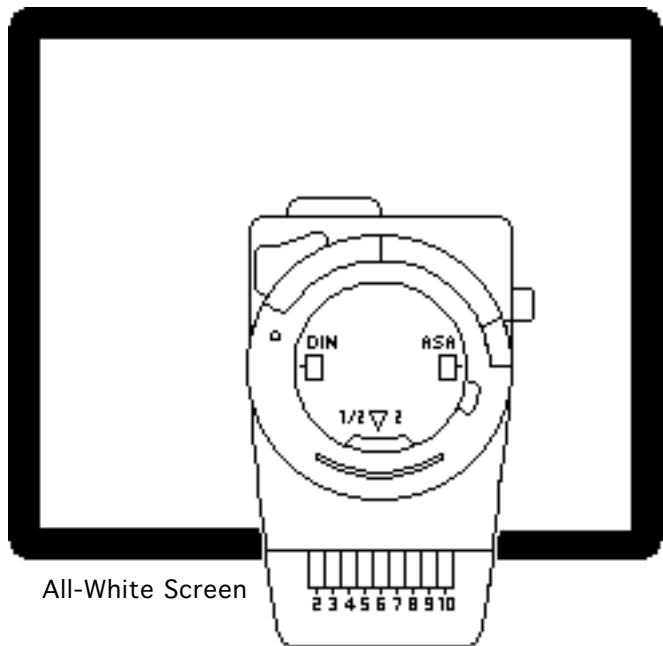

Important: Readings from light meter models R77, L-248, and 246 differ. Please note which meter you are using before making adjustments. (See “Light Meter Setup.”)

- 11 Using Display Service Utility, display All-White Screen.



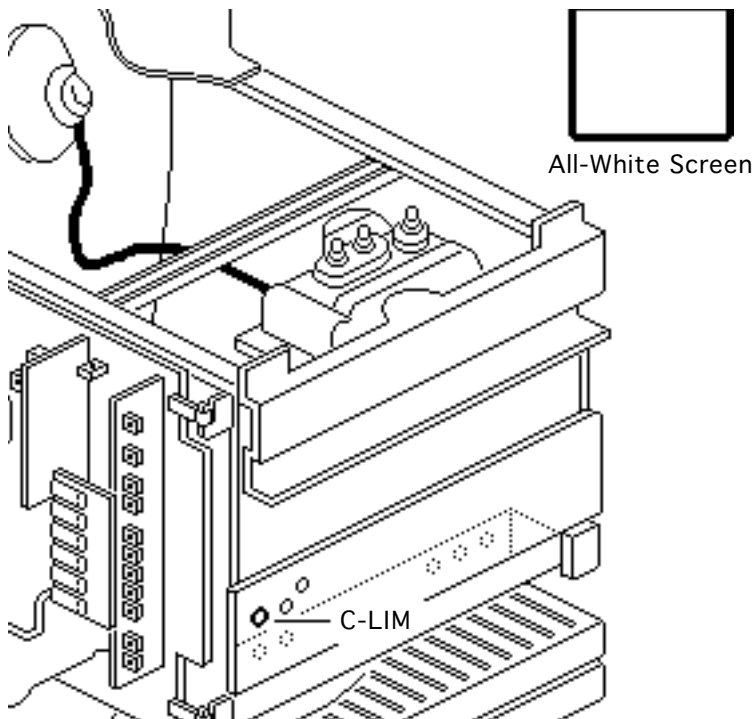

12 Using the light meter and an insulated screwdriver, adjust the C-LIM control until the center of the all-white screen measures 27 foot lamberts (± 3 foot lamberts), which on the light meter is

- Model R77: between 21 and 22 on the bottom scale
- Model L-248: low end of the 10 scale
- Model 246: 21.5 on the red scale





Important: If you cannot attain the correct reading, turn up (clockwise) 1/4 turn the three GAIN controls and repeat the C-LIM adjustment. If you doubt your meter's accuracy, verify the readings with a known-good light meter or photometer.



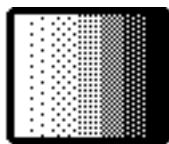
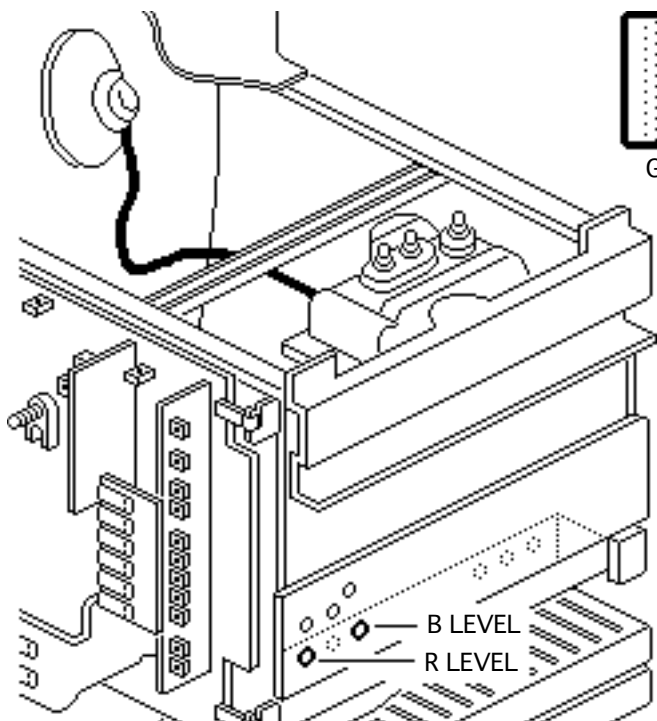

Gray Bars

- 13 Using Display Service Utility, display Gray Bars.
- 14 Using the insulated screwdriver, alternately adjust the red and blue LEVEL controls until there is no colored tint in the right (darkest) five bars.

Note: Use the green LEVEL control only if you cannot adjust the dark bars with the red and blue LEVEL controls.



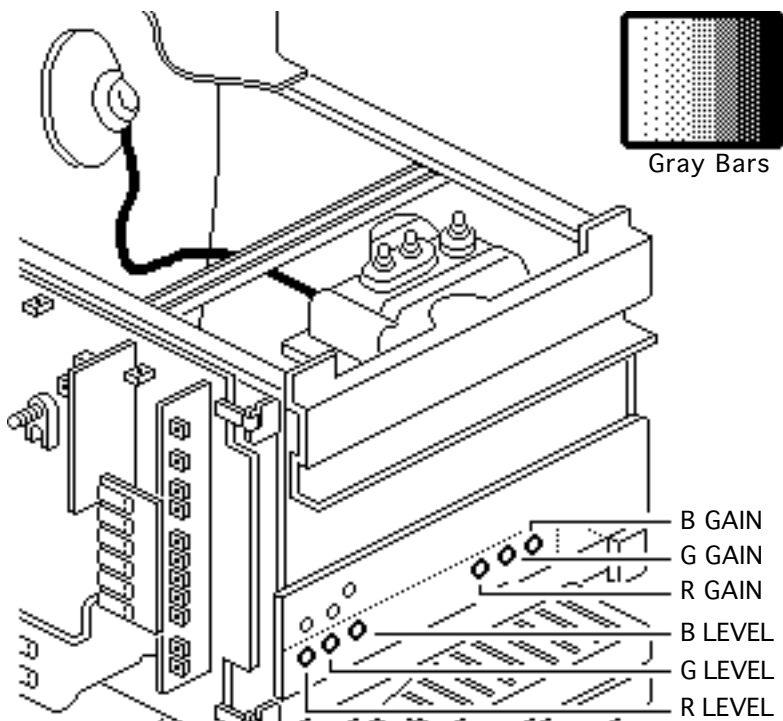

15 Using the insulated screwdriver, alternately adjust the three GAIN controls until there is no colored tint in the left (brightest) five bars.

16 Recheck the right (darkest) bars for a colored tint. If necessary, repeat the LEVEL and GAIN adjustments until there is no colored tint.



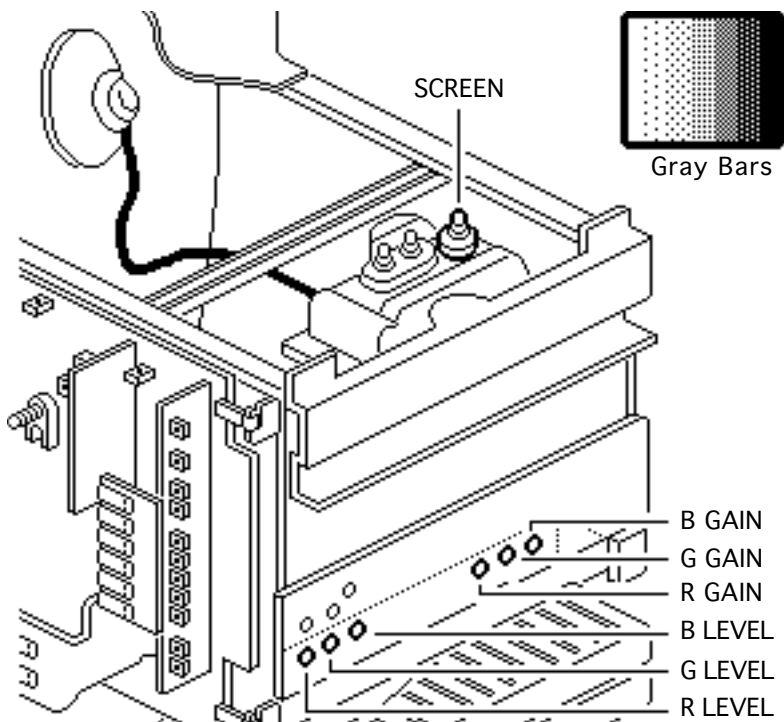

17 Adjust the SCREEN control until the rightmost bar is as black as the border and the second bar is barely distinguishable from the black bar.

18 Recheck the gray bars for a colored tint. If necessary, repeat the LEVEL, GAIN, and SCREEN adjustments.



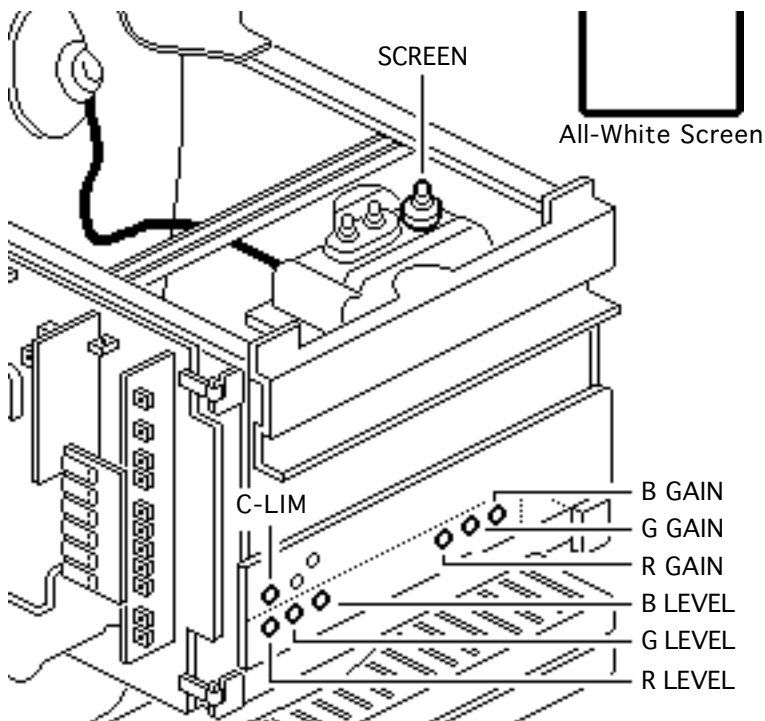

19 Using Display Service Utility, display All-White Screen.

20 Recheck screen luminance. If necessary, adjust the C-LIM control until the center of the all-white screen measures 27 foot lamberts (± 3 foot lamberts), which on the light meter is

- Model R77: 21.5 on the bottom scale
- Model L-248: low end of the 10 scale
- Model 246: 21.5 on



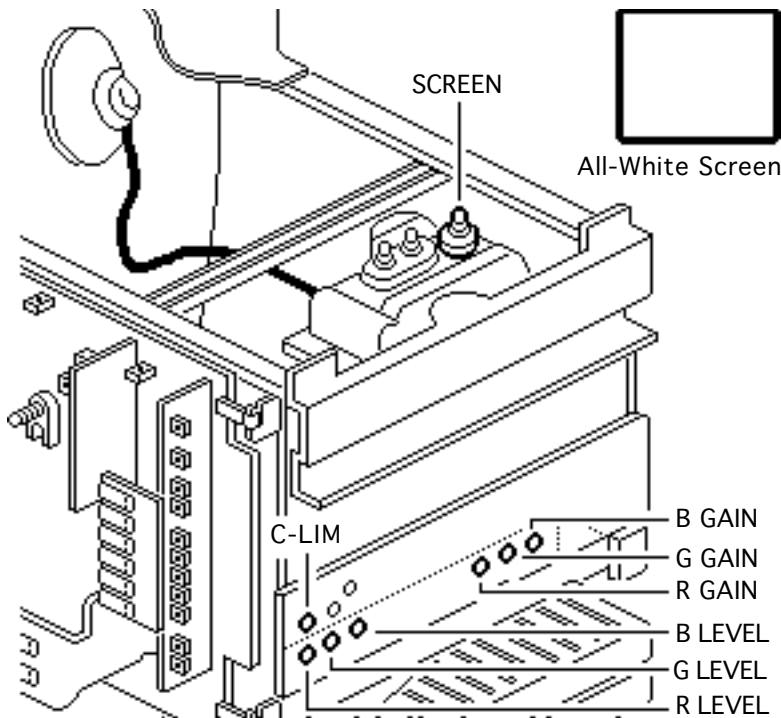

the red scale

Important: If you cannot attain the correct reading, turn up (clockwise) 1/4 turn the three GAIN controls and repeat the C-LIM adjustment. If you doubt your meter's accuracy, verify the readings with a known-good light meter or photometer.

- 21 Recheck the gray bars for a colored tint. If necessary, repeat the LEVEL, GAIN, SCREEN, and C-LIM adjustments.





Light Meter Setup

This topic covers setup for three light meter models: R77, L-248, and 246. Model R77 (Apple part number 076-0310) is the newest model available.

Model R77

The R77 light meter is capable of reading luminance from 10 to 1,000 footcandles (fc).

Before you begin, remove the 10X multiplier plate



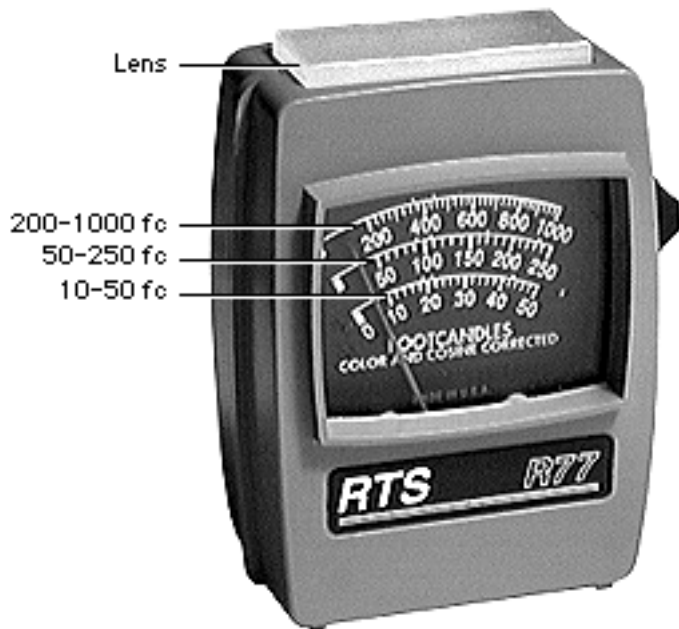

from the lens.

Three scales are shown on the light meter:

- 200-1000 fc
- 50-250 fc
- 10-50 fc

Because display screen luminance typically ranges from 10 to 50 fc, take readings from the bottom scale only.



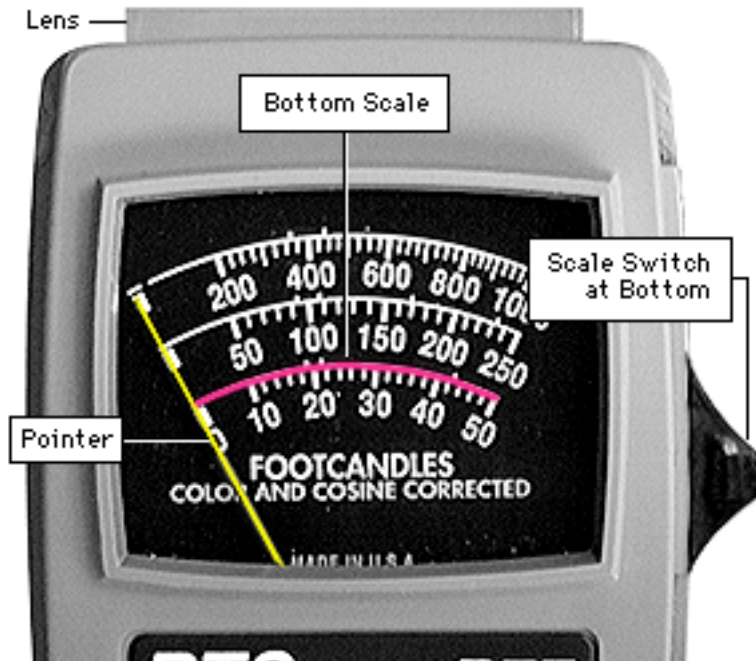

To measure a display screen's luminance,

- 1 Set the scale switch to the bottom position (to set up the 10-50 fc scale).
- 2 Place the lens against the middle of the screen and read the bottom scale.

Note: When the light meter is not in use, slide the scale switch to its top position, and store the meter in its protective case.

Important: If you suspect the light meter is giving false



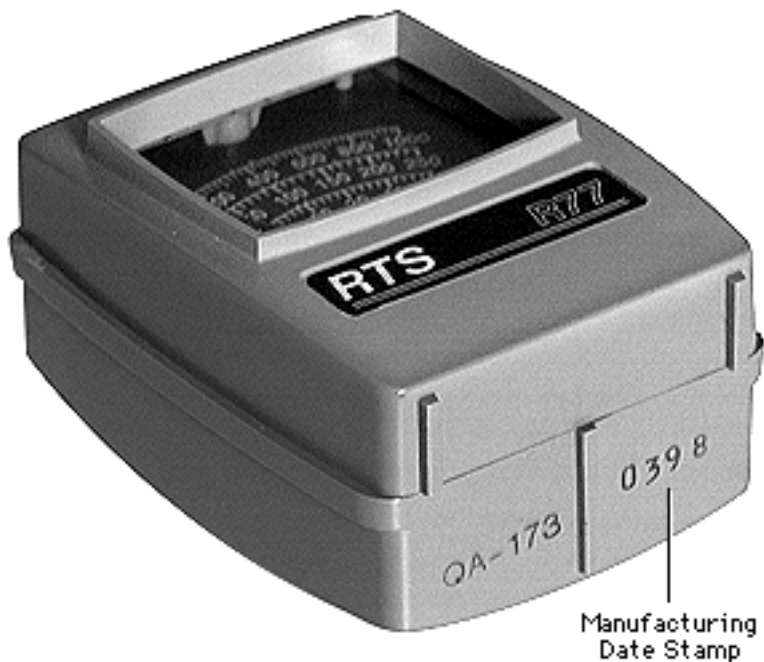

readings, verify the readings with a known-good light meter or photometer. Also check the age of the R77 light meter by its four-digit manufacturing date stamp (such as 0398 for March 1998).

Caution: Dropping the meter can permanently damage its accuracy. A shock-damaged meter might read incorrectly or its pointer may not drop to zero.



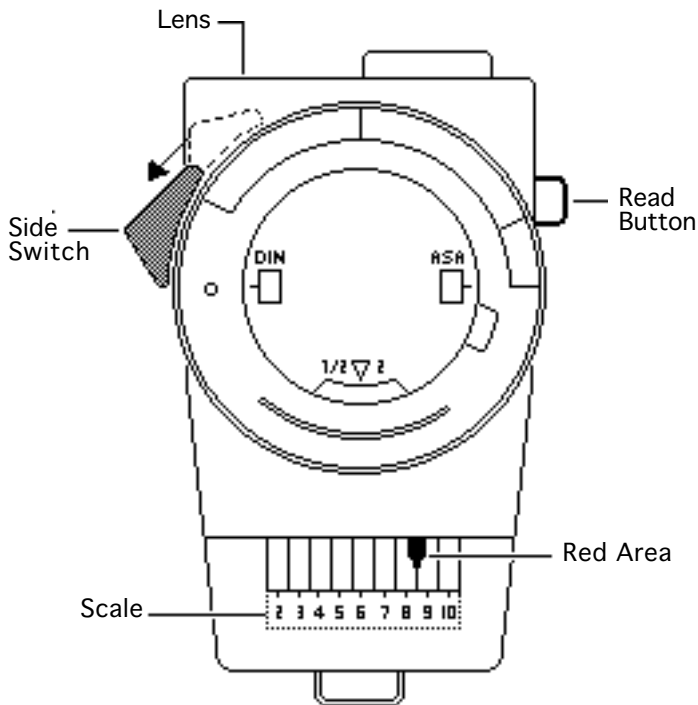

Model L-248

- 1 Press the red button on the back of the light meter. If the reading is out of the red area, replace the battery.
- 2 Move the side switch to its lower position so that the scale reads 2 through 10.
- 3 Uncover the lens of the meter.
- 4 Place the lens against the middle of the screen and press the read button to read the scale.



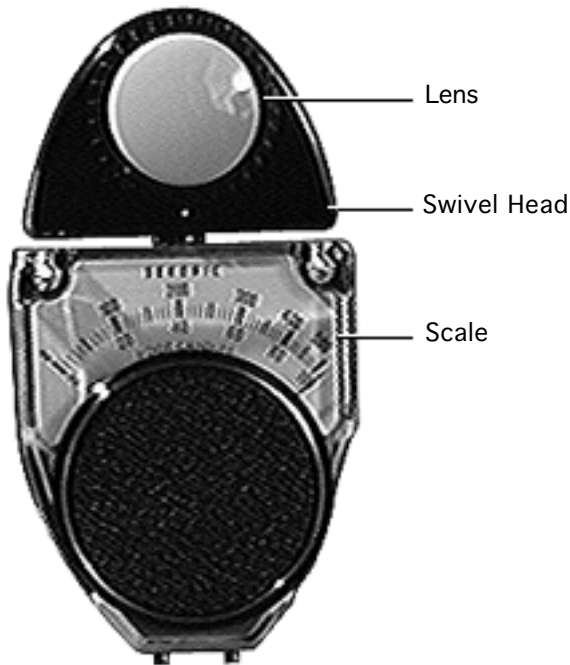

Model 246

- 1 Remove the metal slide, if installed, from the top of the light meter.
- 2 Install the white lens with the red dot.
- 3 Rotate the swivel head so the lens of the meter faces the monitor.

Place the lens against the middle of the screen and read the scale.





Exploded View

Macintosh 21 Color Display



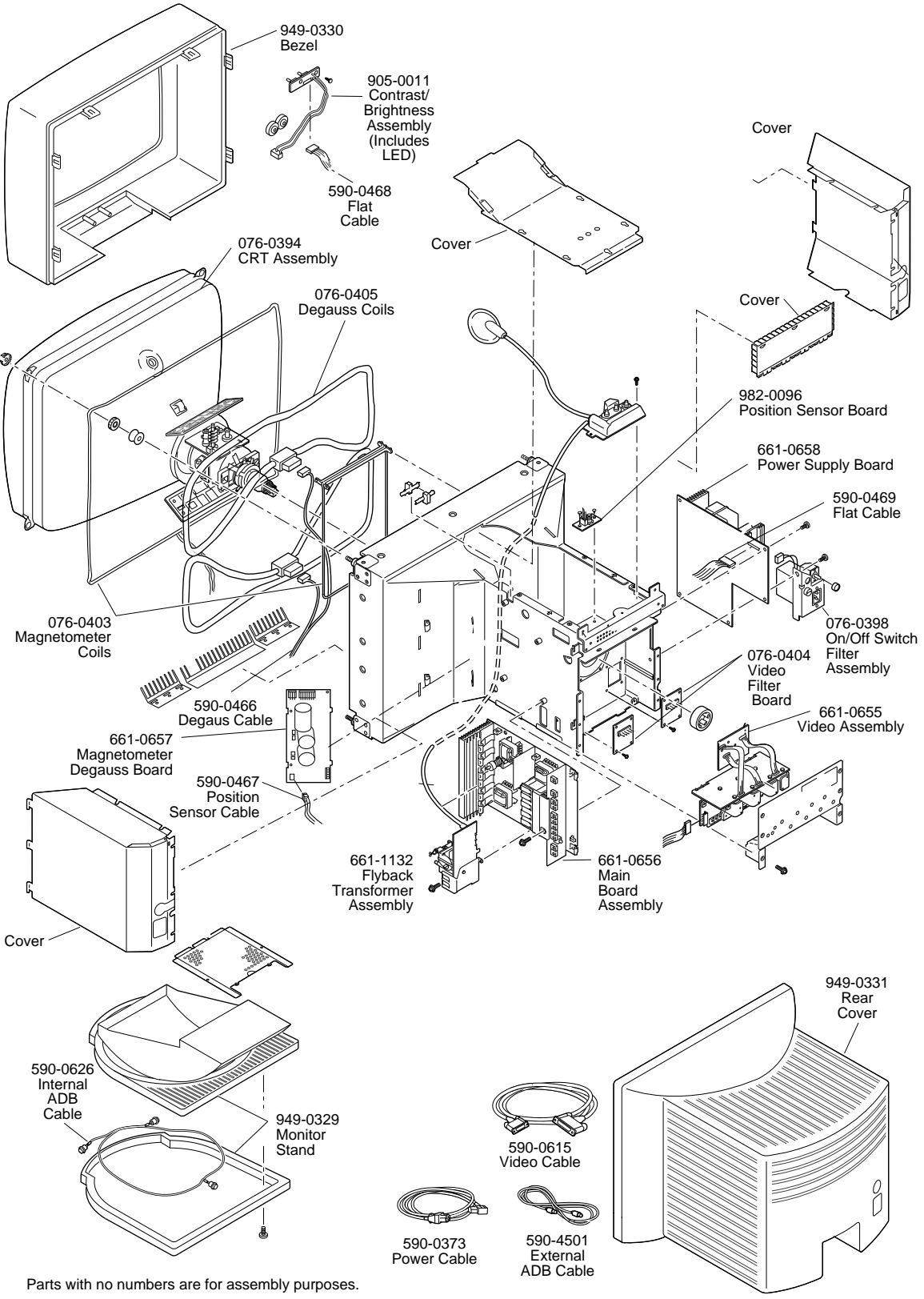

Parts with no numbers are for assembly purposes.

