



Apple AudioVision 14 Display





Basics

Apple AudioVision 14 Display





Self-Threading Screws

Caution: Improperly installed self-threading screws could damage the AudioVision 14 Display. Thread the screws properly and do not overtighten them.

The AudioVision 14 Display uses both machine screws and self-threading screws. Be aware of the following guidelines when you are replacing a self-threading screw:

- Never overtighten self-threading screws.
- Before tightening a self-threading screw, back the screw off slightly to be sure it is threaded properly.





Machine Screw

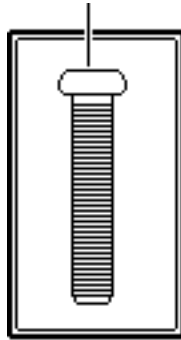

Self-Threading Screw

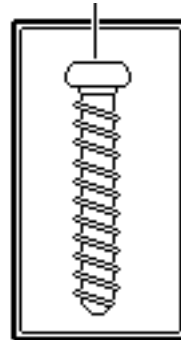



Specifications

Apple AudioVision 14 Display





Characteristics

Picture Tube	14-inch diagonal, 13-inch viewable screen Trinitron CRT .26-mm pitch aperture grille
Screen Resolution	640x480
Scan Rates	Horizontal scan rate: 35.0 kHz Vertical refresh rate: 66.7 Hz
Active Video Display Area	9.3 in. by 6.9 in. (235 mm by 176 mm)



**Video Input Signals**

Red, green, and blue video signals;.714 V peak to peak; white positive

Composite synchronization, negative-going TTL

Audio Input Signals

Accepts audio signal of up to 6 Vpp (line level—low sensitivity) or as low as 20 mVpp (microphone level—high sensitivity) without clipping the signal, depending upon the level and sensitivity setting

Microphone

Directional, optimized for use in speech recognition and other voice-related applications

Speakers

Stereo, with ported (base reflex) chamber design

Minimum loudness: 90 dB SPL at 1 kHz at 0.5 m

Frequency response: 100 Hz–15 kHz \pm 3dB





Headphone Jack

Output level: 1.75 Vpp into 4 ohm load and 2 Vpp into 10 k ohm load





Controls

User Controls

Front Keypad: Contrast, brightness, and volume keys; mute button; microphone button

Back panel: On/off switch





Electrical

Voltage

100-240 VAC \pm 10%

Frequency

50-60 Hz \pm 3%

55 W maximum, all line conditions

Power

The monitor contains internal power-line fuse protection.

This fuse should be replaced with the same type by a qualified service technician.





Physical

Size

Height: 13 in. (330 mm)

Width: 13.5 in. (344 mm)

Depth: 15.5 in. (394 mm)

Weight

33 lb. (15 kg)

Warm-Up Time

20 minutes required to meet all specifications





Environmental

**Operating
Temperature**

50-104°F (10-40°C)

Relative Humidity

90% maximum, noncondensing





Troubleshooting

Apple AudioVision 14 Display





General

The Symptom Charts included in this chapter will help you diagnose specific symptoms related to your product. Because cures are listed on the charts in the order of most likely solution, try the first cure first. Verify whether or not the product continues to exhibit the symptom. If the symptom persists, try the next cure. (Note: If you have replaced a module, reinstall the original module before you proceed to the next cure.)

If you are not sure what the problem is, or if the Symptom Charts do not resolve the problem, refer to the Flowchart for the product family.

For additional assistance, contact Apple Technical Support.





Symptom Charts

No Raster

No raster, LED off

- 1 Ensure monitor's video cable is connected to the computer or the video card in the computer.
- 2 Check power cable connections and power switch.
- 3 Check all connections on main board.
- 4 Replace blown fuse.
- 5 Replace main board.

No raster, LED on,
CRT filament on

- 1 Ensure monitor's video cable is connected to the computer or the video card in the computer.
- 2 Adjust contrast and brightness knobs.
- 3 Connect known-good monitor and verify that built-in video signal or video card is working properly.
- 4 Check all connections on main board. Make sure video connector is secure and wires are inside plastic connector.
- 5 Perform video adjustments. Refer to "Video" in Adjustments chapter.
- 6 Replace main board.
- 7 Replace CRT.





Geometry

Raster too short, tall,
narrow, or wide

- 1 Adjust vertical or horizontal size controls. Refer to “Geometry” in Adjustments chapter.
- 2 Replace main board.

Raster not centered

- 1 Move unit away from monitors, fluorescent lights, or other electrical equipment.
- 2 Adjust vertical or horizontal center controls. Refer to “Geometry” in Adjustments chapter.
- 3 Replace main board.

Horizontal linearity
bad (size of text
differs at sides of
screen)

Replace main board.





Geometry (Continued)

Vertical linearity bad
(size of text differs at
top vs. bottom of
screen)

Replace main board.

Abnormal or
distorted raster

- 1 Move unit away from monitors, fluorescent lights, or other electrical equipment.
- 2 Perform geometry adjustments. Refer to “Geometry” in Adjustments chapter.
- 3 Replace main board.
- 4 Replace CRT (rarely required).





Geometry (Continued)

Entire raster is tilted

- 1 Move unit away from monitors, fluorescent lights, or other electrical equipment.
- 2 Perform geometry adjustments. Refer to “Geometry” in Adjustments chapter.
- 3 Perform geometric distortion adjustments. Refer to “Geometric Distortion” in Adjustments chapter.
- 4 Replace main board.





Synchronization

Picture breaks into diagonal lines

- 1 Connect known-good monitor and verify that built-in video signal or video card is working properly.
- 2 Replace main board.

Picture rolls vertically

- 1 Connect known-good monitor and verify that built-in video signal or video card is working properly.
- 2 Replace main board.

Picture breaks and rolls horizontally

- 1 Connect known-good monitor and verify that built-in video signal or video card is working properly.
- 2 Replace main board.





Synchronization (Continued)

Black raster with
single vertical or
horizontal line

- 1 Replace main board.
- 2 Replace CRT.





Video

Raster too dark, too bright, or washed out

- 1 Adjust external contrast and brightness controls.
- 2 Connect known-good monitor and verify that built-in video signal or video card is working properly.
- 3 Perform video adjustments. Refer to “Video” in Adjustments chapter.
- 4 Replace main board.
- 5 Replace CRT (rarely required).

Out of focus

- 1 Perform focus adjustment. Refer to “Video” in Adjustments chapter.
- 2 Replace main board.
- 3 Adjust focus controls to their limits. If bad focus remains on one part of display, replace CRT.





Video (Continued)

Predominant color tint

- 1 Check video card in computer.
- 2 Perform video adjustments. Refer to “Video” in Adjustments chapter.
- 3 Replace main board.
- 4 Replace CRT (if you cannot eliminate red, green, or blue tint).

Out of convergence (color bleeding out from text or lines)

- 1 Connect known-good monitor and verify that built-in video signal or video card is working properly.
- 2 Perform convergence adjustments. Refer to “Video” in Adjustments chapter.
- 3 Replace main board.
- 4 Replace CRT.





Audio

Sound comes out of only one speaker

One of sound output options may be set to Stereo when your computer is only capable of Mono sound output.

Internal microphone doesn't record

- 1 To turn on microphone, press microphone button on keypad. Microphone-on LED lights up when microphone is on.
- 2 Make sure that monitor is selected as sound input and playback source.

No sound or volume is too low

- 1 Verify that external sound sources are securely connected to monitor's sound-out port.
- 2 Press volume key on keypad.
- 3 Press mute button to turn mute off.
- 4 Press microphone button to turn microphone off.





Miscellaneous

Picture jitters or
flashes

- 1 Move unit away from monitors, fluorescent lights, or other electrical equipment.
- 2 Check that all ground cables are secure.
- 3 Replace main board.

Intermittently shuts
down

Replace main board.

Flashing or wavy
screen

Replace main board.

Black screen spots
(burnt phosphor)

Replace CRT.



**Miscellaneous (Continued)**

Monitor emits high-pitched noise

Replace main board.

Does not degauss

Replace main board.

Erratic or no communication with ADB device

Replace keyboard cable, keyboard, mouse, or other ADB device.

Moving and clicking a Logitech mouse has no effect on screen, but keyboard input is accepted

Some models of Logitech mice are incompatible with this display. Refer customers to Logitech for information on mouse compatibility and upgrades. The display is not at fault; do not replace it.





Miscellaneous (Continued)

Thin horizontal line
on screen

Displays smaller than 15 inches with tron-style CRTs typically have a single horizontal grid wire about one-third of the way from the bottom of the display image. This supporting wire, which is thinner than a human hair, stabilizes the aperture grill against shocks. The line is common to all tron-style displays and is not a screen defect. It cannot be adjusted out or eliminated by repairing or replacing display modules.





Take Apart

Apple AudioVision 14 Display



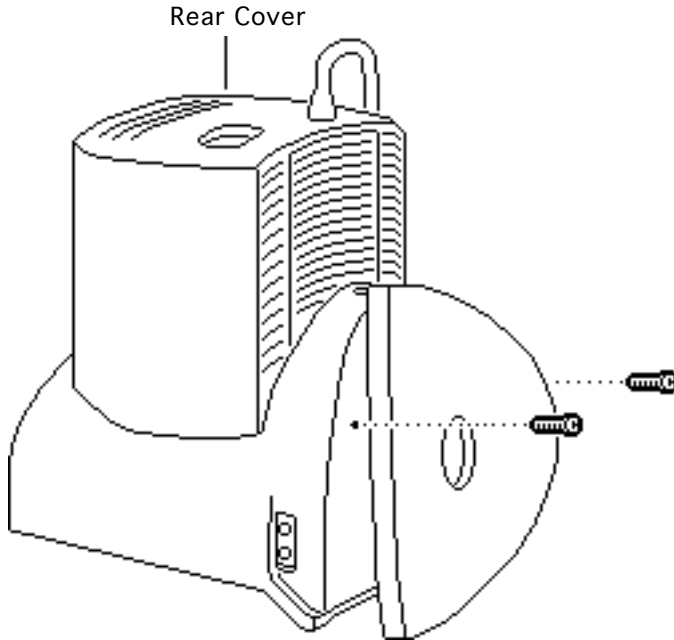

Rear Cover

No preliminary steps are required before you begin this procedure.

- 1 With the monitor face-down on a protective pad, swivel the monitor stand to access the two rear cover screws.
- 2 Using a T-15 torx driver, remove the screws.



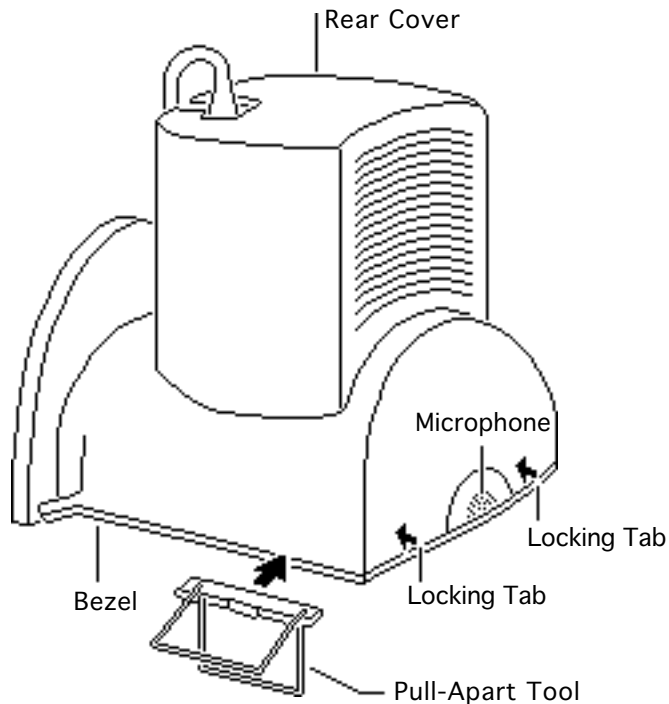

- 3 Move the monitor so that the microphone is toward you.
- 4 **Note:** The locking tabs are located 1.5 inches in from the sides of the rear cover.

Press down on the locking tabs. Using the pull-apart tool, pry apart the sides of the rear cover.



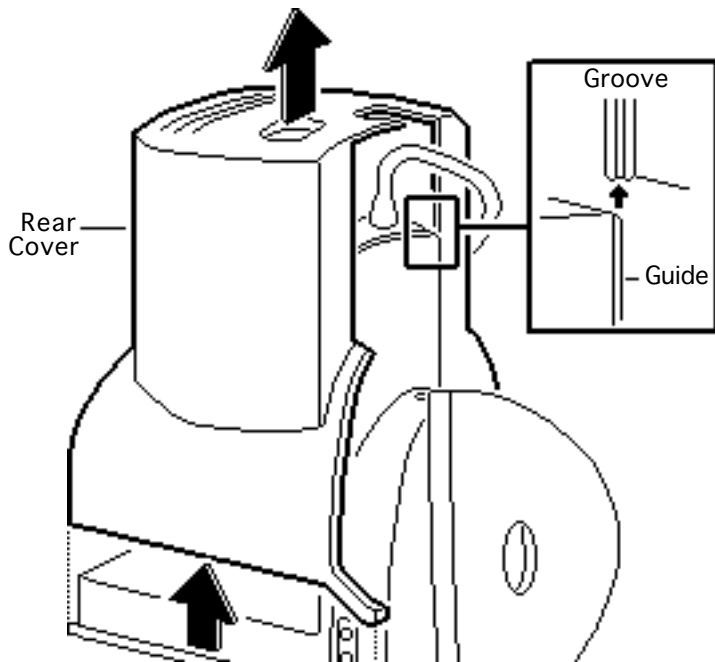

- 5 Lift off the rear cover.

Replacement Note: Line up the rear cover grooves with the base assembly guides and slide on the rear cover.





Audio Enclosure & Speakers

Before you begin,

- Remove the rear cover
- Discharge the CRT
- Remove the anode cap

⚠ Warning: This product contains high voltage and a high-vacuum picture tube. To prevent serious injury, review CRT safety in Bulletins/Safety.

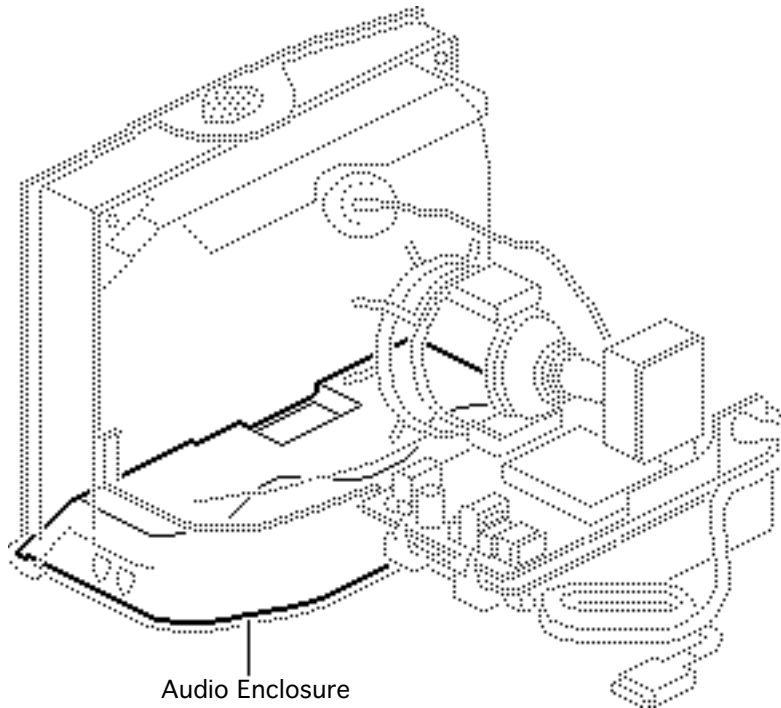

Audio Enclosure



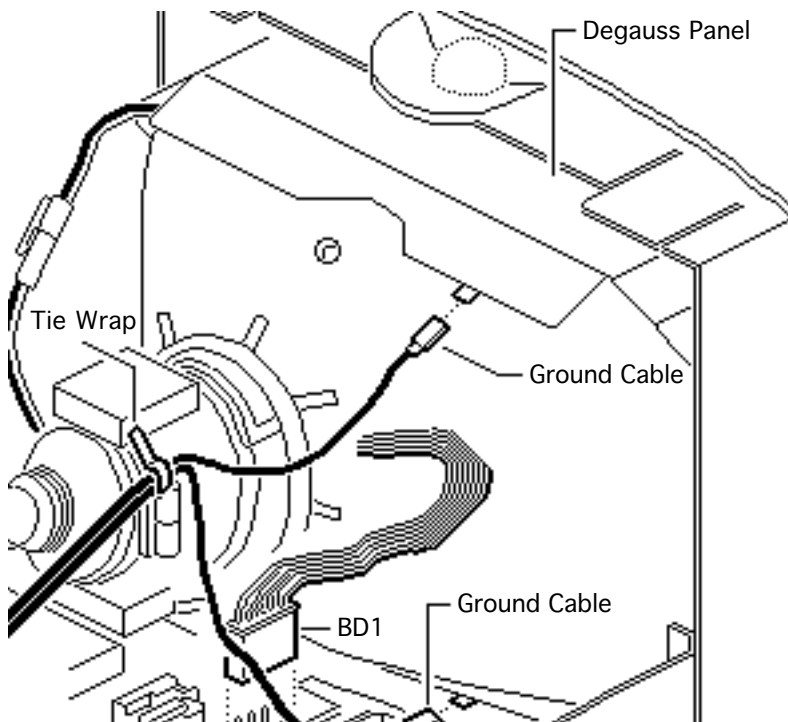

⚠ Warning: Never use a grounding wriststrap until after discharging the CRT.

- 1 Cut the tie wrap from the yoke and two ground cables.
- 2 Disconnect the two ground cables from the degauss panels.
- 3 Disconnect the 4-pin, 4-wire CRT cable from connector BD1.



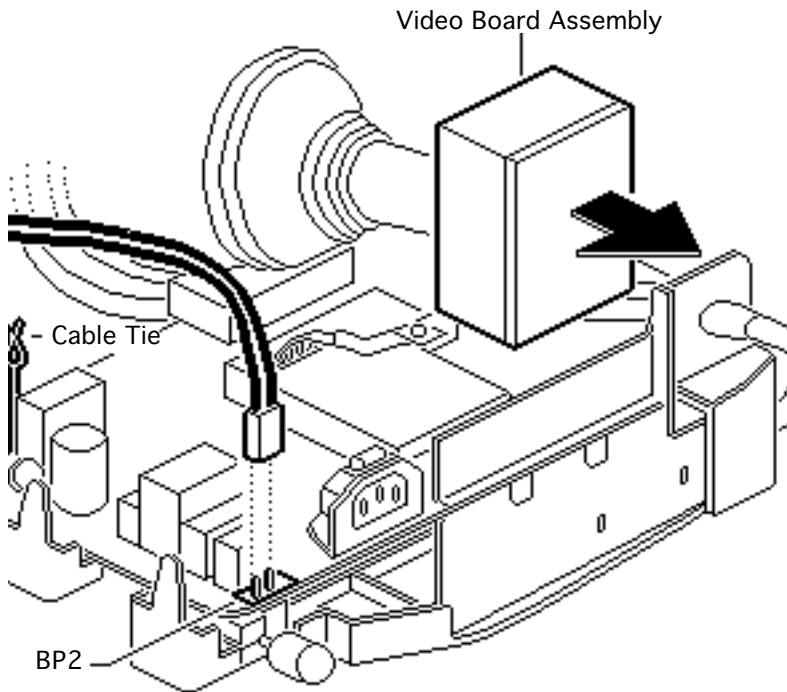

- 4 **Caution:** Twisting, bending, or applying force to the video board assembly could damage the neck of the CRT. Be sure to pull the video board assembly straight off the CRT.

Pull the video board assembly straight off the neck of the CRT.

- 5 Cut the tie wrap that connects cables BP2 and BP3.
- 6 Undo the cable tie that connects cables BP2 and BP4.



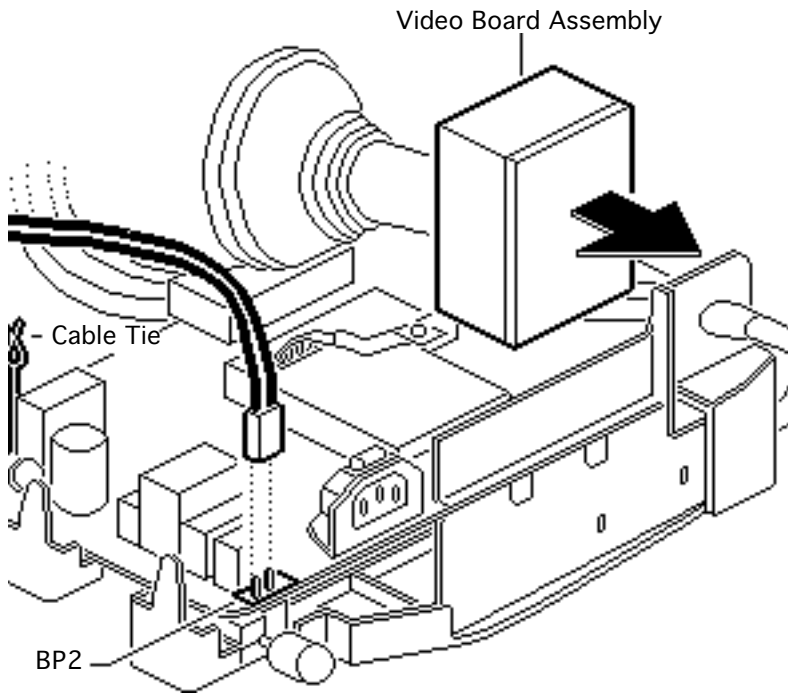

- 7 Disconnect the degauss cable from connector BP2.



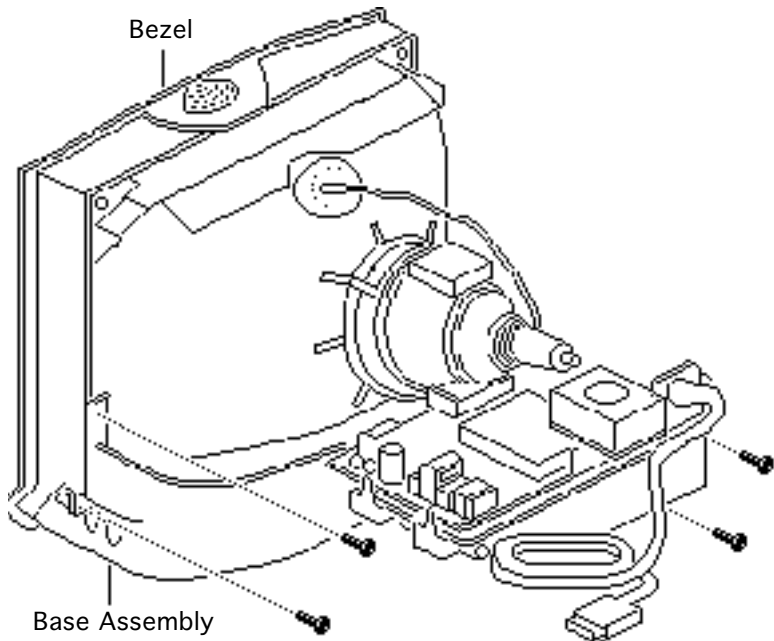

- 8 Using a T-15 torx driver, remove the four self-threading screws that secure the base assembly to the bezel.

Replacement Caution:
Do not overtighten the four self-threading screws. See Basics section for more information regarding self-threading screws.



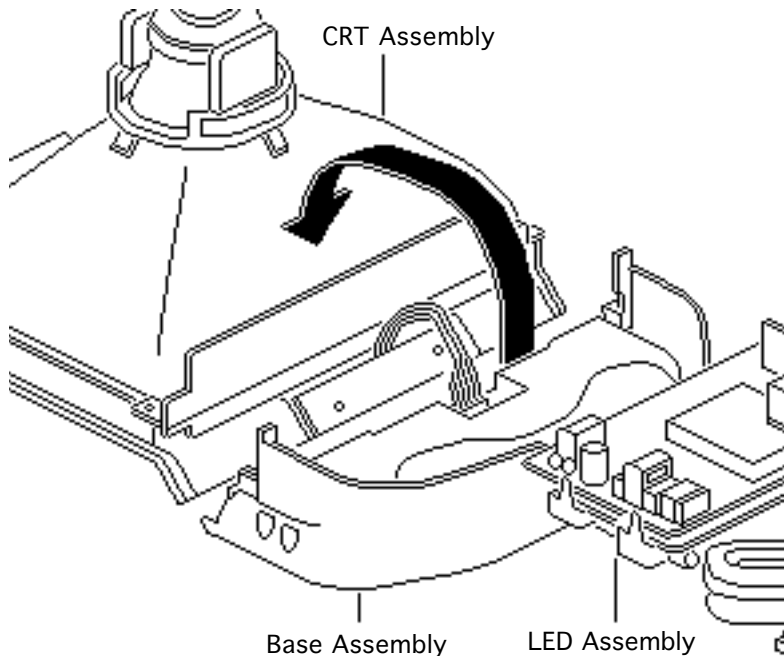

- 9 **Caution:** The CRT assembly is connected to the base by LED and microphone cables. Be careful not to tear these cables when separating the CRT from the base assembly.

Lift the CRT assembly off the base and place it face-down on a protective workbench pad.



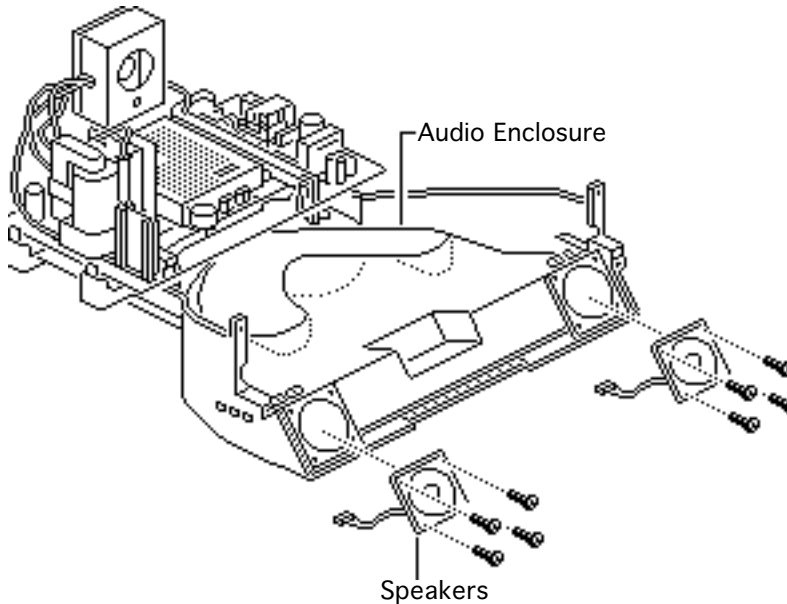

10 **Note:** Perform this step if you are replacing the speakers only.

Using a T-15 torx driver, remove the eight self-threading screws that secure the speakers to the audio enclosure.

11 Disconnect both speaker cables.

12 Remove the speakers.





Replacement Caution:

Do not overtighten the self-threading screws. See Basics section for more information regarding self-threading screws.



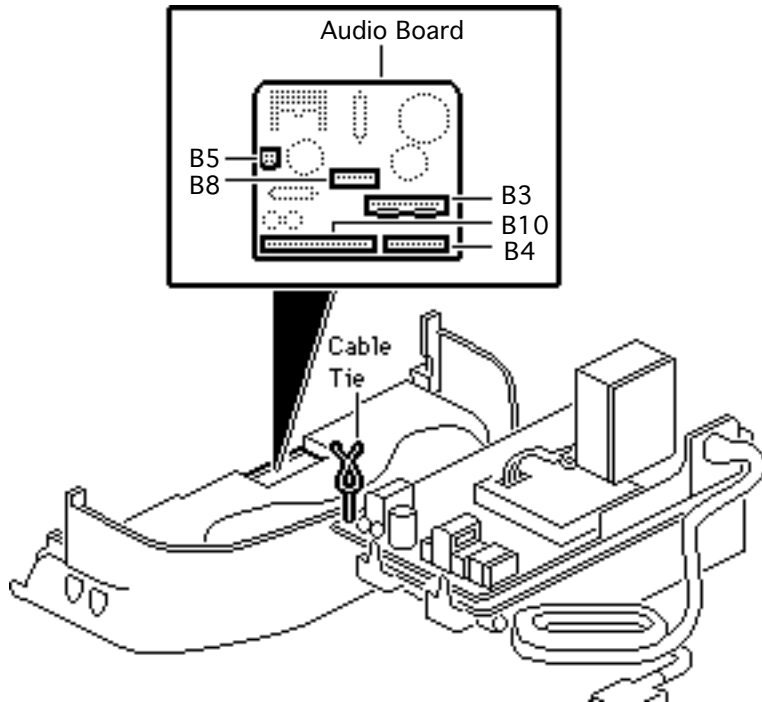

13 Using a jeweler's screwdriver, release the latches and disconnect these cables from the audio board:

- Microphone cable from B5
- Front panel controls and LEDs cable from B3
- Video cable from B4
- Video cable from B10
- Four-wire cable from B8

14 Undo the cable tie that connects the video cable to the audio enclosure.



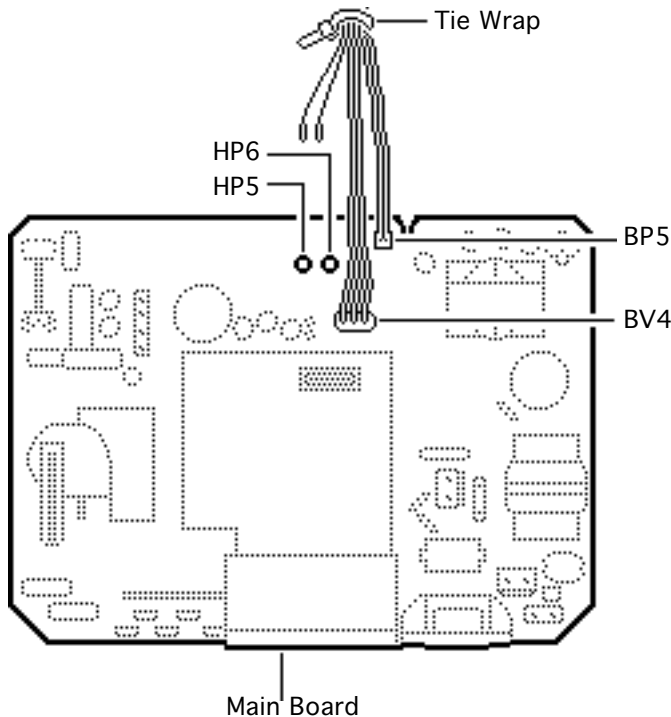

- 15 Cut the tie wrap that secures the cables to connectors BP5, BV4, HP5, and HP6.
- 16 Disconnect the audio ground cables from connectors HP5 and HP6 on the main board.



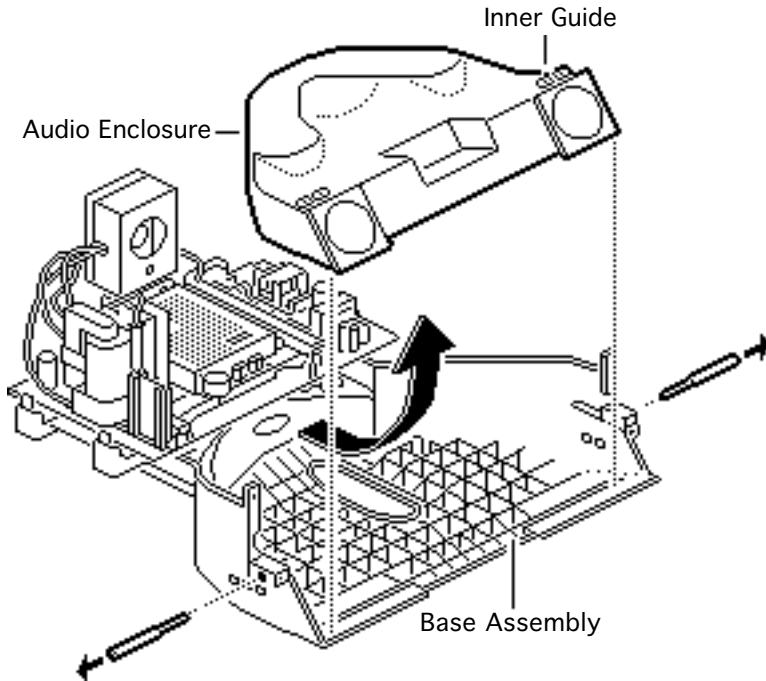

17 Using a flat-blade screwdriver, loosen the two screws that secure the base assembly to the audio enclosure.

18 Using pliers, pull out the two screws.

19 Slide out and remove the audio enclosure assembly.





Video Cable & Strain Relief

Before you begin,

- Remove the rear cover
- Discharge CRT
- Remove the anode cap
- Remove the audio enclosure & speakers

⚠ Warning: This product contains high voltage and a high-vacuum picture tube. To prevent serious injury, review CRT safety in Bulletins/Safety.

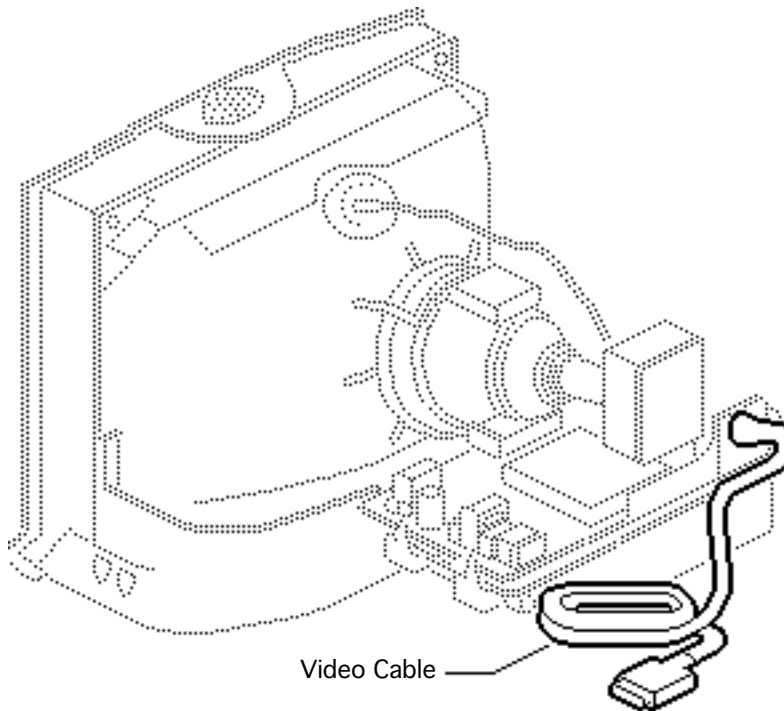

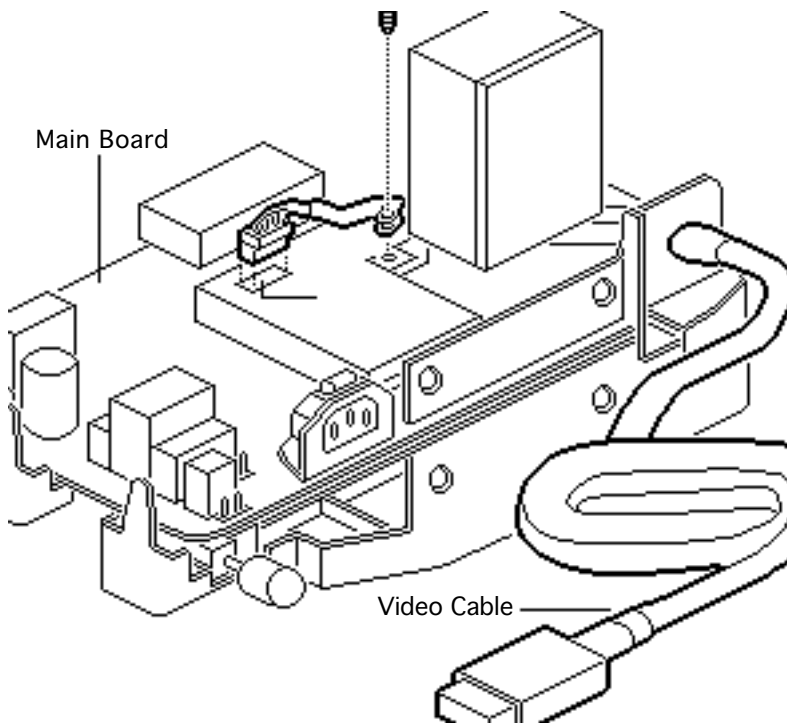

⚠ Warning: Never use a grounding wriststrap until after discharging the CRT.

- 1 Remove the screw that secures the video cable to the EMI shield on the main board.
- 2 Remove the video cable from connector BV1.



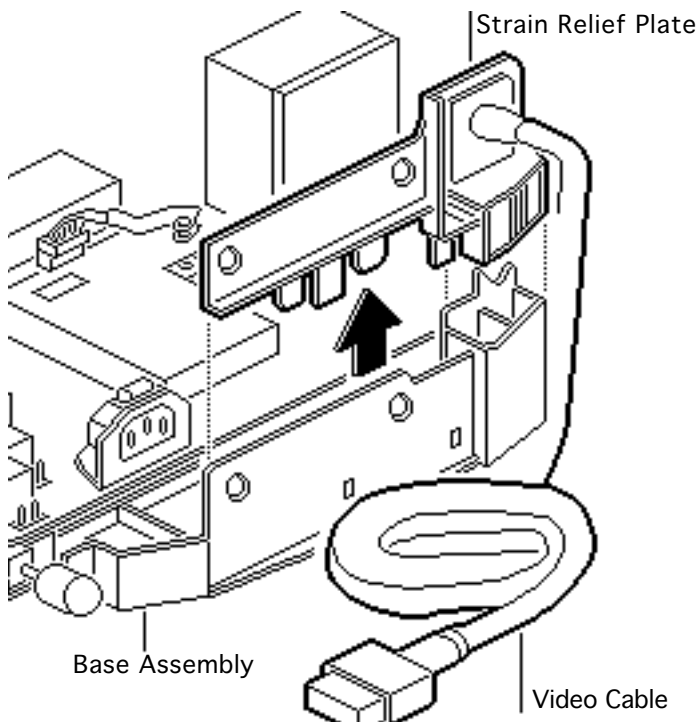

- 3 Press in the two tabs to release the strain relief plate from the base assembly.
- 4 Lift and remove the strain relief plate with the attached video cables off the base assembly.
- 5 Remove the video cable from the strain relief plate.

Replacement Note: Be sure to secure the video cable onto the strain relief plate before you replace the strain relief plate.





Main Board

Before you begin,

- Remove the rear cover
- Discharge CRT
- Remove the anode cap
- Remove the audio enclosure & speakers
- Remove the video cable

⚠ Warning: This product contains high voltage and a high-vacuum picture tube. To prevent serious injury, review CRT safety in Bulletins/Safety.

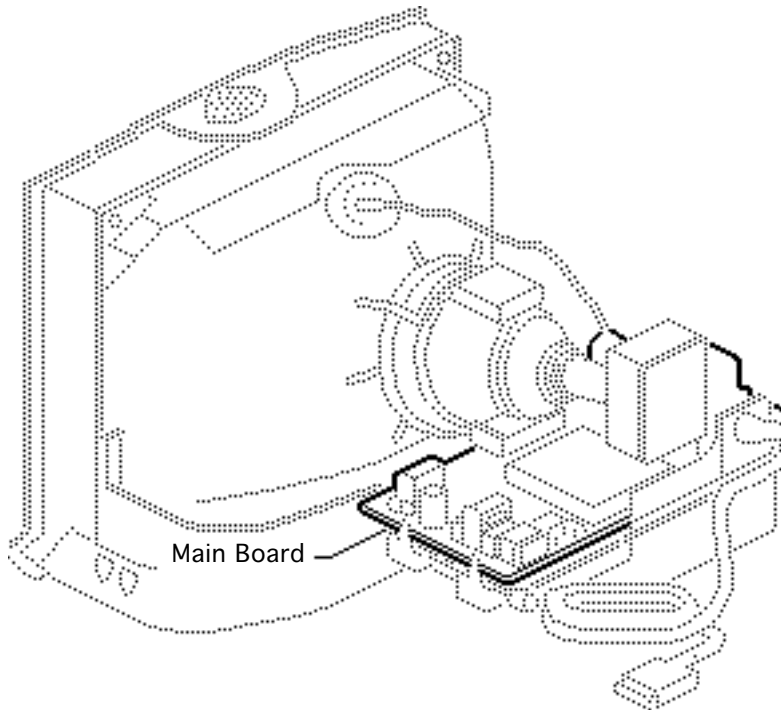

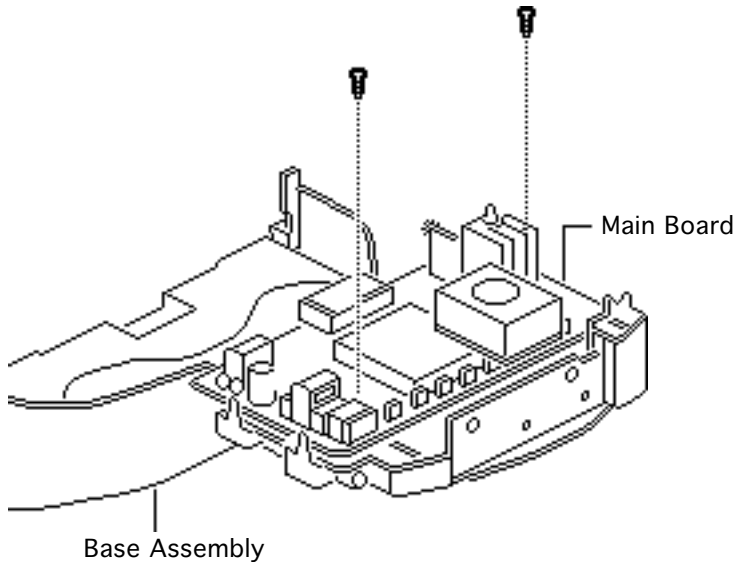

⚠ Warning: Never use a grounding wriststrap until after discharging the CRT.

- 1 Remove the two mounting screws that secure the main board to the base assembly.



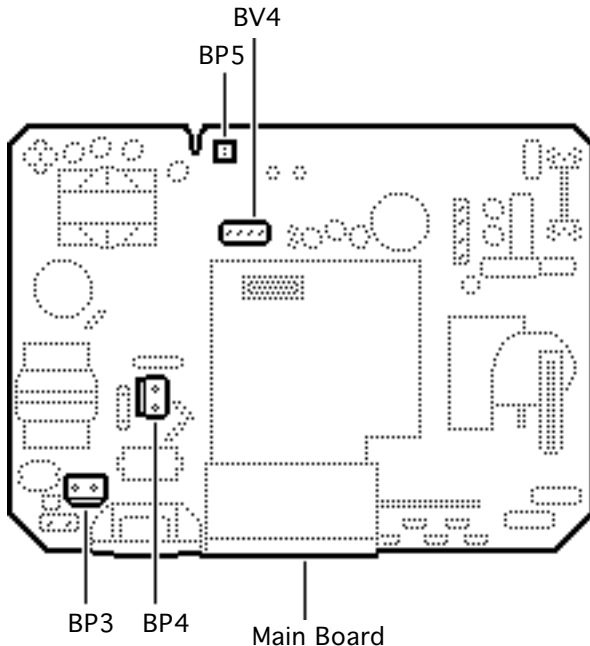

2 Press the release latches and disconnect the following cables from the main board:

- Two-pin, 2-wire on/off switch cable from connector BP3
- Two-pin, 2-wire on/off switch cable from connector BP4
- Two-pin, 2-wire audio cable from connector BP5
- Four-pin, 4-wire audio cable from connector BV4



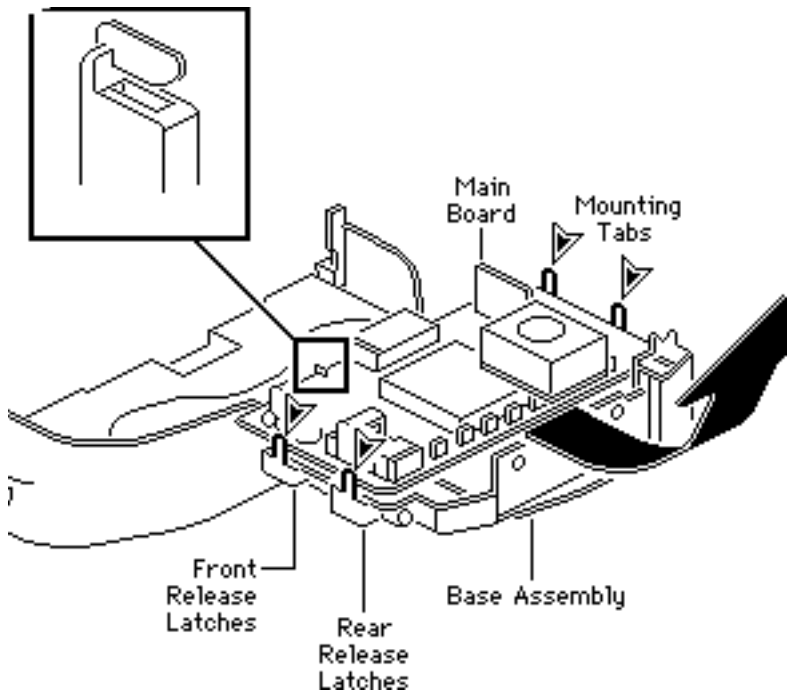

- 3 Push out on the two rear release latches and lift the main board slightly.
- 4 Push out the two front release latches. Lift up and slide the main board back to clear the mounting tabs.
- 5 Remove the main board from the assembly.

Replacement Note: Slide the board under the mounting tabs before you snap the latches into place.





Replacement Note: Perform the cutoff adjustment whenever you replace the main board. See “Video” in the adjustments chapter.





On/Off Switch Assembly

Before you begin,

- Remove the rear cover
- Discharge the CRT
- Remove the anode cap
- Remove the audio enclosure & speakers
- Remove the video cable
- Remove the main board

⚠ Warning: This product contains high voltage and a high-vacuum picture tube. To prevent serious injury, review CRT safety in Bulletins/Safety.

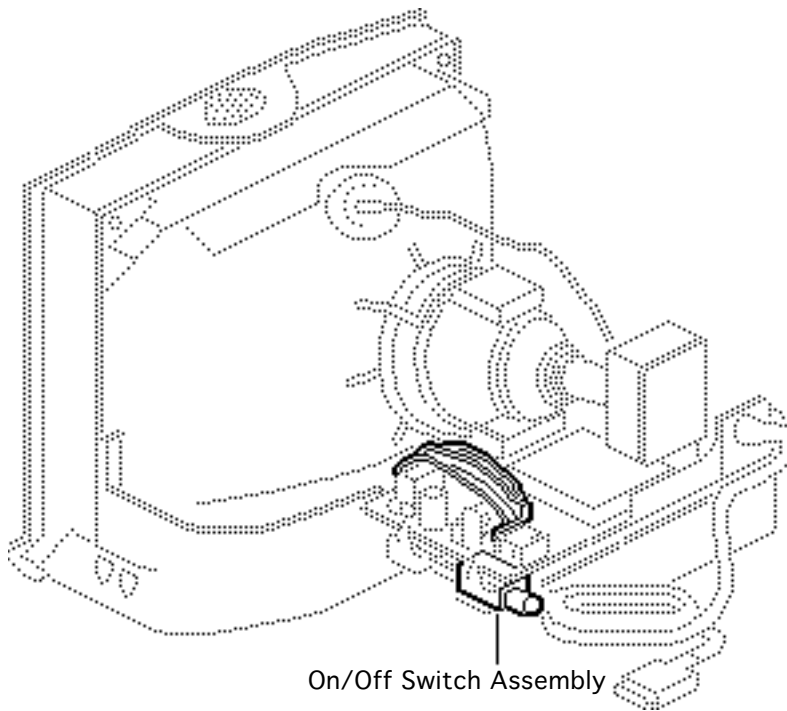

On/Off Switch Assembly



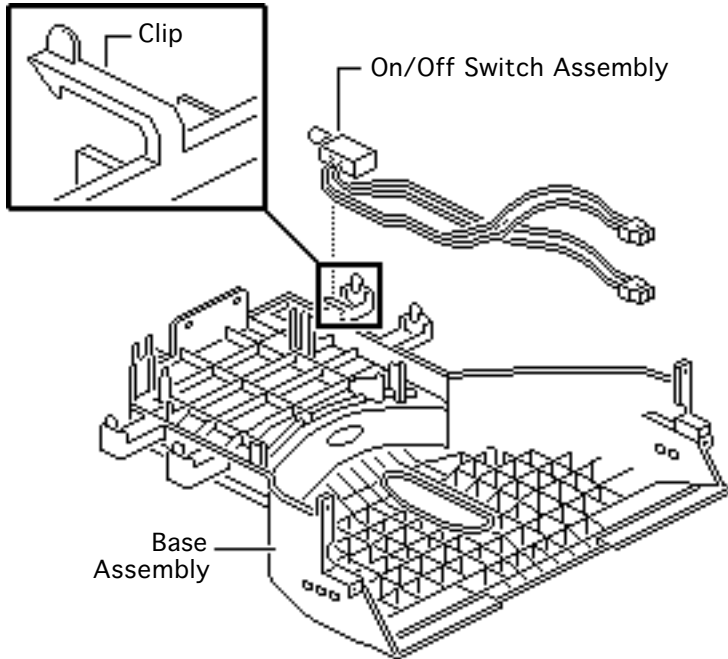

⚠ Warning: Never use a grounding wriststrap until after discharging the CRT.

- 1 Lift the clip and remove the on/off switch assembly from the base assembly.





Monitor Stand

Before you begin,

- Remove the rear cover
- Discharge the CRT
- Remove the anode cap
- Remove the audio enclosure & speakers
- Remove the video cable
- Remove the main board
- Remove the on/off switch assembly

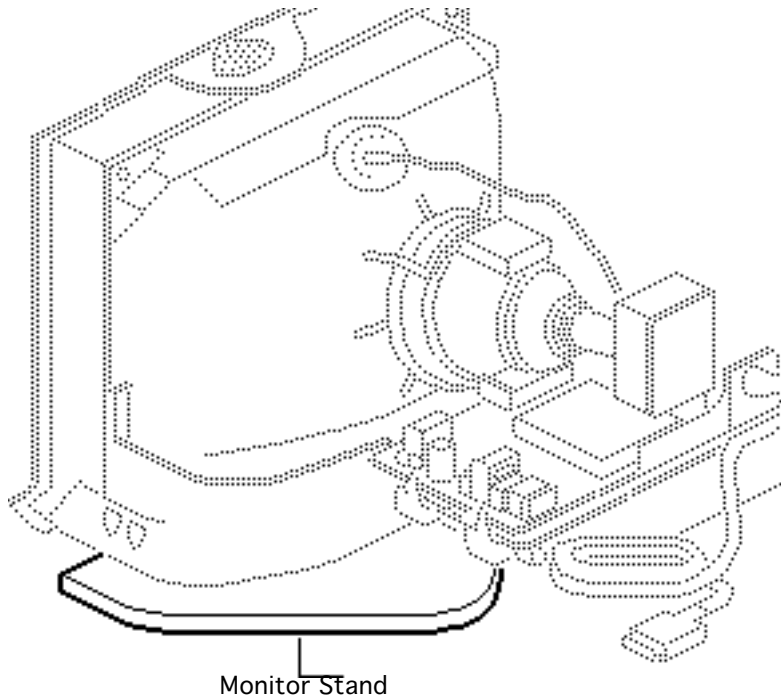

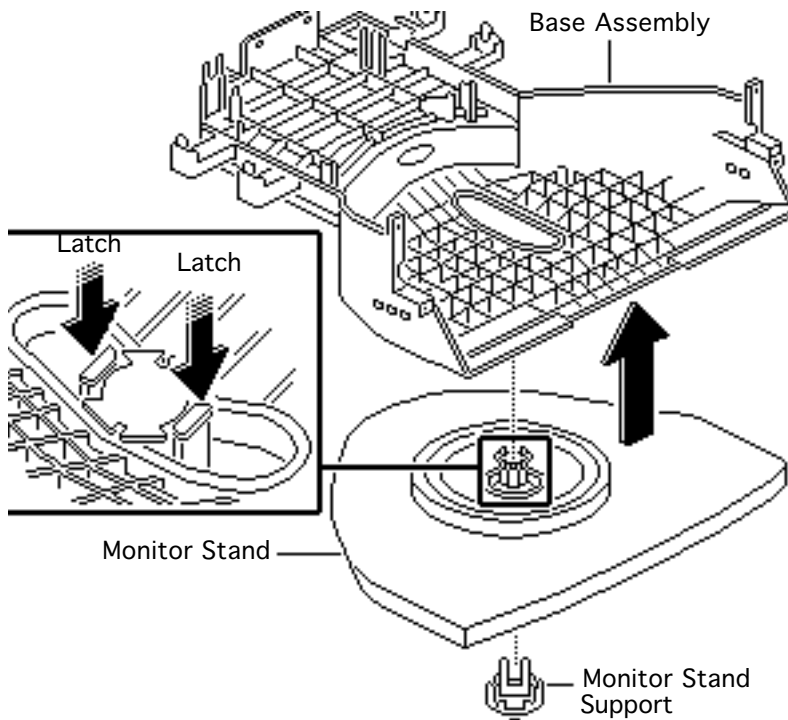

⚠ Warning: This product contains high voltage and a high-vacuum picture tube. To prevent serious injury, review CRT safety in Bulletins/Safety.

⚠ Warning: Never use a grounding wriststrap until after discharging the CRT.

- 1 Swivel the base assembly to align the monitor stand support latches with the opening of the base assembly. Press down on the two monitor stand support latches.



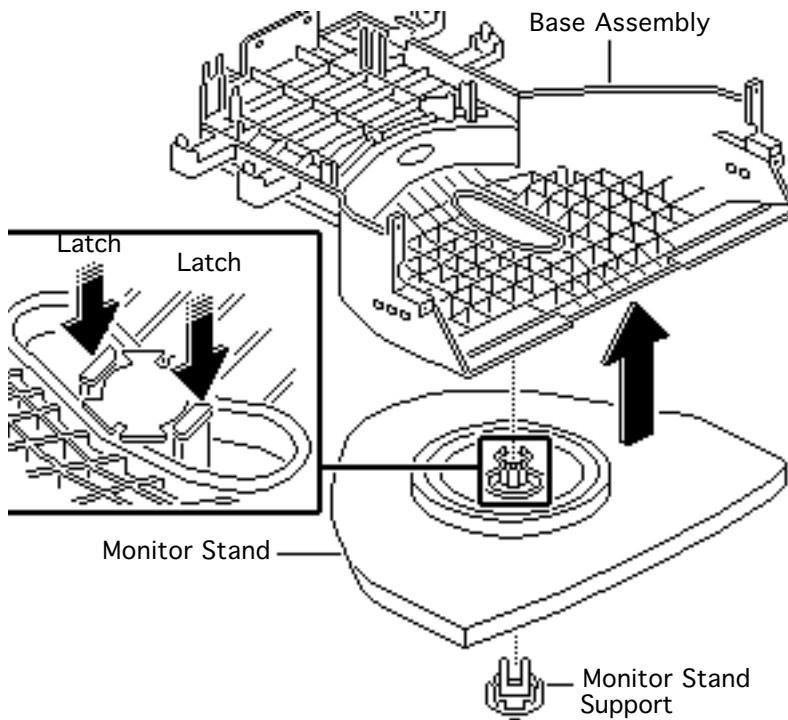

- 2 Hold up the base assembly and monitor stand. Press down on the two monitor stand support latches and pull off the monitor stand support.
- 3 Turn the base assembly and remove the monitor stand.





Base Assembly

Before you begin,

- Remove the rear cover
- Discharge the CRT
- Remove the anode cap
- Remove the audio enclosure & speakers
- Remove the video cable
- Remove the main board
- Remove the on/off switch assembly
- Remove the monitor stand

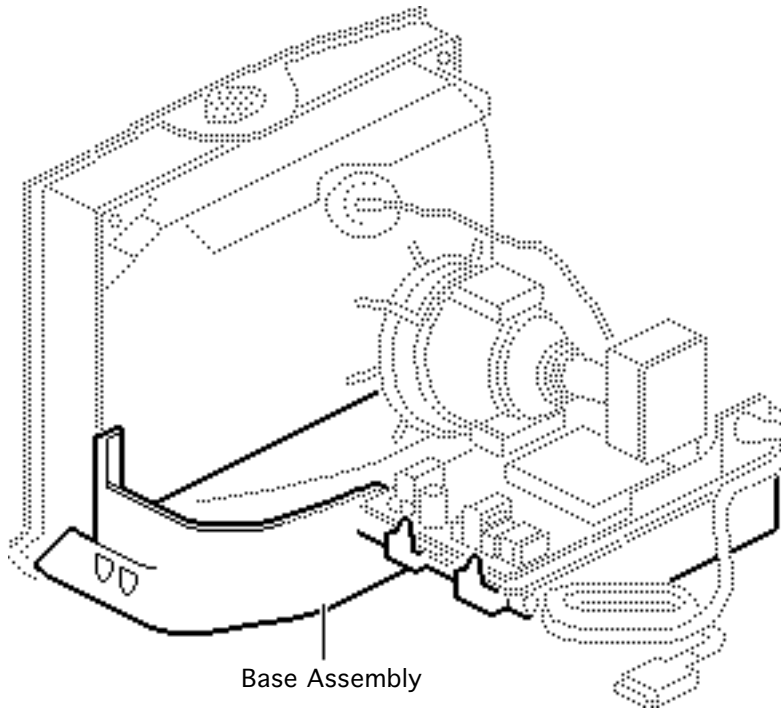

Base Assembly



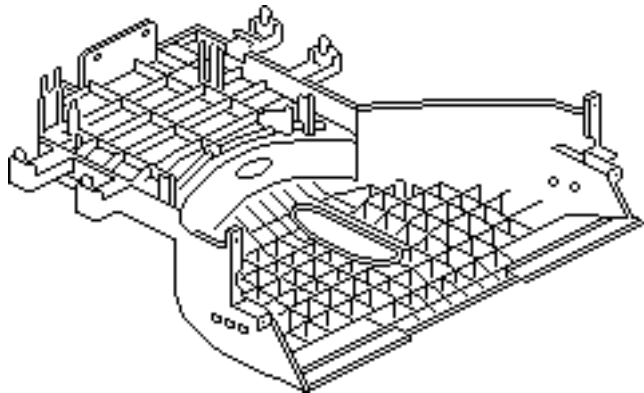

⚠ Warning: This product contains high voltage and a high-vacuum picture tube. To prevent serious injury, review CRT safety in Bulletins/Safety.

⚠ Warning: Never use a grounding wriststrap until after discharging the CRT.

Complete all the steps on the previous page.





Front Panel Controls & LEDs

Before you begin,

- Remove the rear cover
- Discharge the CRT
- Remove the anode cap

⚠ Warning: This product contains high voltage and a high-vacuum picture tube. To prevent serious injury, review CRT safety in Bulletins/Safety.

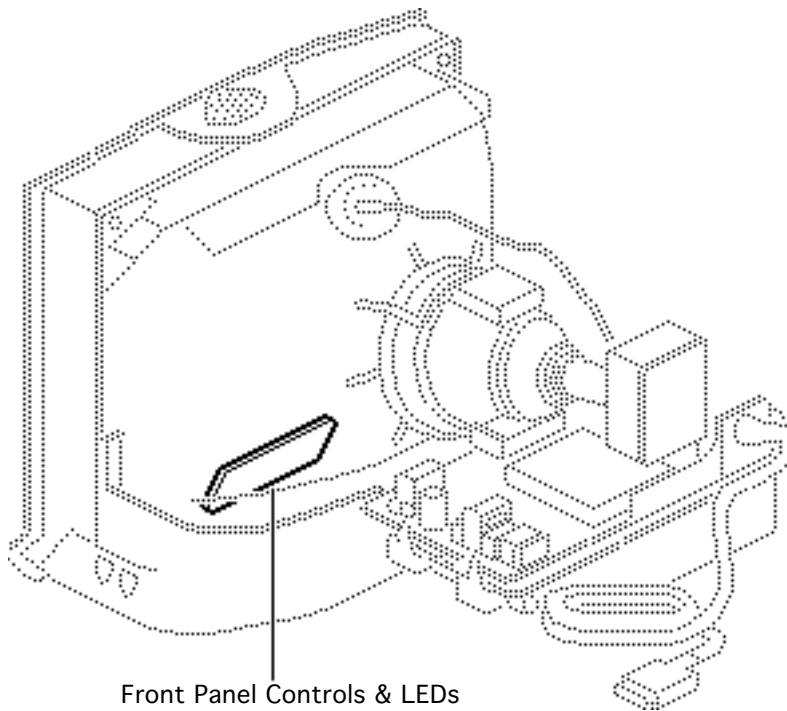

Front Panel Controls & LEDs



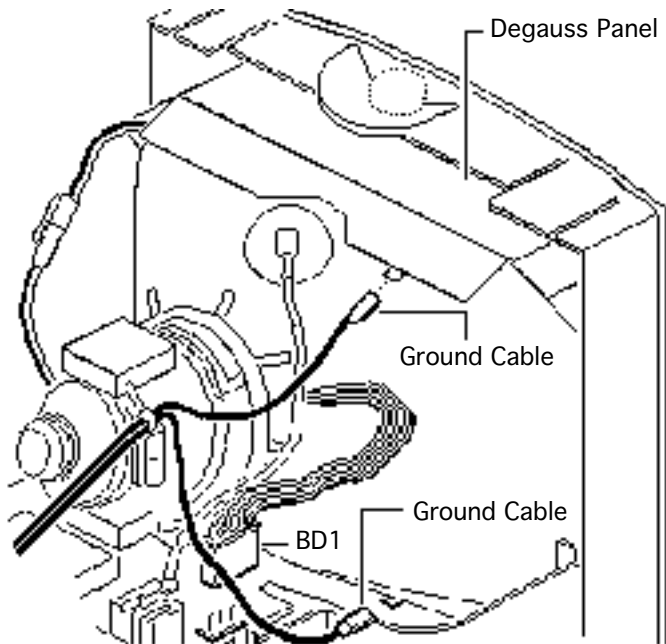

⚠ Warning: Never use a grounding wriststrap until after discharging the CRT.

- 1 Cut the tie wrap and disconnect the two ground cables from the degauss panels and the 4-pin, 4-wire CRT cable from connector BD1.



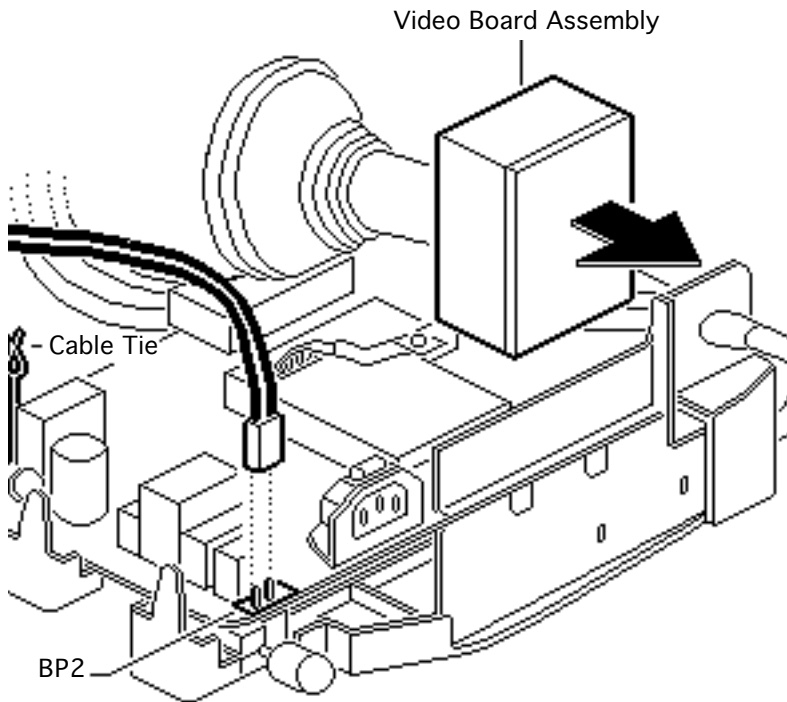

- 2 **Caution:** Twisting, bending, or applying force to the video board assembly could damage the neck of the CRT. Be sure to pull the video board assembly straight off the CRT.

Remove the video board assembly from the neck of the CRT.

- 3 Cut the tie wrap that connects cables BP2 and BP3.
- 4 Undo the cable tie that connects cables BP2 and BP4.



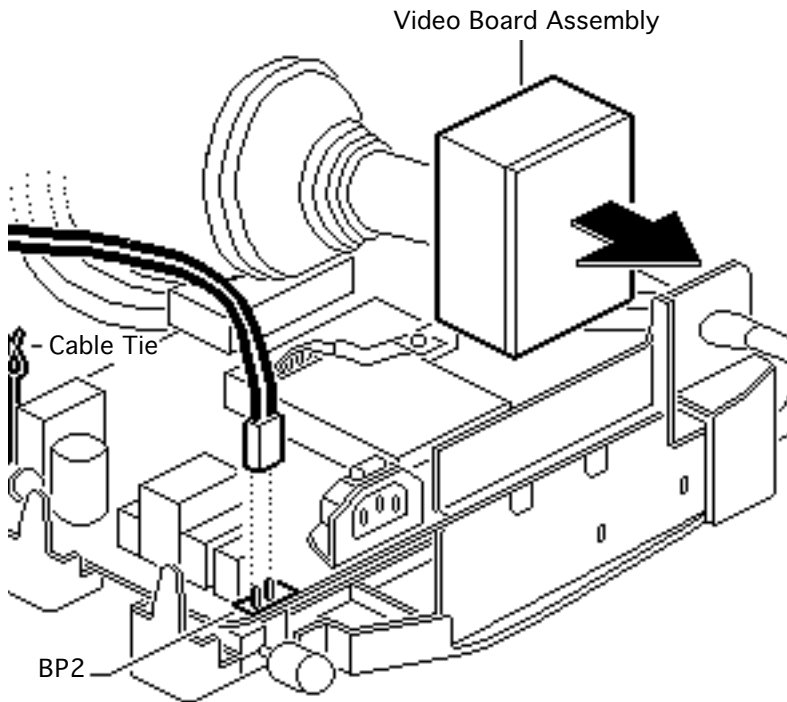

- 5 Disconnect the degauss cable from connector BP2.



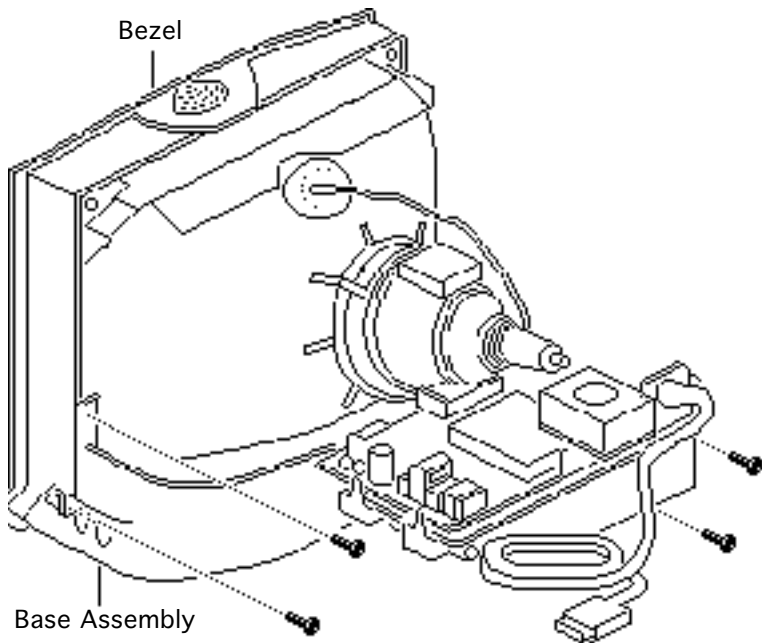

- 6 Remove the four screws that secure the base assembly to the bezel.

Replacement Caution:
Do not overtighten the four screws.



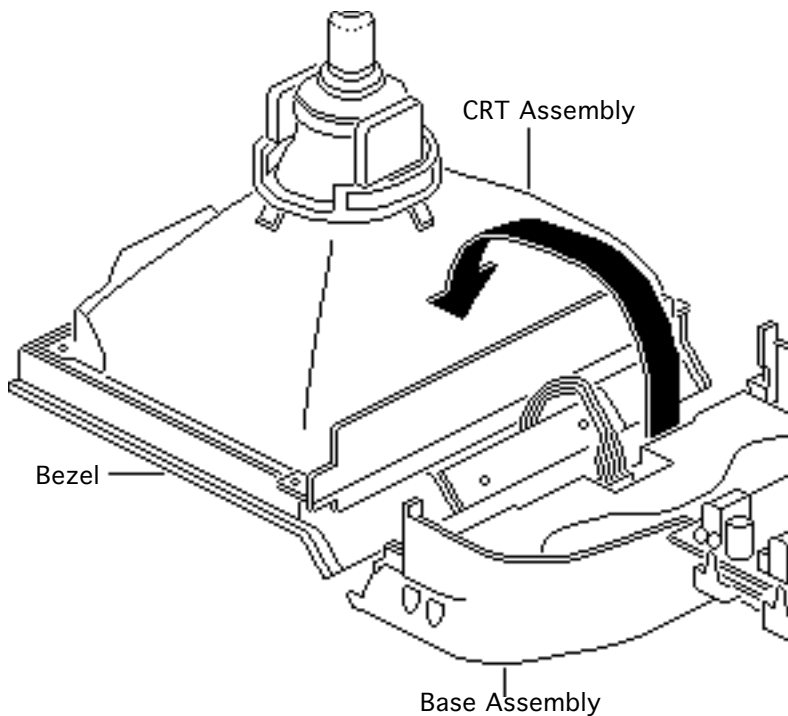

- 7 Carefully lower the front of the monitor until it lies face-down on the workbench.



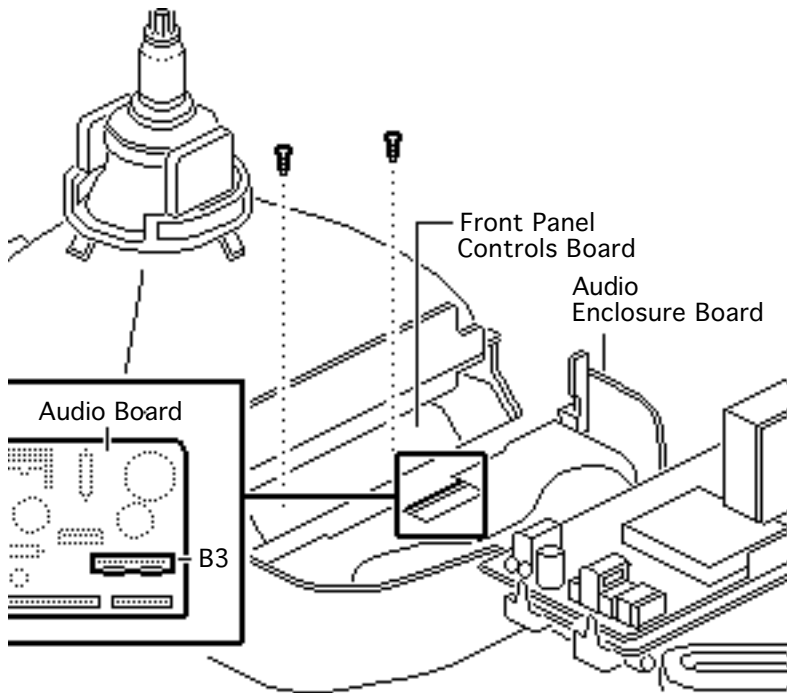

- 8 Disconnect the cable from connector B3 on the audio enclosure board.
- 9 Using a T-10 torx driver, remove the two screws that secure the front panel controls board to the bezel.





10 Remove the front panel controls board.

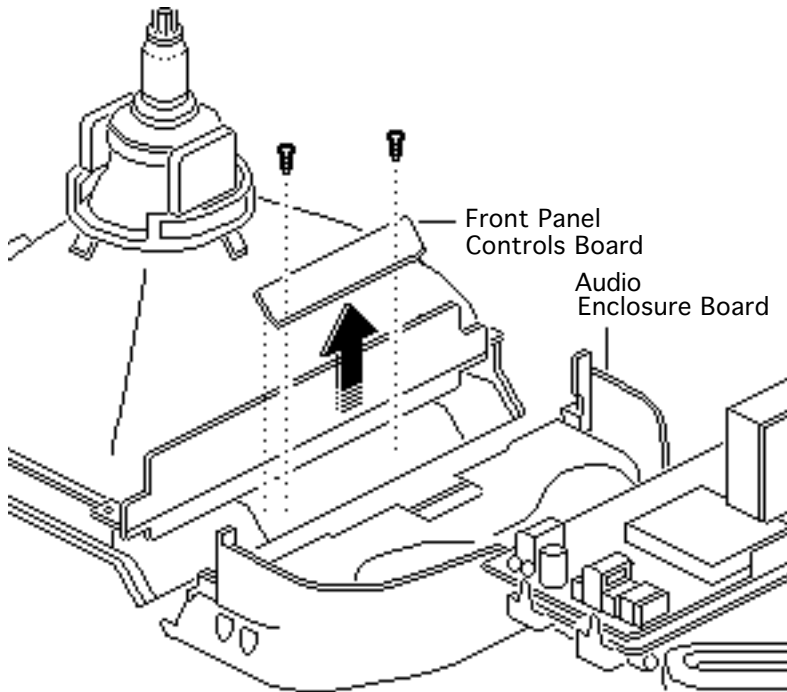



CRT Assembly

Before you begin,

- Remove the rear cover
- Discharge the CRT
- Remove the anode cap

⚠ Warning: This product contains high voltage and a high-vacuum picture tube. To prevent serious injury, review CRT safety in Bulletins/Safety.

⚠ Warning: Never use a grounding wriststrap until after discharging the CRT.

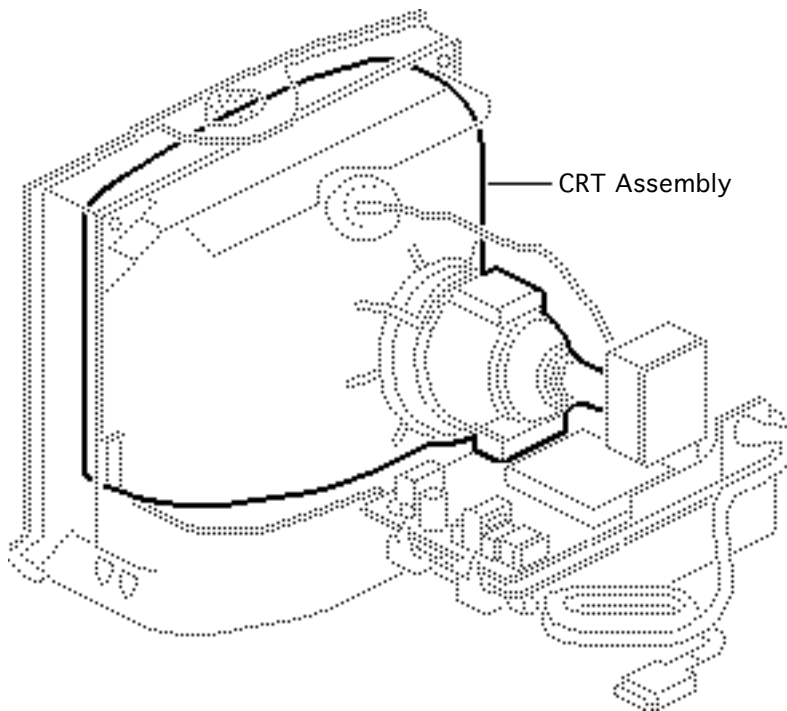

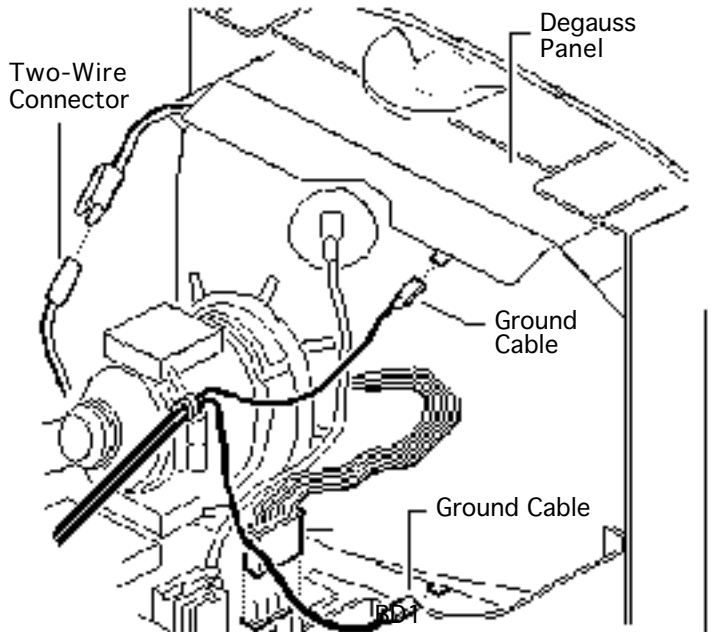

- 1 Cut the tie wrap and disconnect the two ground cables from the degauss panels and the 4-pin, 4-wire CRT cable from connector BD1.
- 2 Disconnect the two-wire (black/white) cable.



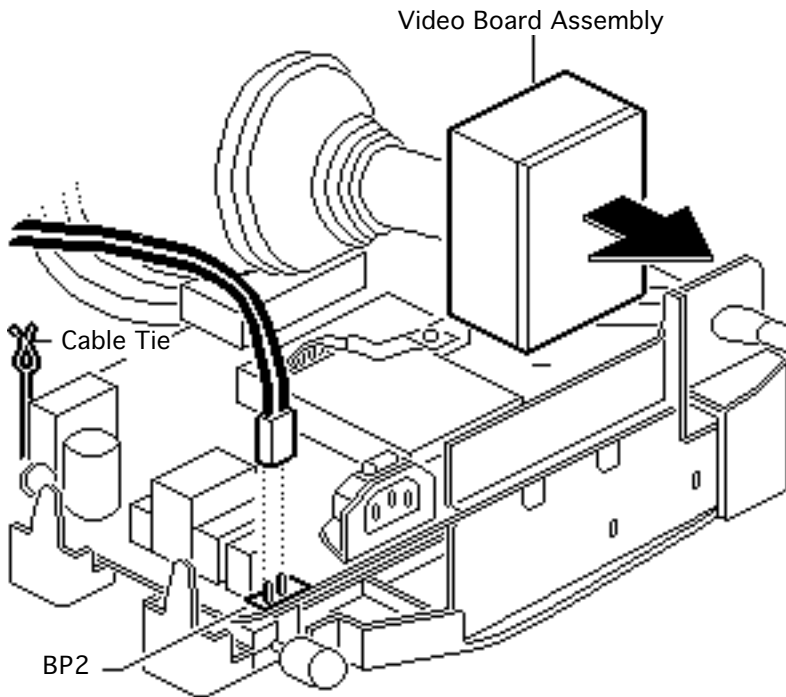

- 3 **Caution:** Twisting, bending, or applying force to the video board assembly could damage the neck of the CRT. Be sure to pull the video board assembly straight off the CRT.

Remove the video board assembly from the neck of the CRT.

- 4 Cut the tie wrap that connects cables BP2 and BP3.
- 5 Undo the cable tie that connects cables BP2 and BP4.



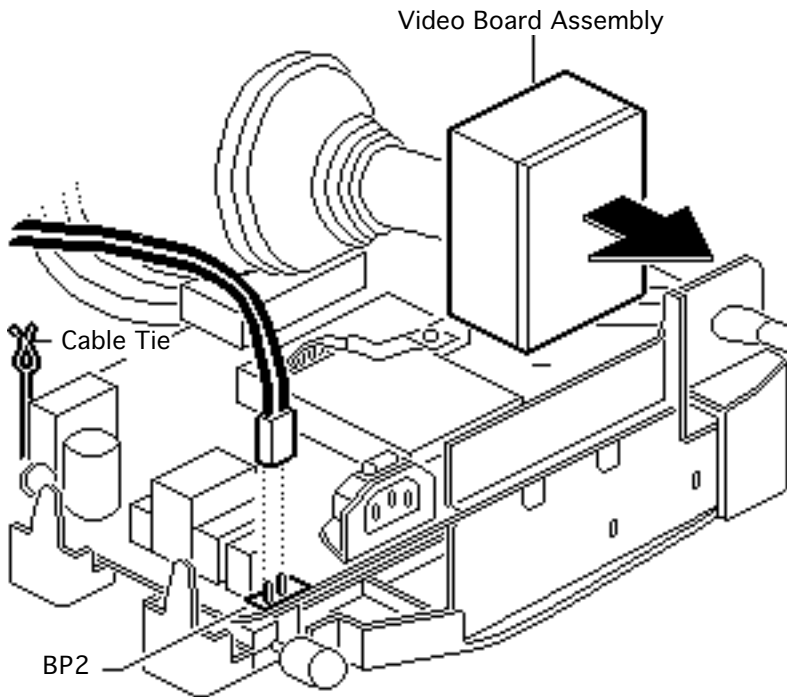

- 6 Disconnect the degauss cable from connector BP2.





- 7 Remove the four screws that secure the base assembly to the bezel.

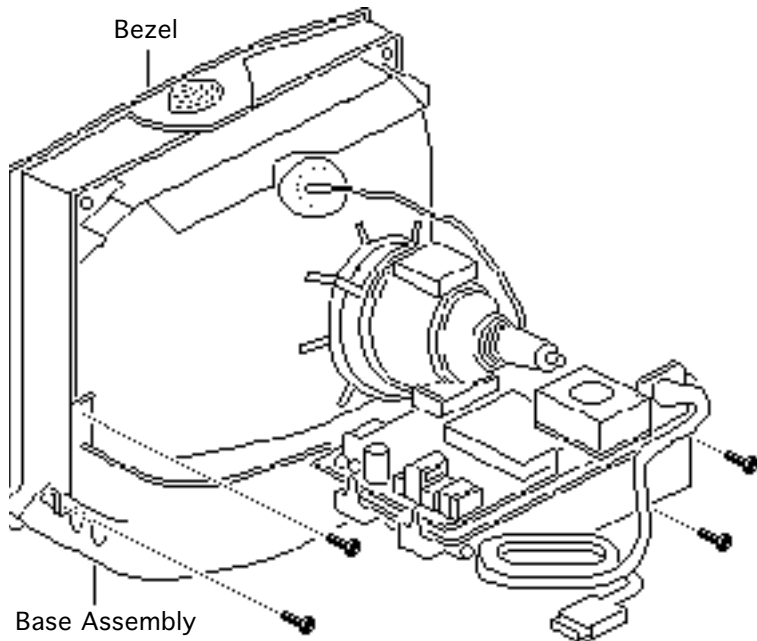

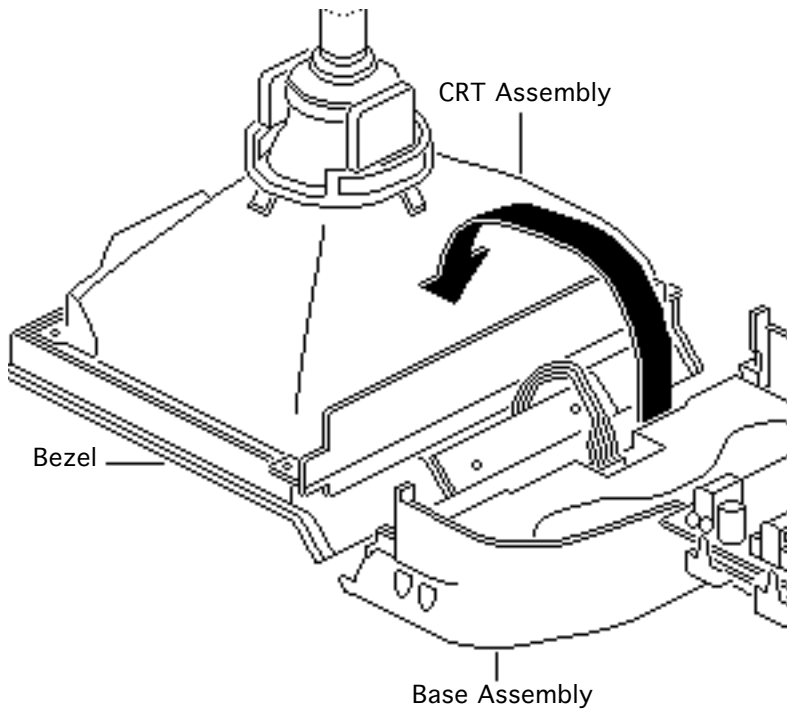

- 8 Carefully lower the front of the monitor until it lies face-down on the workbench.





Microphone Assembly Clip

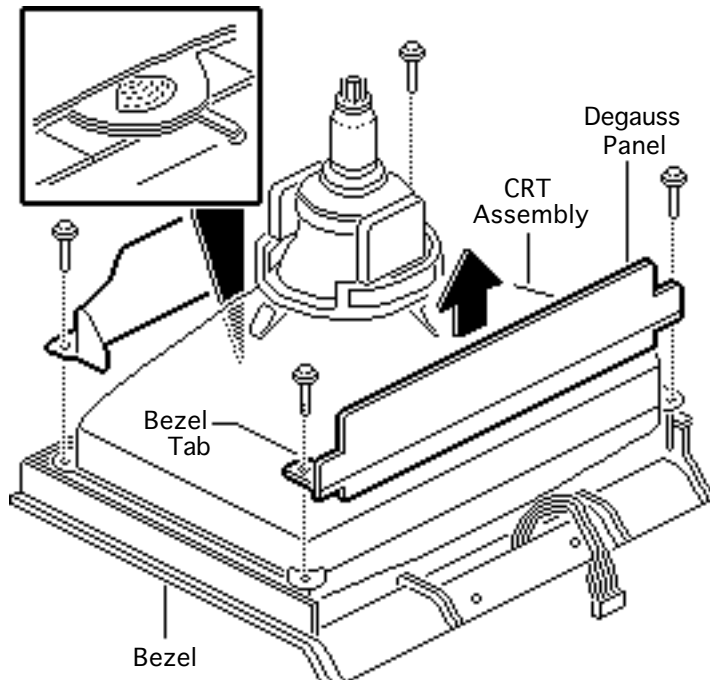

- 9 Remove the four self-threading bolts that secure the degauss panels and CRT to the bezel.
- 10 Push the top degauss panel towards the CRT and release the microphone assembly clip.
- 11 Remove the degauss panels.

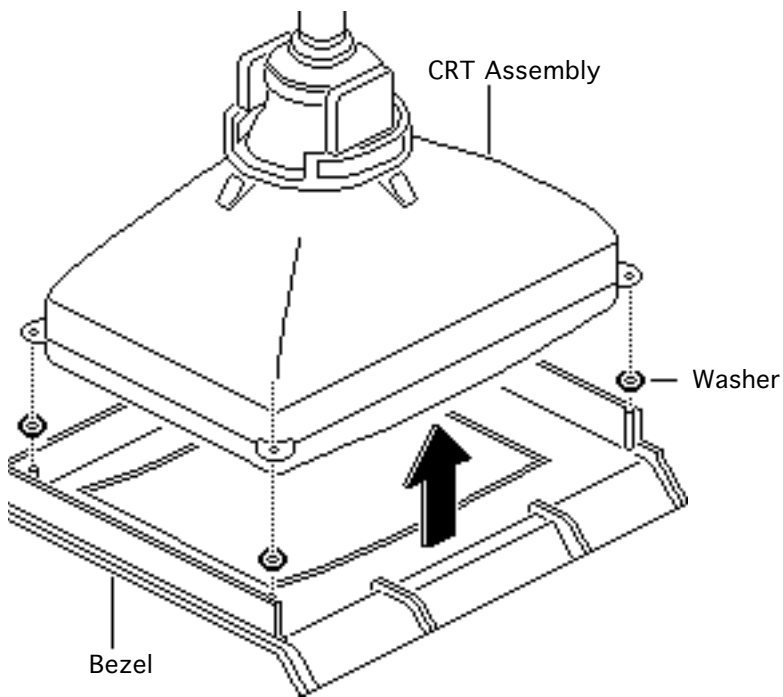

**Replacement Note:**

When replacing the top degauss panel, make sure the microphone assembly clip is attached to the panel and the two bezel tabs are inserted into the holes.

- 12 Carefully lift the CRT assembly out of the bezel.

Replacement Note:

Replace the washers between the CRT and the bezel if they are damaged or missing.





Microphone Assembly

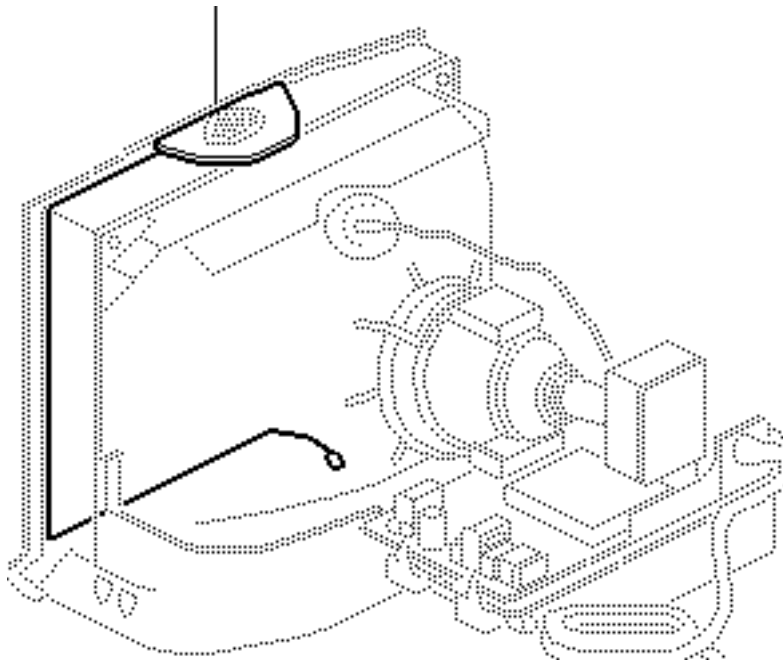

Microphone Assembly

Before you begin,

- Remove the rear cover
- Discharge the CRT
- Remove the anode cap
- Remove the CRT assembly

⚠ Warning: This product contains high voltage and a high-vacuum picture tube. To prevent serious injury, review CRT safety in Bulletins/Safety.



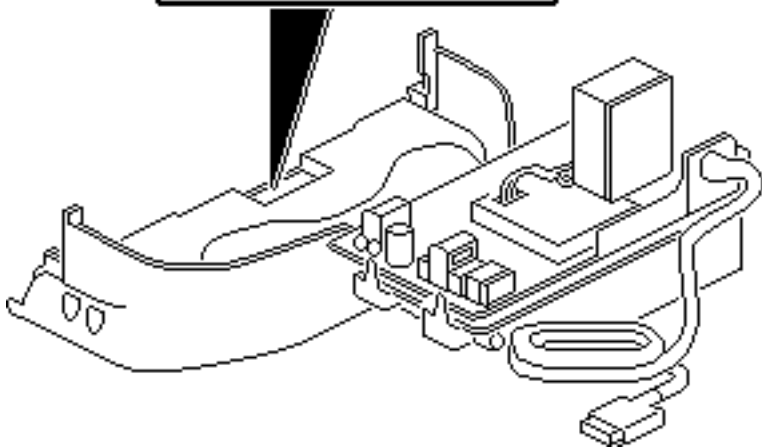
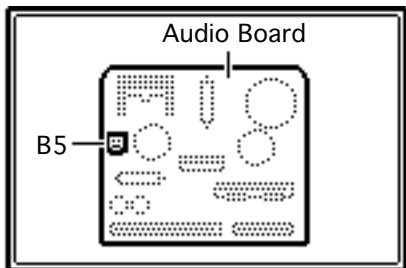

⚠ Warning: Never use a grounding wriststrap until after discharging the CRT.

- 1 Disconnect the microphone cable from connector B5 on the audio board.



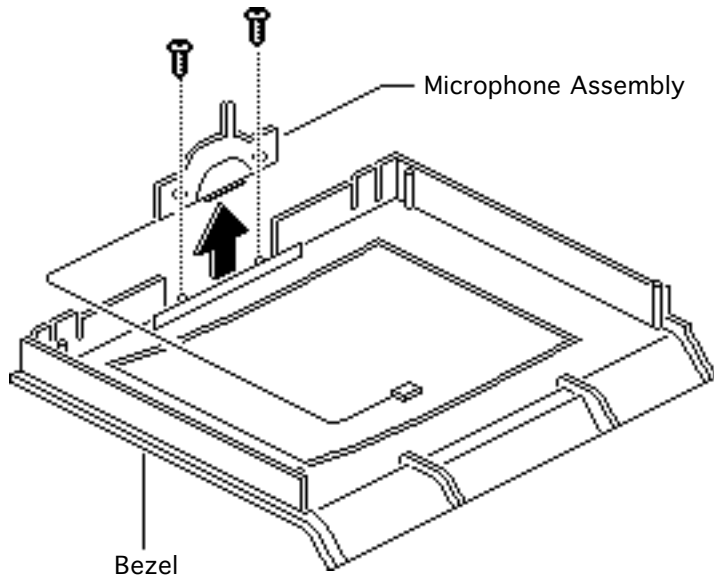

- 2 Remove the microphone cable from its guides along the bezel.
- 3 Using a T-20 torx driver, remove the two screws that secure the microphone assembly to the bezel.
- 4 Remove the microphone assembly.



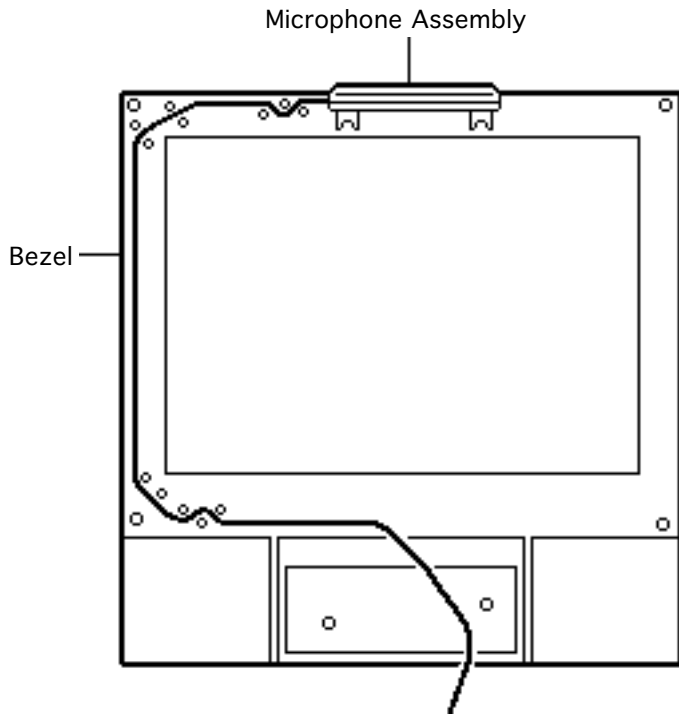

Replacement Caution:
When reattaching the bezel to the base assembly, be careful not to pinch the microphone assembly cable.



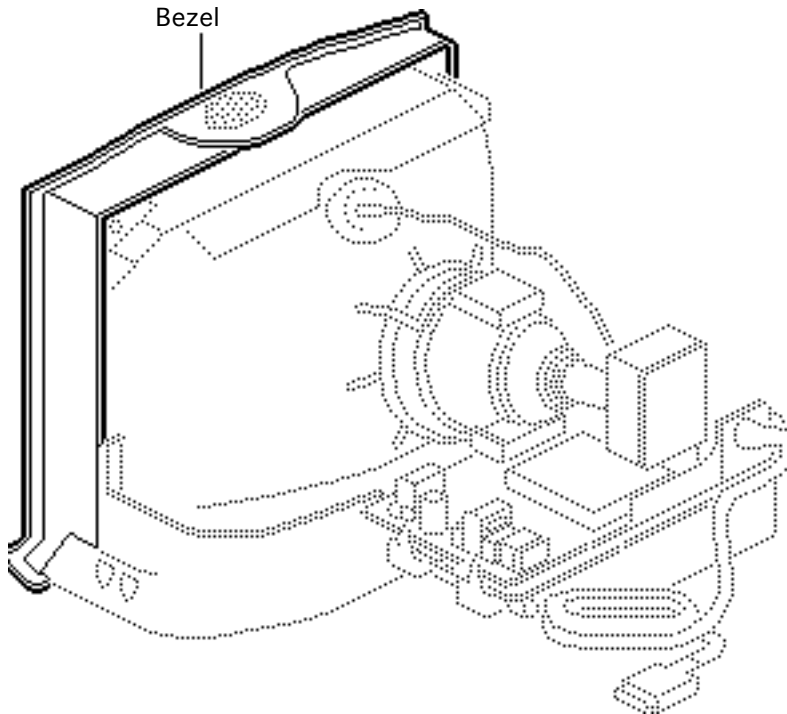

Bezel

Before you begin,

- Remove the rear cover
- Discharge the CRT
- Remove the anode cap
- Remove the front panel controls & LEDs
- Remove the CRT assembly
- Remove the microphone assembly

⚠ Warning: This product contains high voltage and a high-vacuum picture tube. To prevent serious injury, review CRT safety in Bulletins/Safety.



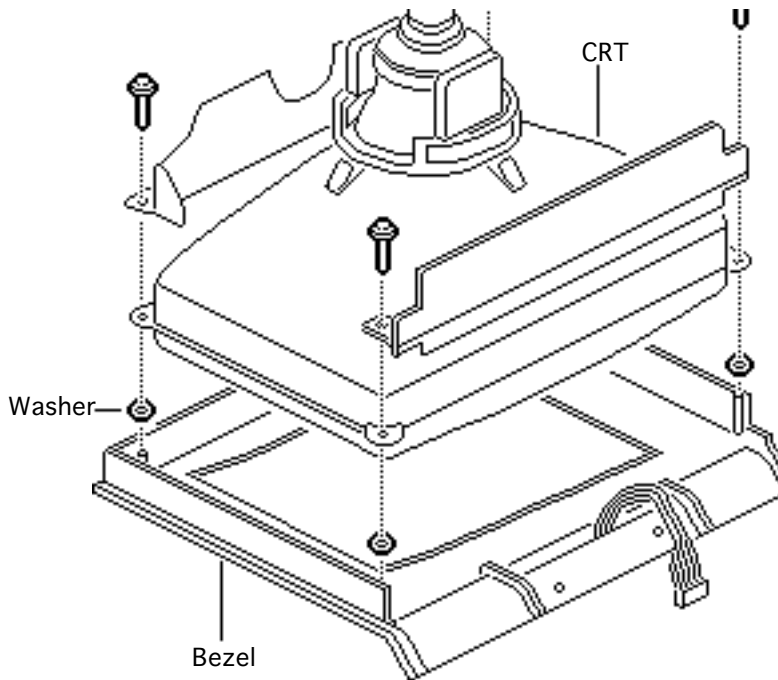

⚠ Warning: Never use a grounding wriststrap until after discharging the CRT.

Complete all the steps on the previous page.

Replacement Note: Install the four washers included with the new bezel.



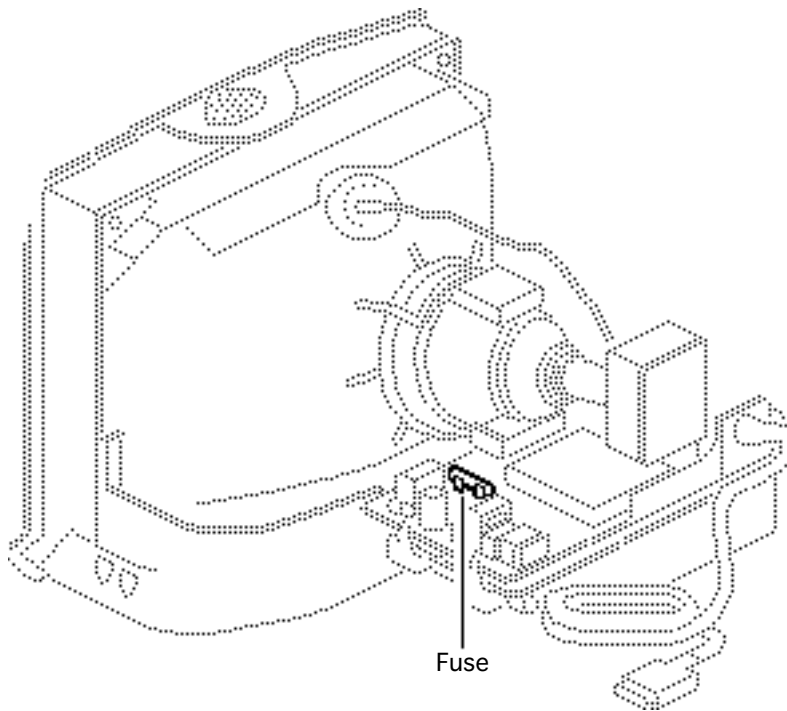

Fuse

Before you begin,

- Remove the rear cover
- Discharge the CRT
- Remove the anode cap

⚠ Warning: This product contains high voltage and a high-vacuum picture tube. To prevent serious injury, review CRT safety in Bulletins/Safety.

⚠ Warning: Never use a grounding wriststrap until after discharging the CRT.



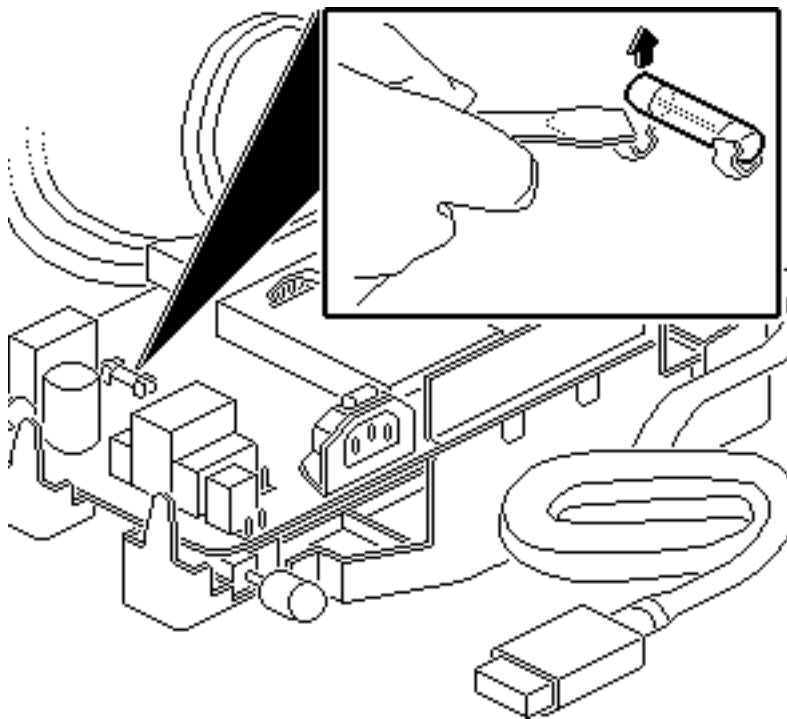

Using a small, long-stemmed screwdriver, pry up one end of the fuse and remove it from the main board.





Adjustments

Apple AudioVision 14 Display



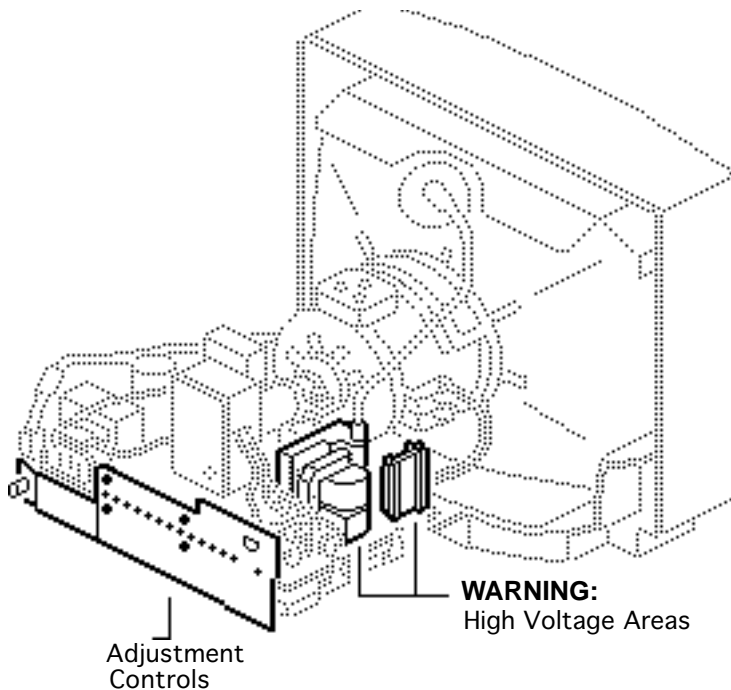

Geometry

Before you begin, remove the rear cover.

⚠ Warning: This product contains high voltage and a high-vacuum picture tube. To prevent serious injury, review CRT safety in Bulletins/Safety.





Note: The controls on this monitor require a small hex-head plastic tool to make adjustments. If the tool is long, it will be too flexible, which will make fine adjustments difficult. Use a short hex-head plastic tool to minimize flexing. Do not use metal alignment tools—they are a shock hazard.

Caution: Adjustments should be performed only after a 15-minute warm-up period.



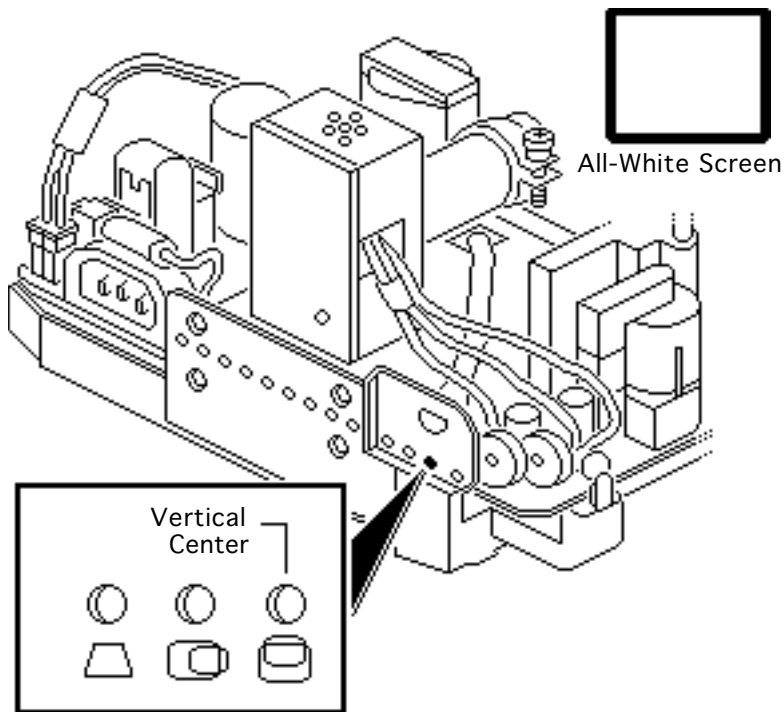

Vertical Center

- 1 Use Display Service Utility to display the All-White Screen test pattern.
- 2 Using a hex-head plastic adjustment tool, adjust the vertical center control until the raster is centered (top to bottom) in the display area.



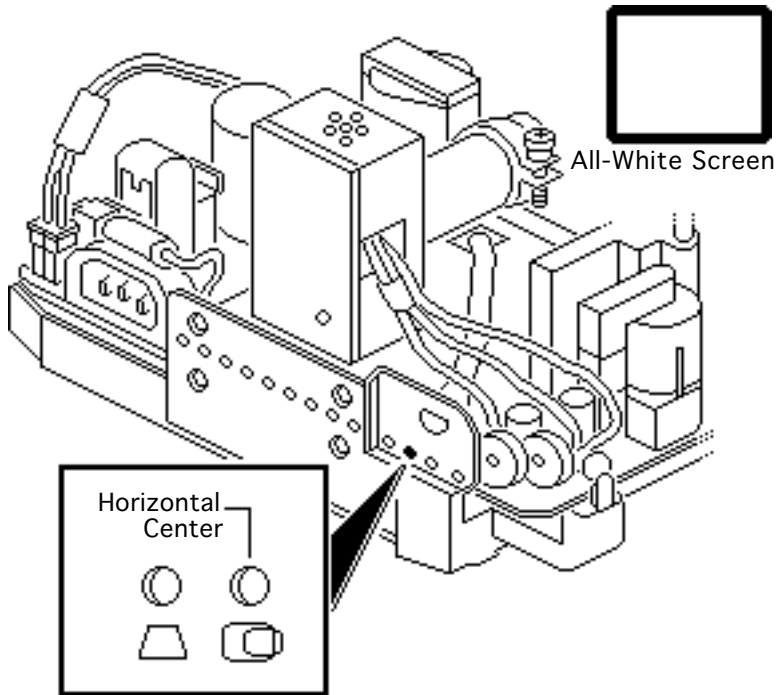

Horizontal Center

Using a hex-head plastic adjustment tool, adjust the horizontal center control until the raster is centered (side to side) in the display area.



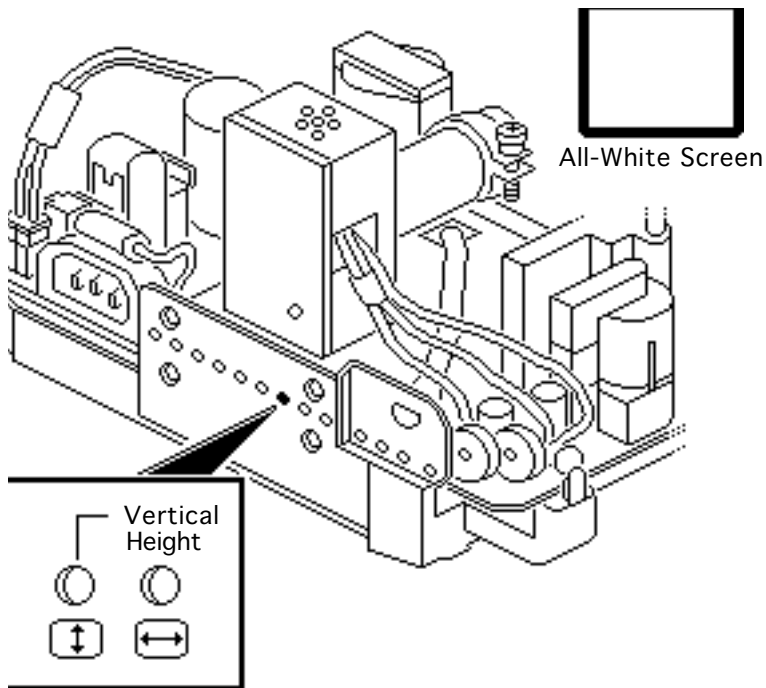

Vertical Size

- 1 Using a hex-head plastic adjustment tool, adjust the vertical height control until the raster height is 7 in. ($\pm 1/8$ in.) or 176 mm (± 2 mm).
- 2 Verify this height. If it is off, repeat the vertical size adjustment and, if necessary, the vertical center adjustment.



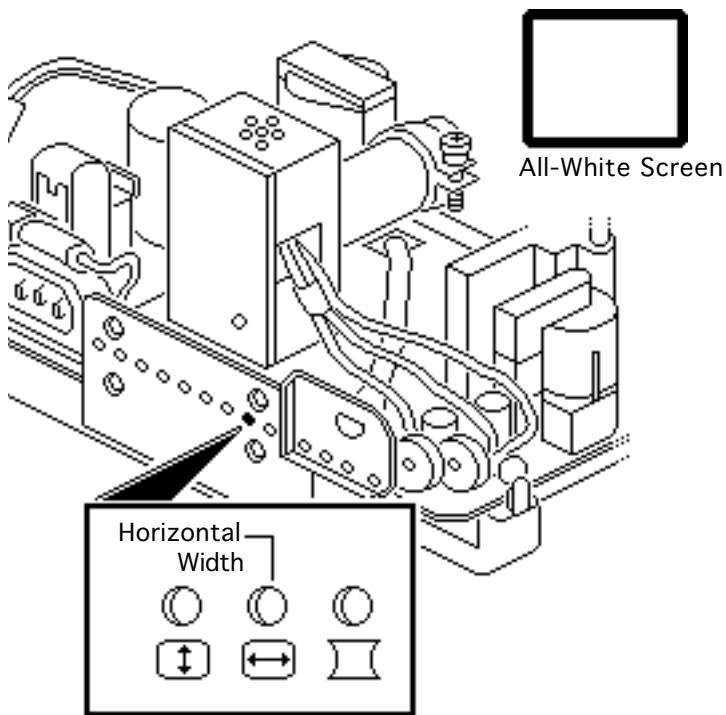

Horizontal Size

Note: Due to video features and timing differences across the Apple line of Macintosh computers, the width of the raster/image area on the AudioVision 14-Inch Display may vary up to $3/16$ inch at each side of the display. Perform the horizontal size adjustment to set the display to its proper width.





Using a hex-head plastic adjustment tool, adjust the horizontal width control until the raster is $9 \frac{1}{4}$ in. ($\pm 1/8$ in.) or 235 mm (± 2 mm).



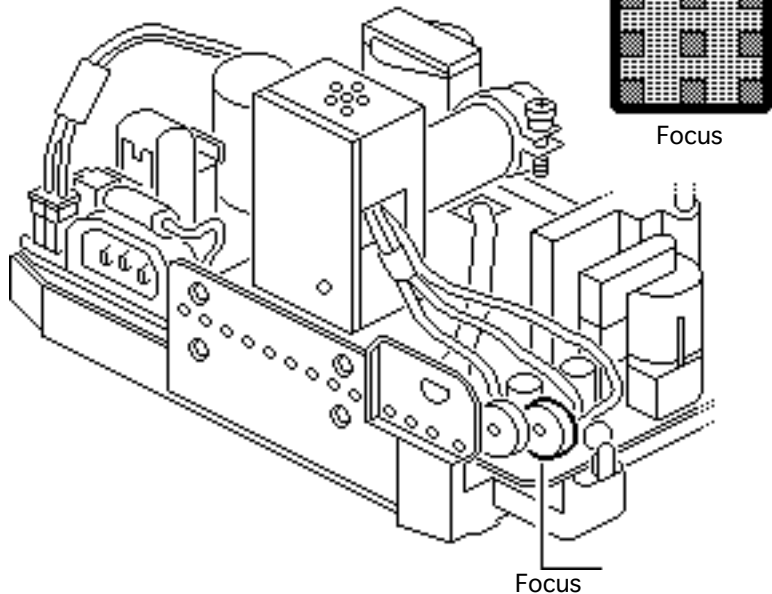

Focus

- 1 Use Display Service Utility to display the Focus test pattern.
- 2 Using a hex-head plastic adjustment tool, adjust the focus control until the Focus test pattern is as clear as possible.





Video

Before you begin, remove the rear cover.

⚠ Warning: This product contains high voltage and a high-vacuum picture tube. To prevent serious injury, review CRT safety in Bulletins/Safety.

Note: Perform the cutoff adjustment prior to adjusting the white balance.

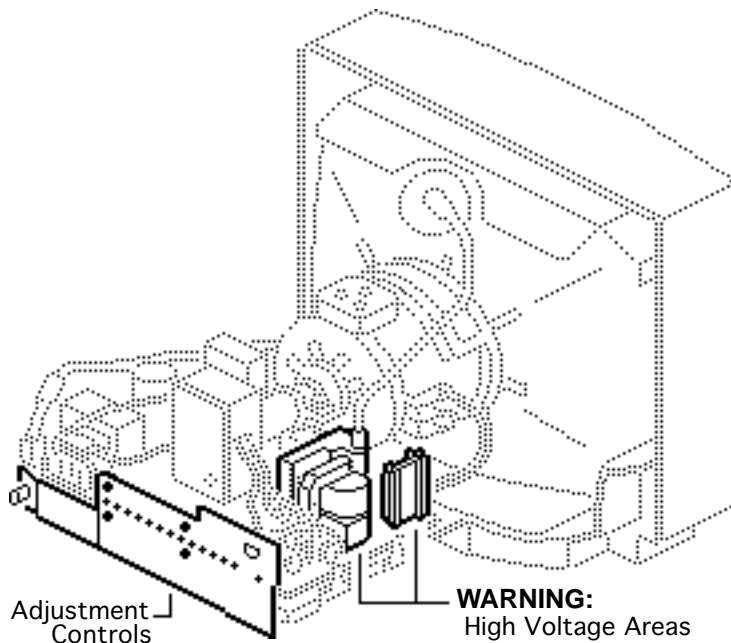



Replacement Note: Perform the cutoff adjustment whenever you replace the CRT assembly or the main board.



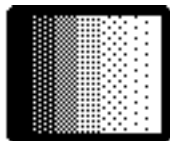
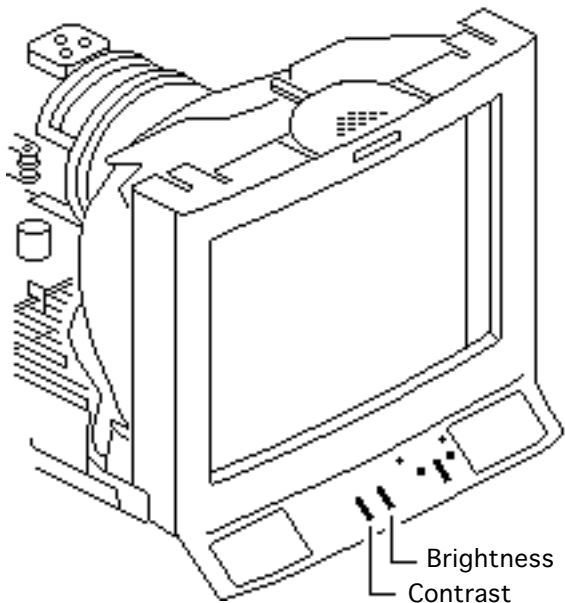

Gray Bars

Cutoff

Note: Perform the cutoff and white balance adjustments after the monitor has been on for at least 10 minutes.

- 1 Use Display Service Utility to display the Gray Bars test pattern.
- 2 Set the contrast control to maximum contrast and the brightness control to a medium brightness level.



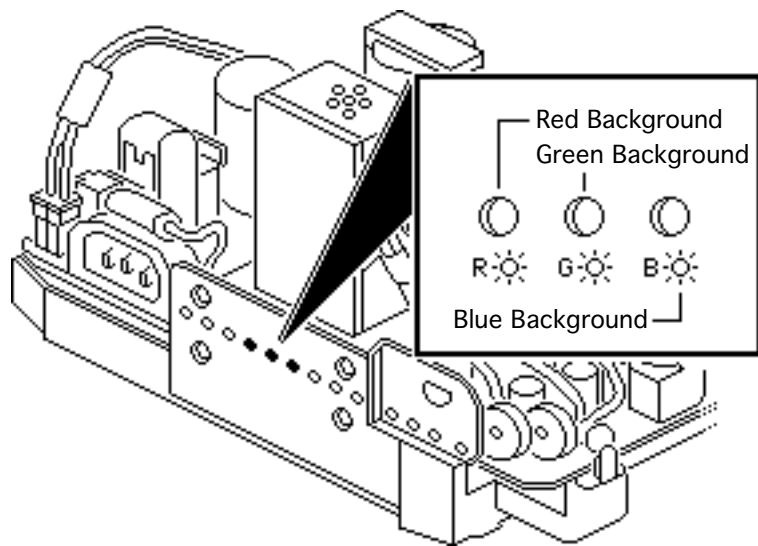

- Using a hex-head plastic adjustment tool, set the red, green, and blue background controls to full counterclockwise positions.



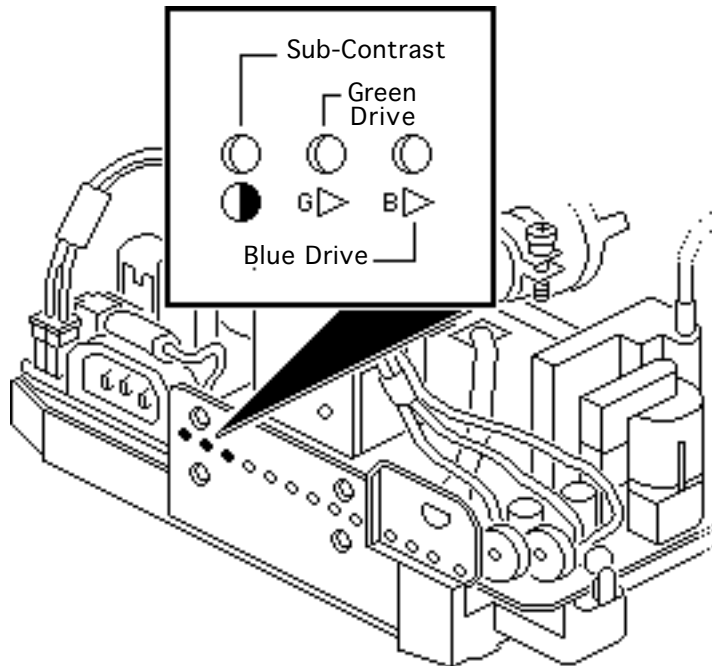

Note: To set the green and blue drive controls to their 3/4 position, turn the controls to their full clockwise position and then turn back 1/4 turn counterclockwise.

- 4 Set the green and blue drive controls clockwise to their 3/4 position.
- 5 Set the sub-contrast control to its full clockwise position.



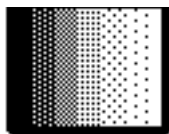

Gray Bars

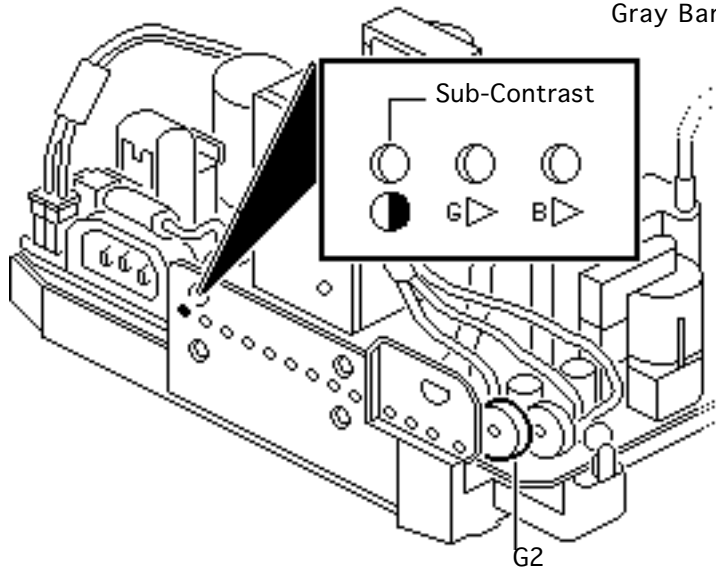

- 6 Using a hex-head plastic adjustment tool, adjust G2 until the first bar in the test pattern is completely black and the second bar is barely visible.
- 7 Set the sub-contrast control to the center position.



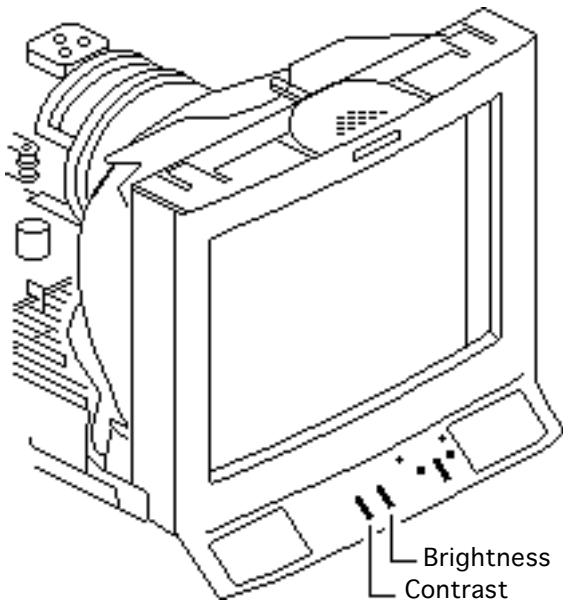

White Balance

- 1 **Note:** Perform the cutoff and white balance adjustments after the monitor has been on for at least 10 minutes.
- 2 Use Display Service Utility to display the Gray Bars test pattern.
- 3 Set the contrast control to maximum contrast and the brightness control to a medium brightness level.



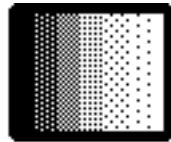

Gray Bars

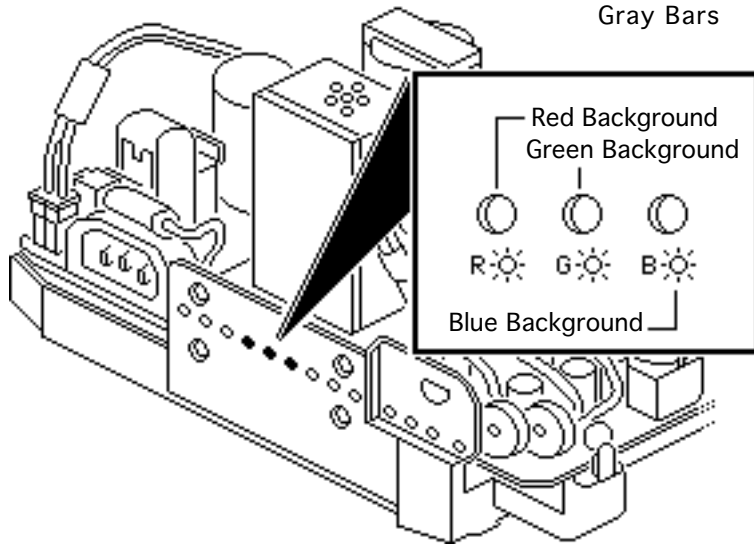

- 4 Note the predominant color.
- 5 Using a hex-head plastic adjustment tool, alternately adjust the red, green, and blue background controls until there is no predominant color in the four darkest bars.





Note: The darkest bar must remain completely black throughout the rest of the procedure. If you notice a predominant color in the darkest bar, readjust the appropriate background control.



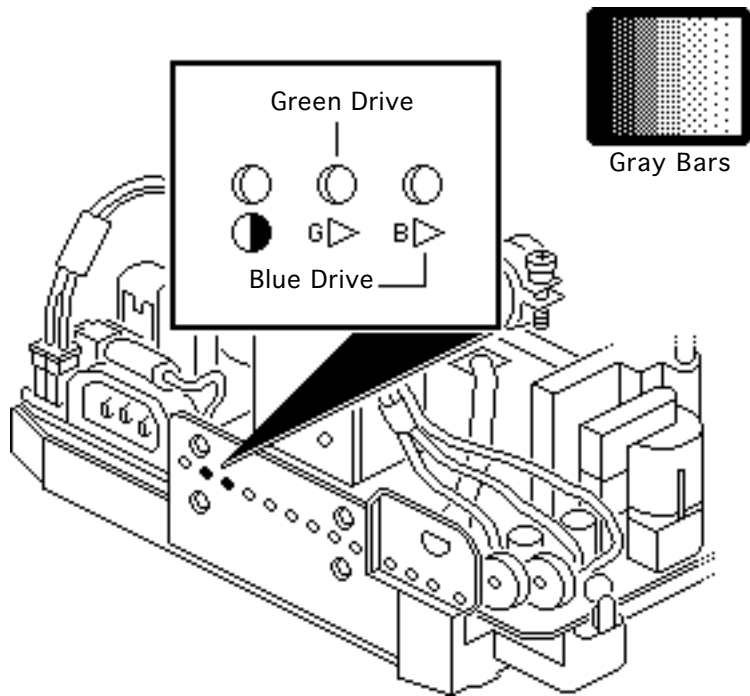

- 6 If necessary, adjust the blue and green drive controls until there is no predominant color in the four brightest bars.



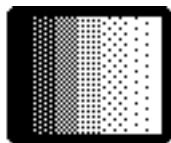

Gray Bars

- 7 Check the four darkest bars, and if necessary, adjust the red, green, and blue background controls until there is no predominant color.

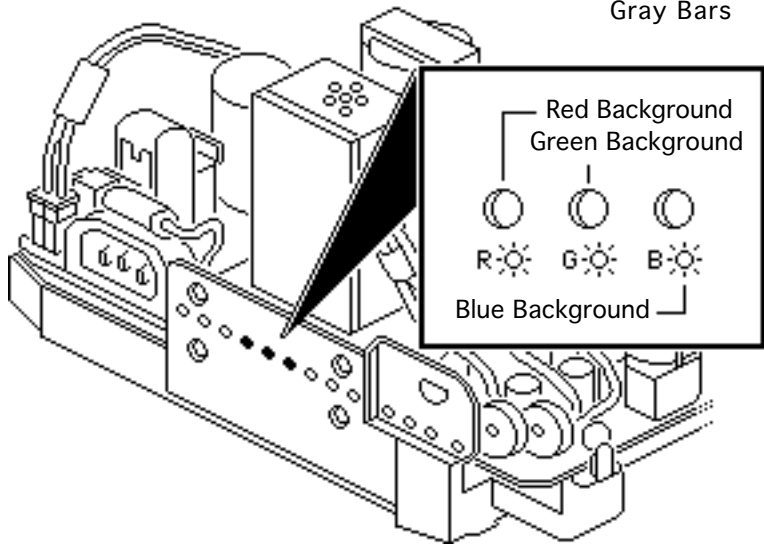

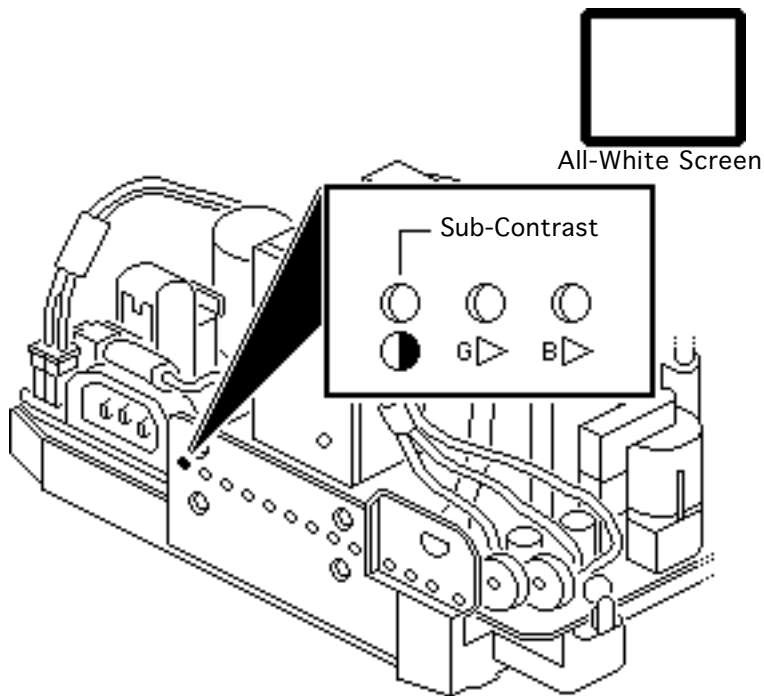

Important: Readings from light meter models R77, L-248, and 246 differ. Please note which meter you are using before making adjustments. (See “Light Meter Setup.”)

- 8 Using Display Service Utility, display the All-White Screen test pattern



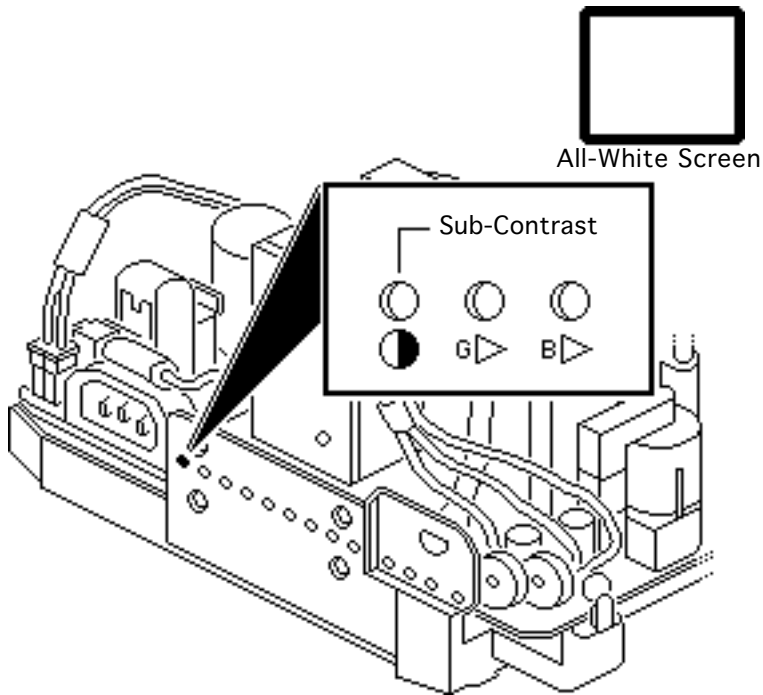

- 9 Using the light meter and a two-inch plastic screwdriver, adjust the sub-contrast control until you get 30 foot lamberts (± 3 foot lamberts), which on the light meter is
- Model R77: 23 on the bottom scale
 - Model L-248: middle of the 10 scale
 - Model 246: 23 on the red scale





Important: Over time, light meter tolerances can vary. If you doubt your meter's accuracy, verify the readings with a known-good light meter or photometer.





Light Meter Setup

This topic covers setup for three light meter models: R77, L-248, and 246. Model R77 (Apple part number 076-0310) is the newest model available.

Model R77

The R77 light meter is capable of reading luminance from 10 to 1,000 footcandles (fc).

Before you begin, remove the 10X multiplier plate



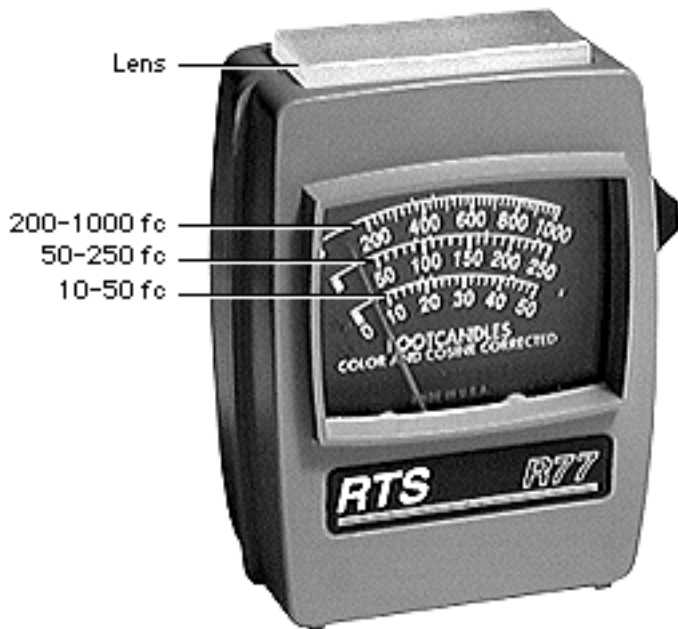

from the lens.

Three scales are shown on the light meter:

- 200-1000 fc
- 50-250 fc
- 10-50 fc

Because display screen luminance typically ranges from 10 to 50 fc, take readings from the bottom scale only.



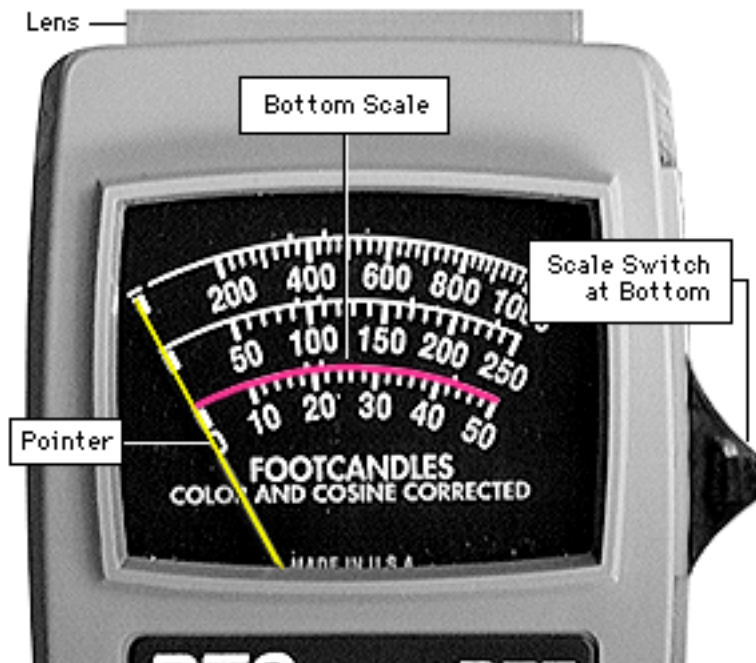

To measure a display screen's luminance,

- 1 Set the scale switch to the bottom position (to set up the 10-50 fc scale).
- 2 Place the lens against the middle of the screen and read the bottom scale.

Note: When the light meter is not in use, slide the scale switch to its top position, and store the meter in its protective case.

Important: If you suspect the light meter is giving false



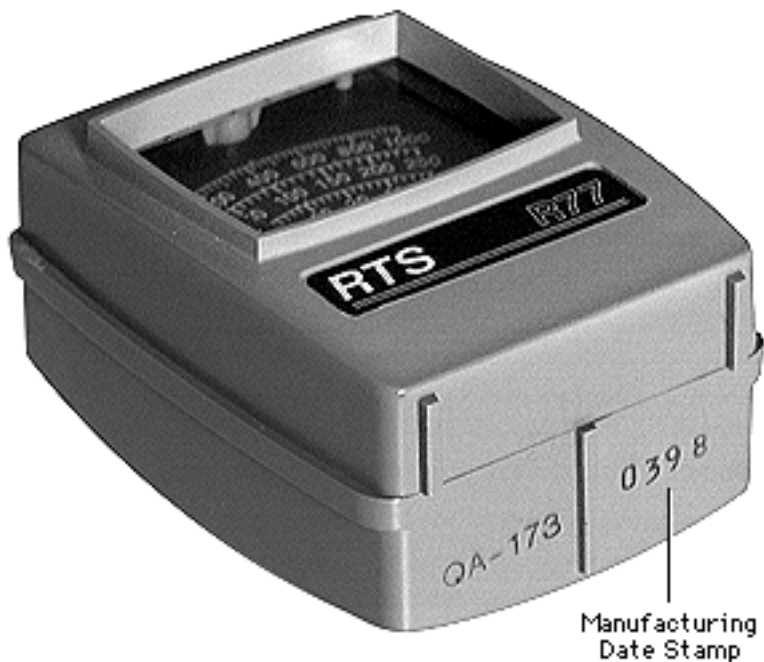

readings, verify the readings with a known-good light meter or photometer. Also check the age of the R77 light meter by its four-digit manufacturing date stamp (such as 0398 for March 1998).

Caution: Dropping the meter can permanently damage its accuracy. A shock-damaged meter might read incorrectly or its pointer may not drop to zero.



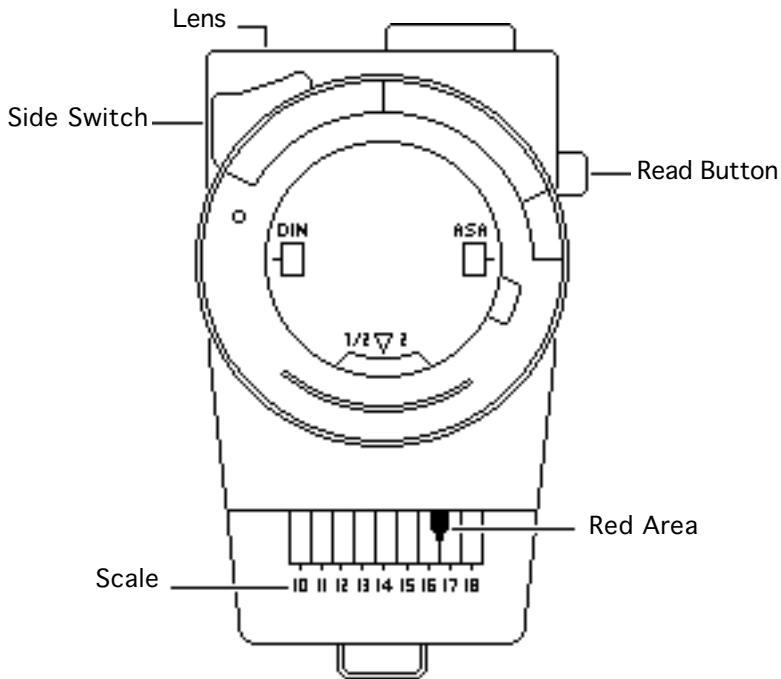

Model L-248

- 1 Press the red button on the back of the light meter. If the reading is out of the red area, replace the battery.
- 2 Move the side switch to its upper position so that the scale reads 10 through 18.
- 3 Uncover the lens of the meter.
- 4 Place the lens against the middle of the screen and press the read button to read the scale.



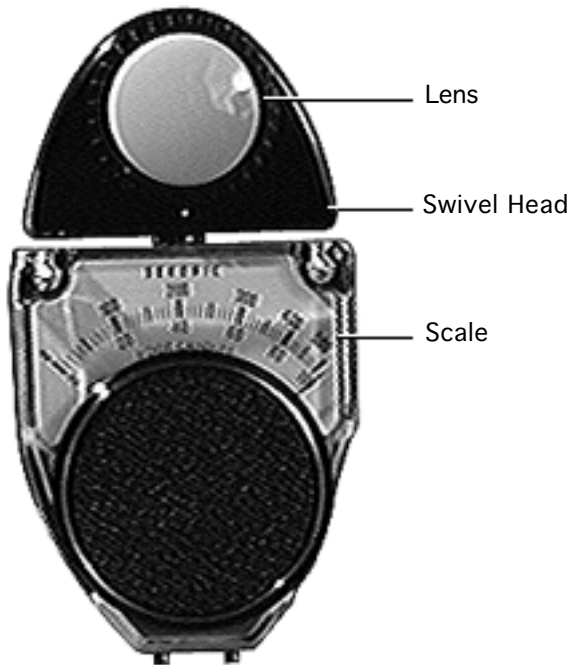

Model 246

- 1 Remove the metal slide, if installed, from the top of the light meter.
- 2 Install the white lens with the red dot.
- 3 Rotate the swivel head so the lens of the meter faces the monitor.
- 4 Place the lens against the middle of the screen and read the scale.





Convergence

Before you begin, remove the rear cover.

⚠ Warning: This product contains high voltage and a high-vacuum picture tube. To prevent serious injury, review CRT safety in Bulletins/Safety.

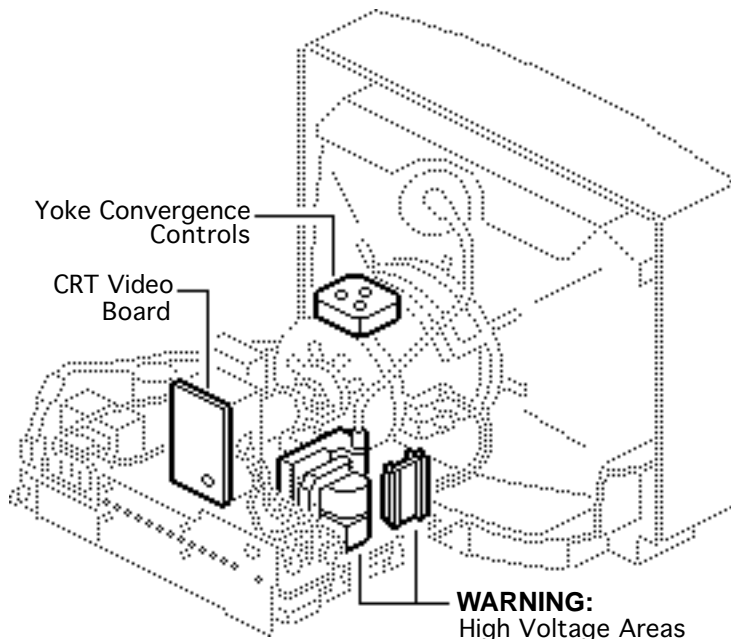

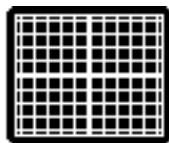

Crosshatch I

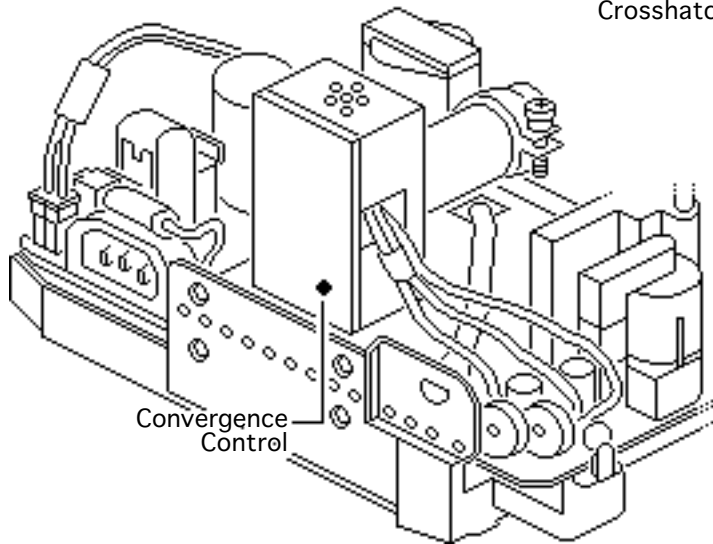

Convergence Control

- 1 Use Display Service Utility to display the Crosshatch I test pattern.
- 2 Using a hex-head plastic adjustment tool, adjust the convergence control on the CRT video board for best overall convergence.



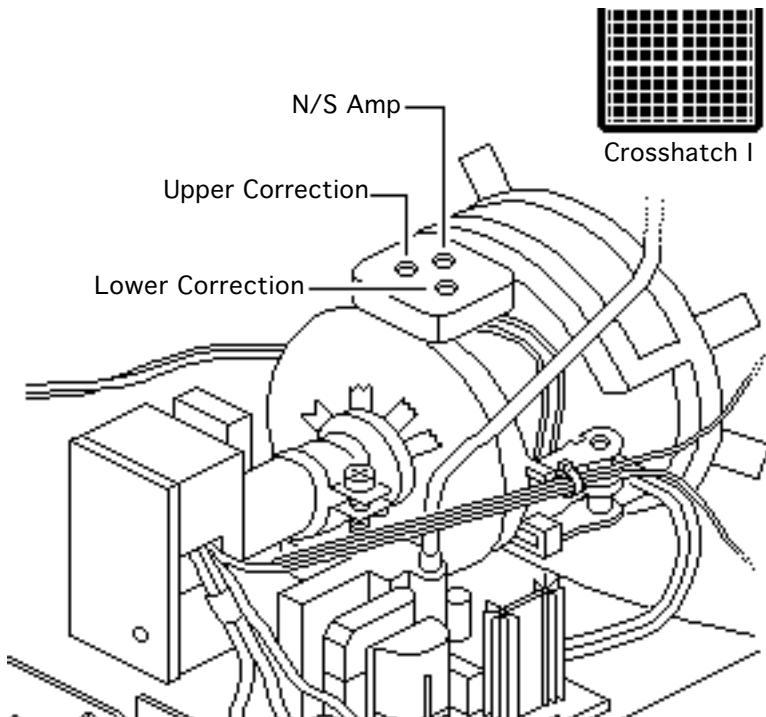

- 3 Using a hex-head plastic adjustment tool, adjust the N/S amp control for best convergence of horizontal lines at the top and bottom of the screen.
- 4 Adjust the lower correction control for best convergence of vertical lines at the bottom of the screen.
- 5 Adjust the upper correction control for best convergence of vertical lines at the top of the screen.





Geometric Distortion

Before you begin, remove the rear cover.

⚠ Warning: This product contains high voltage and a high-vacuum picture tube. To prevent serious injury, review CRT safety in Bulletins/Safety.

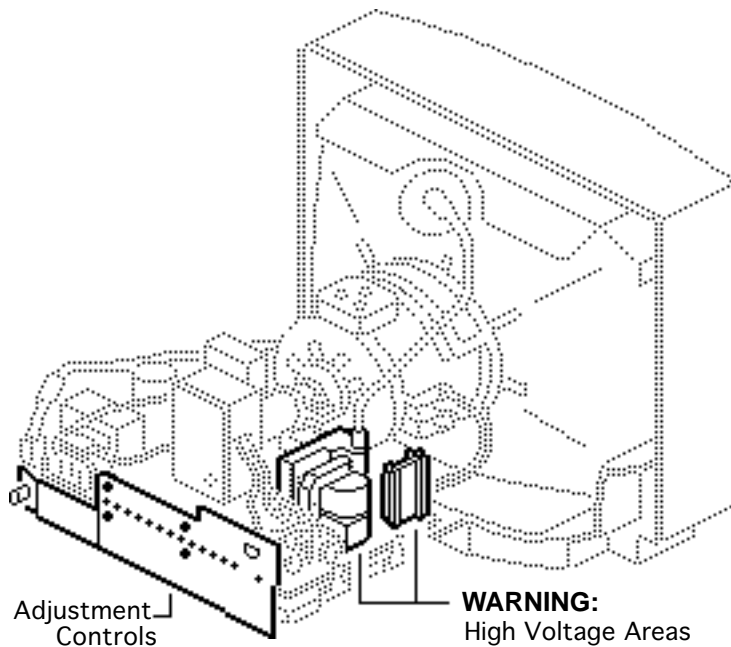



Note: Perform the following geometric adjustments only if your attempts to adjust raster distortions with the external geometry controls do not produce the results you wanted.



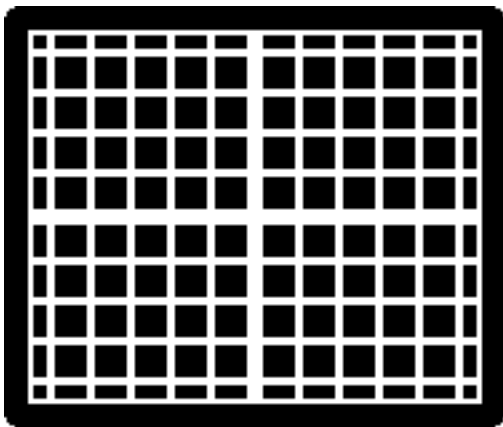

Crosshatch I

- 1 Use Display Service Utility to display the Crosshatch I test pattern.
- 2 Verify that the boxes on the top row are the same size as the boxes on the bottom row, and the boxes on the left side are the same size as the boxes on the right side.



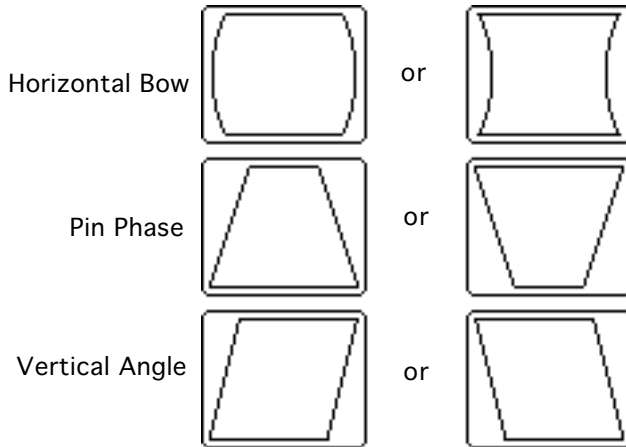

⚠ Warning: The entire yoke assembly has very high voltage. To prevent electrical shock, do not touch the yoke assembly, the anode wire, or the yoke wires.

- 3 To determine which control to adjust, compare the display with the distortions shown.



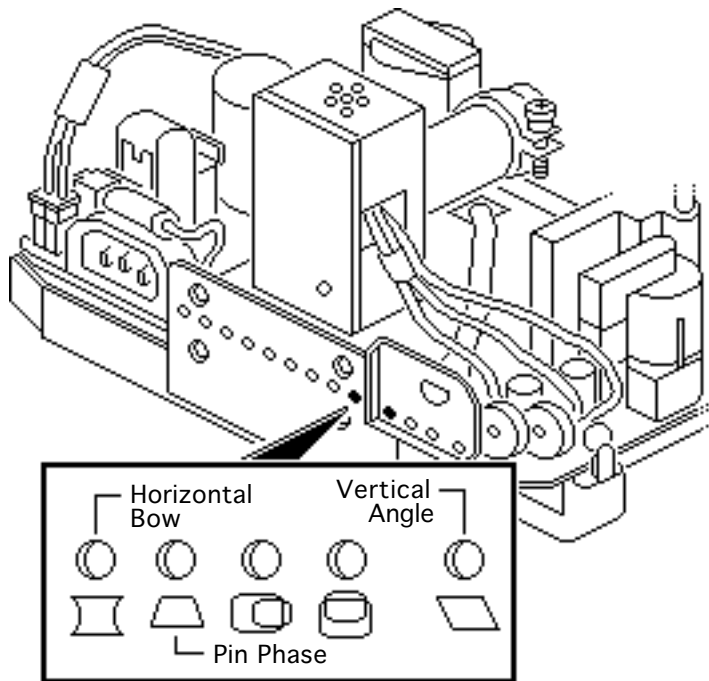

- 4 Using a hex-head plastic adjustment tool, adjust the control that is appropriate for the distortion. (See controls illustration at left.)
- 5 If the display is so distorted that you can't tell which adjustments to make, perform the adjustments in the following sequence:
 - Pin Phase
 - Vertical Angle
 - Horizontal Bow





- 6 If the display is still distorted, repeat the vertical angle and pin phase adjustments.

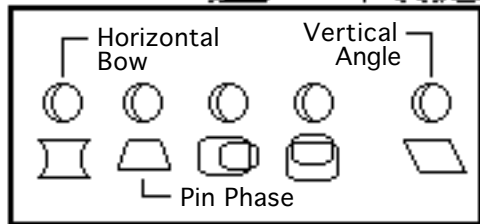
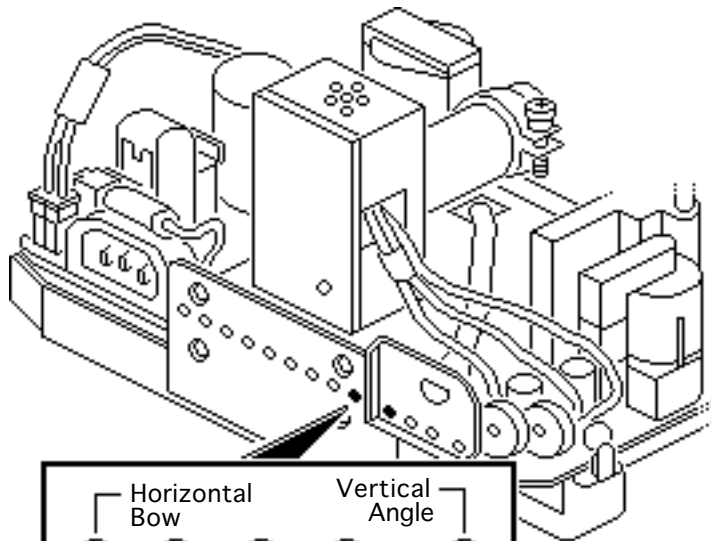

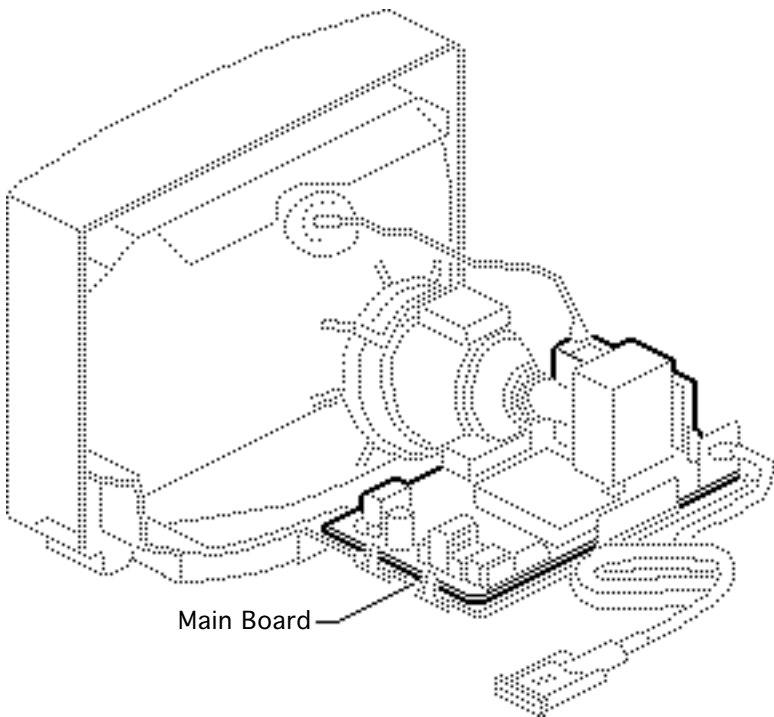

- 7 If you can't correct the distortion, replace the main board. See "Main Board" in the Take Apart chapter.





Exploded View

Apple AudioVision 14 Display



